



INDUSTRIAL TRUCK DIVISION



OPERATORS MANUAL

FOR

CT-20B

O-157

CLARK EQUIPMENT COMPANY

PUBLISHED BY

TECHNICAL SERVICE DEPARTMENT,
BATTLE CREEK, MICHIGAN, U.S.A.

I N S T R U C T I O N S O N U S E O F M A N U A L

This Operator's Manual is published as a service reference guide and includes Specifications, Operating Instructions, Lubrication and Preventive Maintenance Instructions, and Trouble Shooting Guide.

The TABLE OF CONTENTS for this manual is printed on green paper and is placed at the front for easy reference. A separate INDEX (also printed on green paper) is placed in front of the Lubrication and Preventive Maintenance Section.

Lubrication and Preventive Maintenance Instructions are listed under the TIME INTERVALS that they should be performed. The TIME INTERVAL is part of the page number. Such as: 8H 002-0; 8H is the time interval (8 operating hours), 002 is the page number, and -0 is a code number that you as a customer should disregard. The dash number or code number is for the benefit of the publisher only.

It is impossible to cover all types of machine operations in one manual. Operating conditions should determine the lubrication and maintenance intervals. Common sense and a close observance can best determine the frequency with which you should service your machine.

The care you give your machine will greatly determine the satisfaction and service life that you will obtain from it. A definite maintenance program should be set up and followed. Haphazard maintenance will only lead to faulty performance and short life.



INDUSTRIAL DIVISION



THE INDUSTRIAL DIVISION OF THE DEPARTMENT OF COMMERCE
IS AUTHORIZED TO ISSUE INDUSTRIAL PATENTS FOR THE
PROTECTION OF THE RIGHTS OF INVENTORS IN THE
FIELD OF INDUSTRIAL INVENTIONS.

THE INDUSTRIAL DIVISION OF THE DEPARTMENT OF COMMERCE
IS AUTHORIZED TO ISSUE INDUSTRIAL PATENTS FOR THE
PROTECTION OF THE RIGHTS OF INVENTORS IN THE
FIELD OF INDUSTRIAL INVENTIONS.

THE INDUSTRIAL DIVISION OF THE DEPARTMENT OF COMMERCE
IS AUTHORIZED TO ISSUE INDUSTRIAL PATENTS FOR THE
PROTECTION OF THE RIGHTS OF INVENTORS IN THE
FIELD OF INDUSTRIAL INVENTIONS.

THE INDUSTRIAL DIVISION OF THE DEPARTMENT OF COMMERCE
IS AUTHORIZED TO ISSUE INDUSTRIAL PATENTS FOR THE
PROTECTION OF THE RIGHTS OF INVENTORS IN THE
FIELD OF INDUSTRIAL INVENTIONS.

THE INDUSTRIAL DIVISION OF THE DEPARTMENT OF COMMERCE
IS AUTHORIZED TO ISSUE INDUSTRIAL PATENTS FOR THE
PROTECTION OF THE RIGHTS OF INVENTORS IN THE
FIELD OF INDUSTRIAL INVENTIONS.



INDUSTRIAL TRUCK DIVISION



TABLE OF CONTENTS

<u>Page</u>	<u>Description</u>
A001	Instructions On Use Of Manual
A003	Table Of Contents
B001	Illustration Of Machine
B003	Specifications
B004	Specifications
B005	Specifications
B031	New Machine 50 Hour Inspection

O P E R A T I O N S

C002	Overall Controls
C003	Instrument Indicators
C003	Starting and Operating Instructions
C103	Safety and Operating Suggestions

L U B R I C A T I O N A N D P R E V E N T I V E M A I N T E N A N C E

<u>Time Interval (H=Hours)</u>	<u>Page Number (0000-)</u>	<u>Description</u>
H	001	Index
8H	000	<u>8 Hour Lubrication & Preventive Maintenance Illustration</u>
8H	001	Lights, Horn, Fuel Tank and Circuit Breaker.
8H	003	Crankcase Oil Level check; Recommended Lubricants
8H	103	Cooling System check
8H	203	Instrument Indicators, check
8H	303	Brake Pedal Free Travel check; Parking Brake Operation check
8H	403	Engine Air Cleaner service
8H	603	Tires inspect
100H	000	<u>100 Hour Lubrication & Preventive Maintenance Illustration</u>
100H	001	Converter Transmission Level check; Fuel Tank and Lines inspect
100H	003	Engine Crankcase drain & refill; Crankcase Ventilation inspect; Engine Oil Filter change
100H	103	Cooling System inspect; clean radiator fins
100H	203	Fan and Alternator Belt adjustment
100H	302	Brake Pedal Free Travel check
100H	303	Brake Pedal Free Travel adjust; Master Cylinder level check
100H	602	Alternator - Battery - Electrical System - CAUTION: LUBRICATE MACHINE; Visual Inspection of Vehicle.
100H	603	Steering Gear verify lubricant level; Battery inspect
100H	702	Lubrication Diagram
100H	703	Lubrication Chart
500H	000	<u>500 Hour Lubrication & Preventive Maintenance Illustration</u>
500H	001	Fuel Pump Strainer clean; Fuel Pump Operation check
500H	003	Converter Transmission, drain & refill
500H	202	Steering Gear adjust
500H	303	Steering Axle and Linkage adjust, Suspension - inspect
500H	403	Manifolds check security of mounting; Nuts, Bolts and Cap Screws security check
1000H	000	<u>1000 Hour Lubrication & Preventive Maintenance Illustration</u>
1000H	001	Engine Tune Up; Air Cleaner, Fuel Pump
1000H	003	Engine Tune Up; Cylinder Head Stud Nuts Intake and Exhaust Manifolds, Crankcase Ventilation; Intake and Exhaust Valve Clearance adjustments
1000H	004	Engine Tune Up; Intake and Exhaust Valve Clearance adjustments
1000H	103	Engine Tune Up; Compression test, Spark Plugs
1000H	203	Engine Tune Up; Distributor
1000H	204	Engine Tune Up; Tach Dwell Meter
1000H	303	Engine Tune Up; Contact Point Adjustment; Ignition Timing
1000H	403	Engine Tune Up; Vacuum Test and Carburetor adjustment
1000H	503	Engine Tune Up; Governor Adjustment
1000H	603	Starting Motor inspect



INDUSTRIAL TRUCK DIVISION



TABLE OF CONTENTS

LUBRICATION AND PREVENTIVE MAINTENANCE

<u>Time Interval (H=Hours)</u>	<u>&</u>	<u>Page Number (0000-)</u>	<u>Description</u>
1000H		713	Alternator inspect
1000H		803	Wheel Bearings clean and repack; adjust
1000H		805	Axle Ends clean and repack
1000H		912	Bleeding Brake System
1000H		1003	Brake adjustment
1000H		1103	Hand Brake adjustment
1000H		1202	Cooling System inspect and clean
1000H		1303	Drop Gear Case and Differential - drain and refill
1000H		1703	Transmission Pressure checks
1000H		1793	Neutral Starting Switch, adjustment check
1000H		1794	Road Test and Performance check

TROUBLE SHOOTING GUIDE

<u>Page</u>	<u>Description</u>
TS 001	Engine
TS 251	Fuel System
TS 321	Cooling System
TS 341	Ignition System
TS 361	Starter
TS 391	Alternator
TS 401	Battery & Horn
TS 427	Transmission
TS 481	Drive Axle
TS 521	Steering Axle
TS 541	Brake System
TS 561	Steering

CLARK
EQUIPMENT

INDUSTRIAL TRUCK DIVISION

CLARK
EQUIPMENT

TOWING TRACTOR

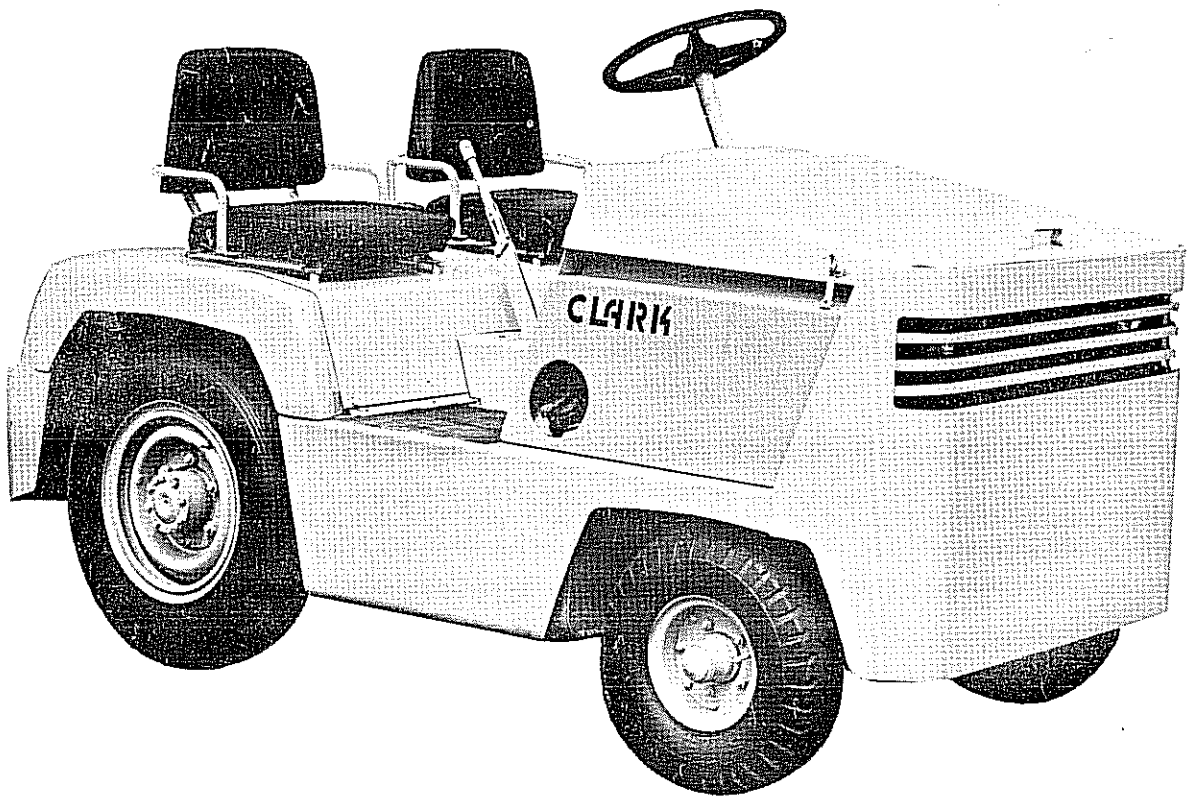
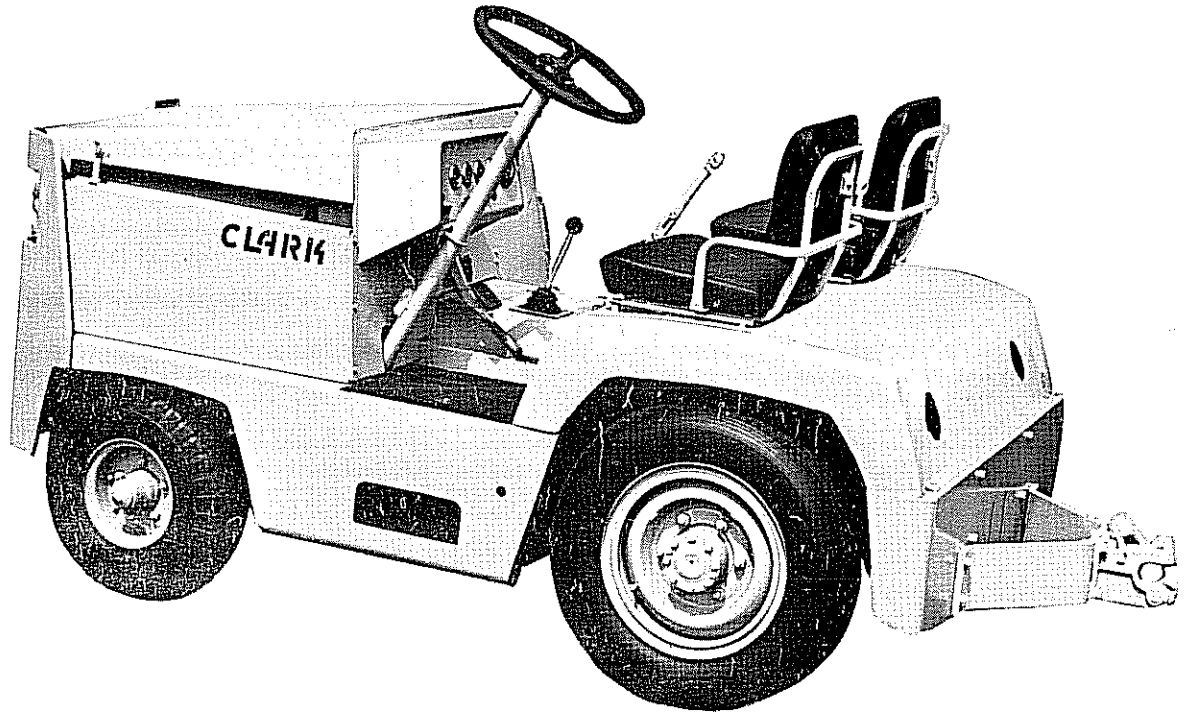

Plate 7738. Illustration of Machine



INDUSTRIAL TRUCK DIVISION



SPECIFICATIONS

GENERAL

Type of vehicle Towing Tractor

ENGINE

Type "L" Head
 Bore and Stroke 3.4375 x 4.375
 Number of cylinders 6
 Maximum brake horsepower..... 85 at 2600 R.P.M.
 Maximum torque, lbs., ft. ... 196 at 1200 R.P.M.
 Displacement 244 cubic inches
 Firing Order 1-3-5-6-4-2
 Oil Capacity 5.5 quarts

Lubrication system Submerged gear type oil
 pump supplies oil pressure
 to all main, connecting rod
 and camshaft bearings, tappets
 and timing gears.

GOVERNOR setting (no load)..... 2600 R.P.M.

FUEL TANK capacity 17 gals.

COOLING SYSTEM capacity 10.5 quarts

FAN BELT deflection 3/4 to 1 inch

Split Rim Wheels...torque wheel nuts to 240 lbs.
 "Dry Thread"

ELECTRICAL SYSTEM..... 12 volt negative ground

BATTERY 12 volt

Starting Motor

Brush spring tension 35 ounces

TRANSMISSION AND CONVERTOR

Reverse 6.5
 First 5.3
 Second 8.6
 Third 12.7
 Speeds 3 Speed
 Mounting Torque Converter Housing
 Capacity (including convertor) 10 Qts.

CONVERTOR STALL RATIO 2.06:1

FRONT AXLE

Axle alignment

Toe-in 0 degrees

Camber angle 1 degree

Caster 0 degrees

Left-hand turning radius angle;

left wheel 55 degrees

right wheel 38 degrees

Right-hand turning radius angle;

left wheel 38 degrees

right wheel 55 degrees

REAR AXLE

Ratio 17.311 to 1

Capacity 10 quarts

WHEELS AND TIRES

(Drive) Rear 6.50x16-6 Ply

(Steer) Front 6.00x 9-6 Ply

Air Pressures

Front 40 pounds

Rear..... 40 pounds

SPECIFICATIONS

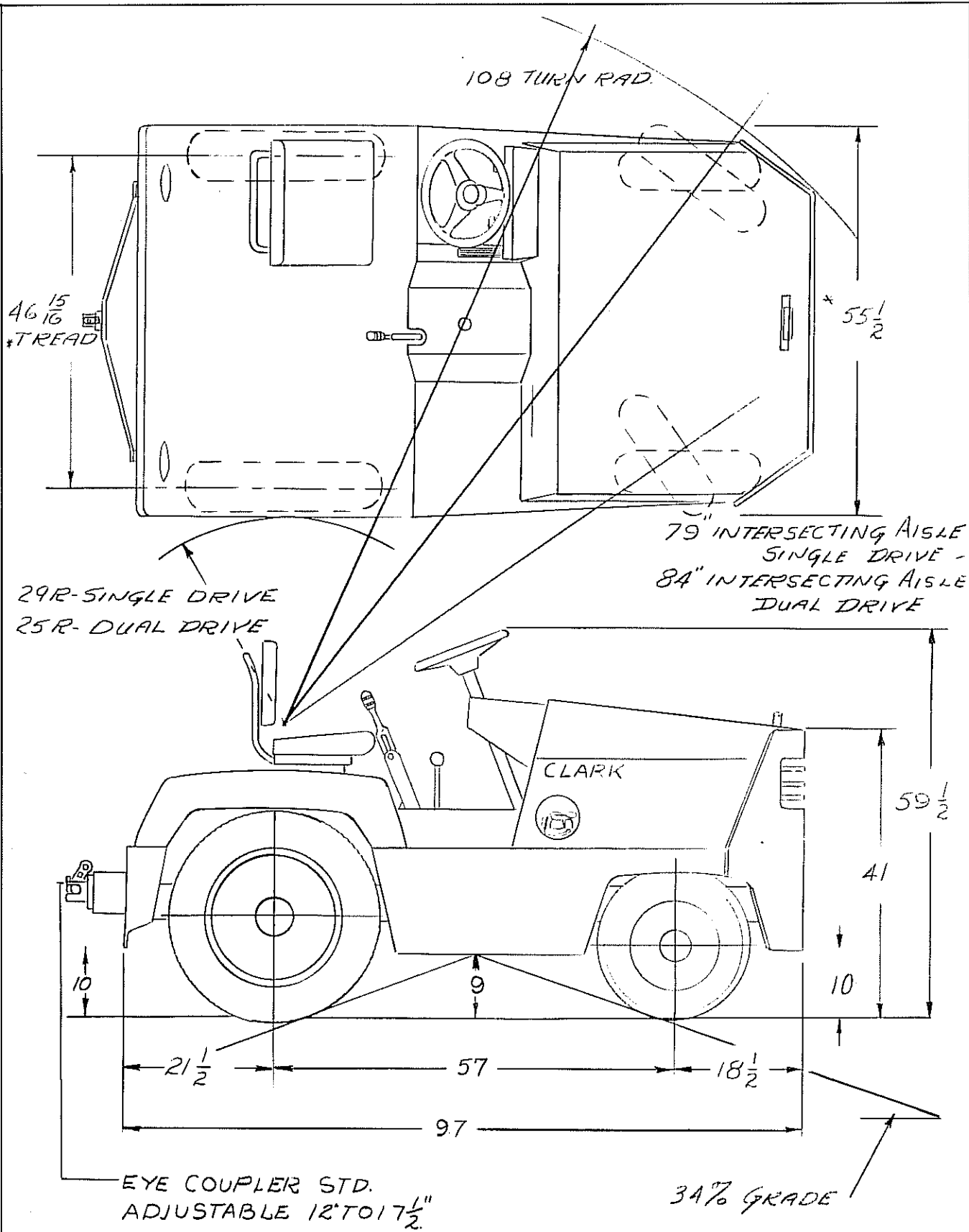



INDUSTRIAL TRUCK DIVISION



SPECIFICATIONS

TORQUE SPECIFICATIONS

Engines have many studs, bolts, and cap screws of special material and sizes and it is very important that special care be exercised to torque all studs and bolts correctly.

The torque specifications, foot pounds, listed below, MUST be followed in order to have the engine conform to the original specifications.

Size-Diameter	5/16"	3/8"	7/16"	1/2"	9/16"	5/8"
Cylinder Heads	-----	35-40	70-85	100-110	130-140	145-155
Manifolds	15-20	25-30	40-50	50-60	50-60	60-70
Gear Covers, Water Pumps, Front and Rear End Plates	15-20	25-30	50-55	80-90	-----	-----
Oil Pans	12-16	12-16	-----	-----	-----	-----



INDUSTRIAL TRUCK DIVISION



NEW MACHINE 50 HOUR SERVICE AND INSPECTION

Air Cleaner, Service	8H 403
Battery Test and Level Check	100H 603
Brake Master Cylinder Level Check	100H 303
Brake Pedal, Adjust	100H 302
Cooling System, Inspect	100H 103
Cylinder Head, Tighten	1000H 003
Engine Crankcase, Drain and Refill	100H 003
Engine Oil Filter, Change	100H 003
Fan Belt, Adjust	100H 203
Fuel Pump Strainer, Clean or Replace	500H 001
Hand Brake, Adjust	1000H 1103
Intake and Exhaust Manifold, Tighten	500H 403
Lubricate Machine	100H 703
Nuts, Bolts and Capscrews, Tighten	500H 403
Steering Gear Level Check	100H 603
Transmission and Converter Level Check	100H 001

NOTE

PERFORM THIS SERVICE AND INSPECTION AFTER
THE FIRST 50 HOURS OF OPERATION ON NEW
MACHINES.

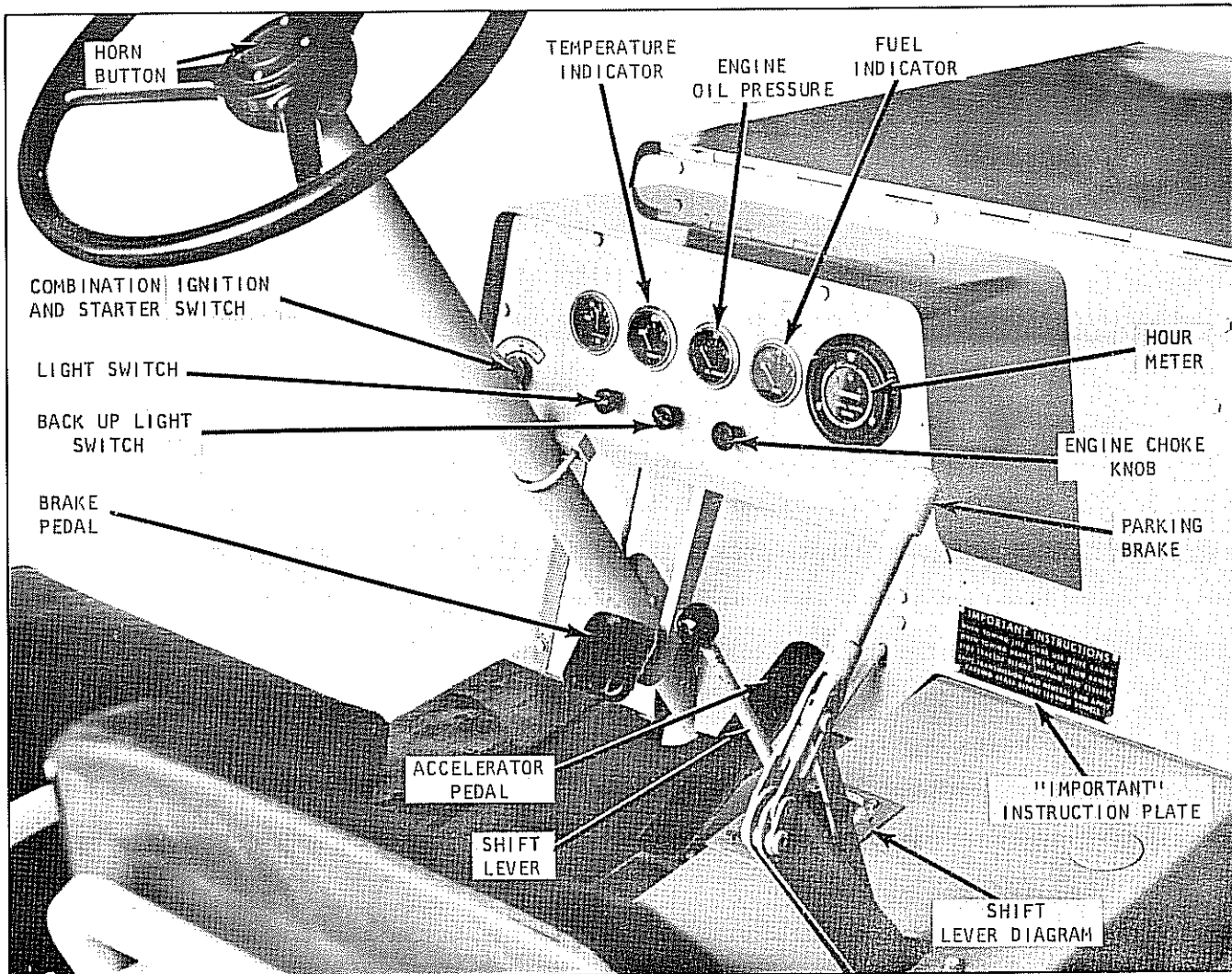

Plate 7712. Location of Controls

PURPOSE AND USE OF OPERATING CONTROLS

SHIFT LEVER. It is used to direct the tractor transmission which supplies the vehicle with two forward speeds and one reverse. A shifting diagram aids the operator in selecting correct gear.

HAND BRAKE. The hand brake, which is connected to the transmission drive shaft, is used for securing machine on a reasonable grade and parking.

INSTRUMENT PANEL. The panel contains the following engine instruments: Ammeter, oil pressure, water temperature, fuel indicator, light switch, choke button and combination ignition and starter switch.

TO START ENGINE

With accelerator 1/3 open, pull out on choke button. Place shift lever in neutral position. Turn ignition switch to start position and engine will start. Starter should not be engaged longer than 15 second periods at a time. If the engine does not start at first attempt, allow 10 to 15 seconds time to elapse, then repeat. If the engine becomes over-choked or flooded, depress the accelerator pedal to full depressed position and engage the starter. After the the engine starts, let up on the accelerator pedal to obtain desired engine speed, and watch oil pressure indicator. If oil pressure does not build up immediately stop the engine and investigate the cause.

OPERATIONS

CAUTION

DO NOT RUN ENGINE FOR LONG PERIODS AT IDLE SPEEDS, AS IT IS NOT ONLY DETRIMENTAL TO THE ENGINE BUT ALSO INCREASES OPERATING COSTS AS YOU ARE WASTING FUEL WITHOUT BENEFIT.

TO OPERATE TOW TRACTOR: When the vehicle is to be placed into motion, depress the brake pedal and release the hand brake. Release pressure on the accelerator pedal, allowing the engine to idle. Select the proper driving range to start the intended load.

Release the pressure on the brake pedal and slowly depress the accelerator pedal to place the vehicle in motion. Particular attention should be given to the following regarding the use of the automatic transmission.

The vehicle must be brought to a complete stop before placing the shift

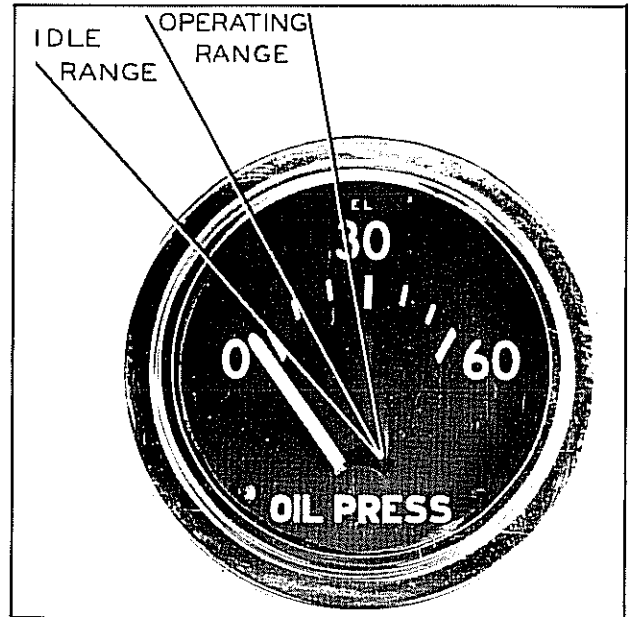

Plate 6417. Oil Pressure Indicator

lever into the R or reverse position. To rock the vehicle back and forth, maintain a steady but moderate pressure on the accelerator pedal and move the shift lever back and forth between the R and D positions.

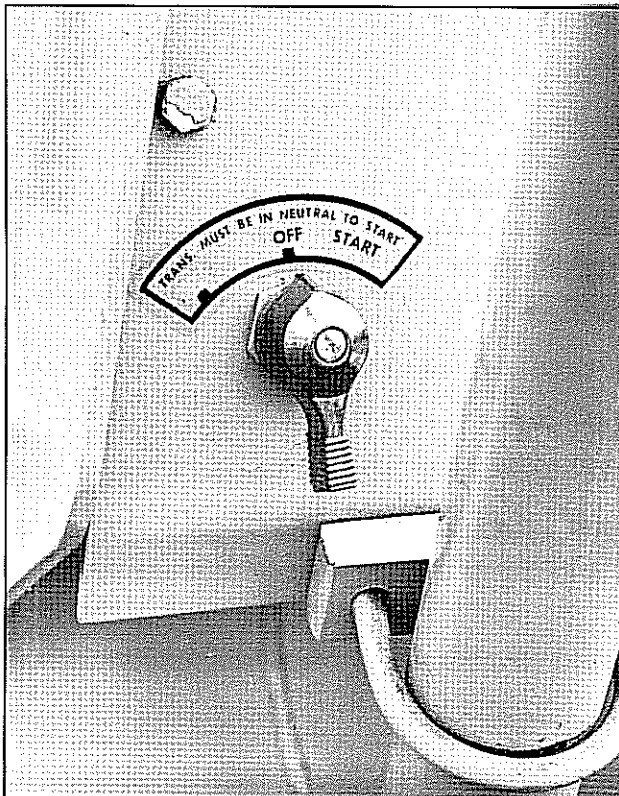
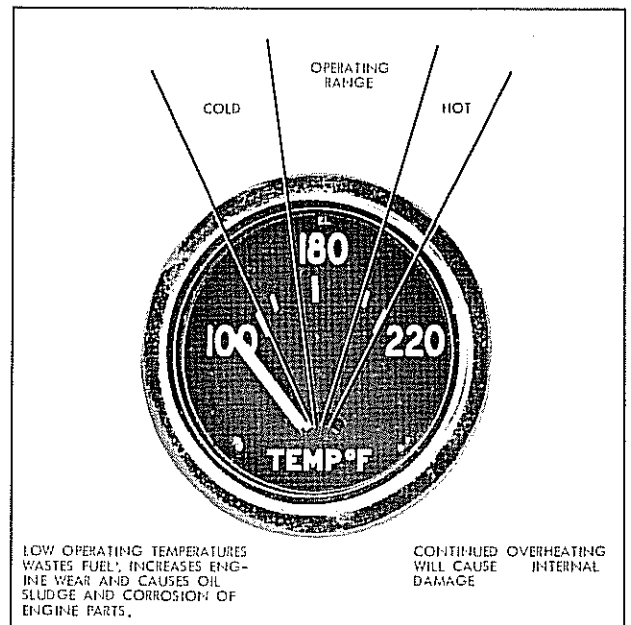

Plate 7714. Ignition/Starter Switch



LOW OPERATING TEMPERATURES WASTE FUEL, INCREASES ENGINE WEAR AND CAUSES OIL SLUDGE AND CORROSION OF ENGINE PARTS.

CONTINUED OVERHEATING WILL CAUSE INTERNAL DAMAGE

Plate 6287. Temperature Indicator



INDUSTRIAL TRUCK DIVISION



OPERATIONS

TO OPERATE ACCESSORIES

LIGHTS. The lights are operated by a switch located on the instrument panel. The switch operates the head lights and tail lights.

TO STOP VEHICLE

1. Remove foot from accelerator pedal.
2. Depress foot brake pedal.
3. As vehicle comes to a halt, place gear shift lever into neutral position.
4. If vehicle is to be parked, turn ignition switch to "OFF" position and apply hand brake.

SAFETY PRECAUTIONS

1. Only qualified drivers should be allowed to operate the vehicle.
2. Do not tow a train of more than three trailers.
3. Drive slowly in rough or congested areas.
4. Do not drive with wet or greasy hands.
5. Observe the Operating Rules and Preventive Maintenance Instructions A.S.A. B56.1 Safety Code for Powered Industrial Trucks.

NOTE

1,000 POUND TRACTOR DRAWBAR PULL WILL
EQUAL A 10,000 POUND LOAD ON A FOUR
WHEEL TRAILER (INCLUDING WEIGHT OF TRAILER.)

IMPORTANT — Since the Alternator and regulator are designed for use on only one polarity system, the following precautions must be observed when working on the charging circuit. Failure to observe these precautions will result in serious damage to the electrical equipment.

1. When installing a battery, always make absolutely sure the ground polarity of the alternator and the ground polarity of the battery are the same.

2. When connecting a booster battery, make certain to connect the negative battery terminals together and the positive battery terminals together.

3. When connecting a charger to the battery, connect the charger positive lead to the battery positive terminal and the charger negative lead to the battery negative terminal.

4. Never operate the alternator on open circuit. Make absolutely certain all connections in the circuit are secure.

5. Do not short across or ground any of the terminals on the alternator or regulator.

6. Do not attempt to polarize the alternator.



INDUSTRIAL TRUCK DIVISION



LUBRICATION AND PREVENTIVE MAINTENANCE INDEX

(8 HOURS)	Time Interval (H=Hours)	&	Page Number (0000-)	(100 HOURS cont'd)	Time Interval (H=Hours)	&	Page Number (0000-)
Air Cleaner Service.....	8H		403	Wiring, inspect.....	100H		602
Brake Pedal Operation	8H		303	(500 HOURS)			
Brake Operation, Parking....	8H		303	Fuel Pump	500H		001
Crankcase Oil Level check...	8H		003	Fuel Pump Strainer	500H		001
Engine Cooling System check.	8H		103	Intake and Exhaust Manifold	500H		403
Fuel Tank check	8H		001	Nuts, Bolts & Capscrews tighten	500H		403
Horn	8H		001	Steering Axle & Linkage adjustment	500H		303
Instrument Panel Indicators.	8H		203	Steering Gear adjustment..	500H		202
Ignition System Circuit Breaker	8H		001	Transmission & Converter drain & refill	500H		003
Lights	8H		001	(1000 HOURS)			
Tires Inflation check	8H		001	Alternator	1000H		713
Tires Inspect	8H		603	Axle Ends clean and repack	1000H		805
Tires split rim - CAUTION...	8H		604	Brake System; test, adjust and bleed	1000H		912
(100 HOURS)				Carburetor, adjust	1000H		403
Battery Level and test ...	100H		603	Compression test, Engine	1000H		103
NOTE				Cooling System, Inspect and clean	1000H		1202
Alternator - Battery - Electrical System CAUTION	100H		602	Crankcase Ventilation ...	1000H		003
Brake Master Cyl. Level check	100H		303	Cylinder Head Tightening Sequence	1000H		003
Brake Pedal, adjust.....	100H		302	Differential, drain and refill.....	1000H		1303
Cooling System	100H		103	Distributor, inspect and adjust	1000H		203
Engine Breather.....	100H		003	Drop Gear case, drain and refill	1000H		1303
Engine Crankcase	100H		003	Engine Tune Up	1000H		001
Engine Oil Filter	100H		003	Governor, adjust	1000H		503
Fan Belt, adjust	100H		203	Hand Brake, adjust	1000H		1103
Fuel Tank and Lines	100H		001				
Lubrication Diagram	100H		702				
Lubrication Chart	100H		703				
Steer Gear Level check....	100H		603				
Transmission & Converter Level check	100H		001				



INDUSTRIAL TRUCK DIVISION



LUBRICATION AND PREVENTIVE MAINTENANCE INDEX

(8 HOURS)	Time Interval (H=Hours)	Page Number (0000-)	(100 HOURS CONT'D)	Time Interval (H=Hours)	Page Number (0000-)
Air Cleaner Service	8H	403	Lift Brackets, inspect	100H	403
Brake Pedal Operation	8H	303	Lift Chain, adjust	100H	403
Brake Operation, Parking... ..	8H	303	Lubrication Chart	100H	703
Clutch Pedal Free Travel, check	8H	605	Steer Gear level check	100H	603
Clutch Release Bearing lubricate	8H	605	Transmission & axle adaptor level check	100H	002
Crankcase Oil Level check..	8H	003	(500 HOURS)		
Engine Cooling System check	8H	103	Fuel Pump	500H	002
Engine Coolant Temp. Indicator.....	8H	203	Fuel Pump Strainer.....	500H	002
Fuel Tank check	8H	002	Hydraulic Oil Filter change..	500H	103
Horn	8H	002	Hydraulic Sump Tank drain & refill.....	500H	103
Horn Fuse	8H	002	Intake and Exhaust Manifold..	500H	403
Hydraulic Control Levers:..	8H	503	Nuts, Bolts & Capscrews, tighten	500H	403
Hydraulic Sump Tank level check	8H	503	Steering Axle & Linkage adjustment	500H	302
Ignition Fuse.....	8H	002	Steering Gear adjustment....	500H	202
Oil Pressure Indicator.....	8H	203	(1000 HOURS)		
Power Steering Pump level check	8H	703	Axle Ends clean and repack..	1000H	805
Tires inspect	8H	603	Brake System; test, adjust & bleed	1000H	912
(100 HOURS)			Carburetor, adjust	1000H	403
Battery Level and Test... ..	100H	603	Compression test, Engine....	1000H	103
Brake Master Cylinder level check	100H	303	Cooling System, inspect & clean	1000H	1202
Brake Pedal, adjust	100H	302	Crankcase Ventilation.....	1000H	003
Clutch, adjust.....	100H	653	Cylinder Head Tightening Sequence	1000H	003
Cooling System	100H	103	Distributor, inspect & adjust.....	1000H	203
Engine Breather.....	100H	003	Engine Tune-Up	1000H	002
Engine Crankcase	100H	003	Generator, inspect.....	1000H	703
Engine Oil Filter.....	100H	003	Governor, adjust.....	1000H	503
Fan Belt, adjust	100H	203	Hand Brake, adjust	1000H	1103
Fuel Tank and Lines.....	100H	002	Ignition Timing	1000H	303
Hydraulic Sump Tank Breather.....	100H	503			
Hydraulic System, inspect	100H	403			

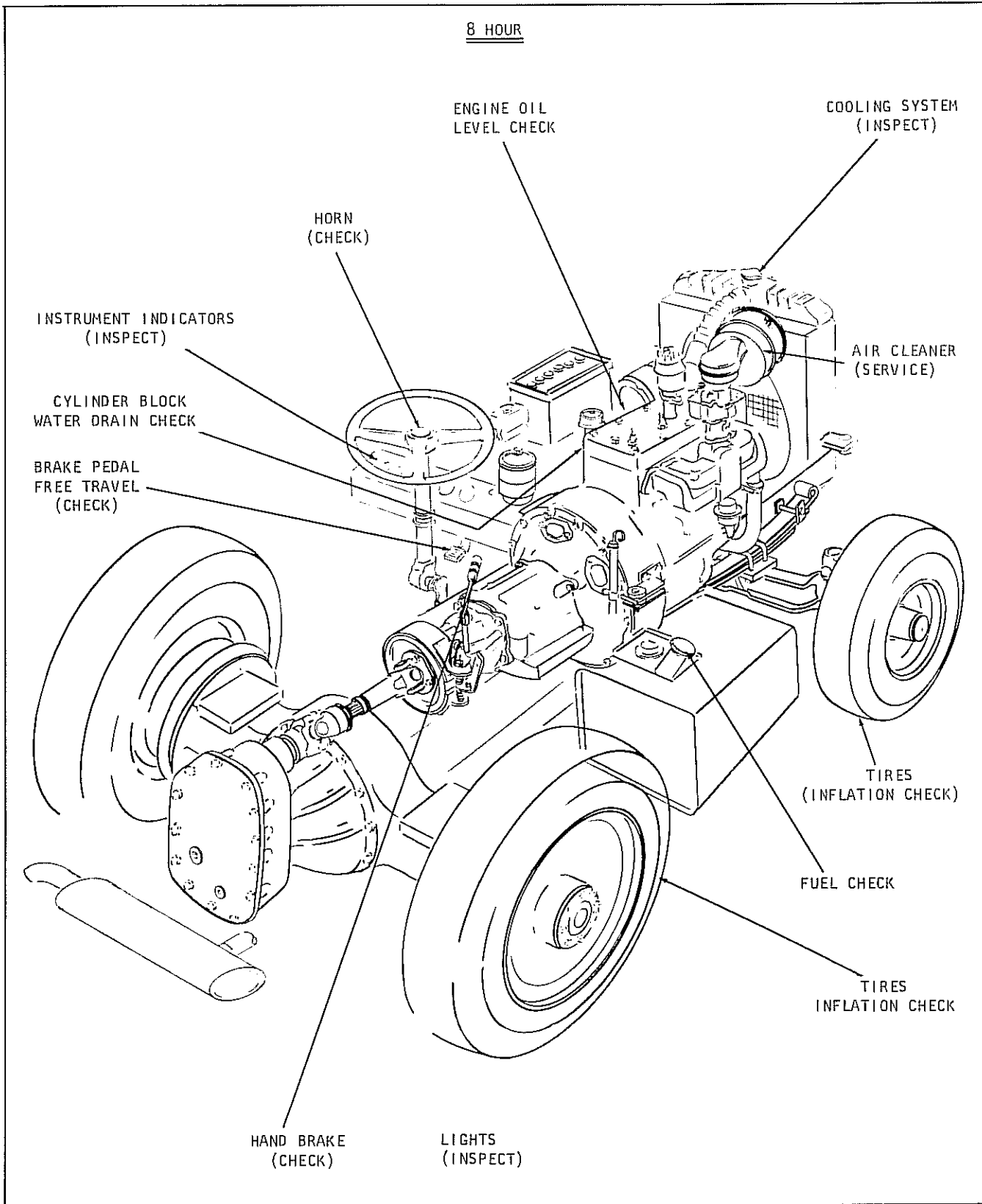

Plate 7733. Lubrication and Preventive Maintenance Illustration

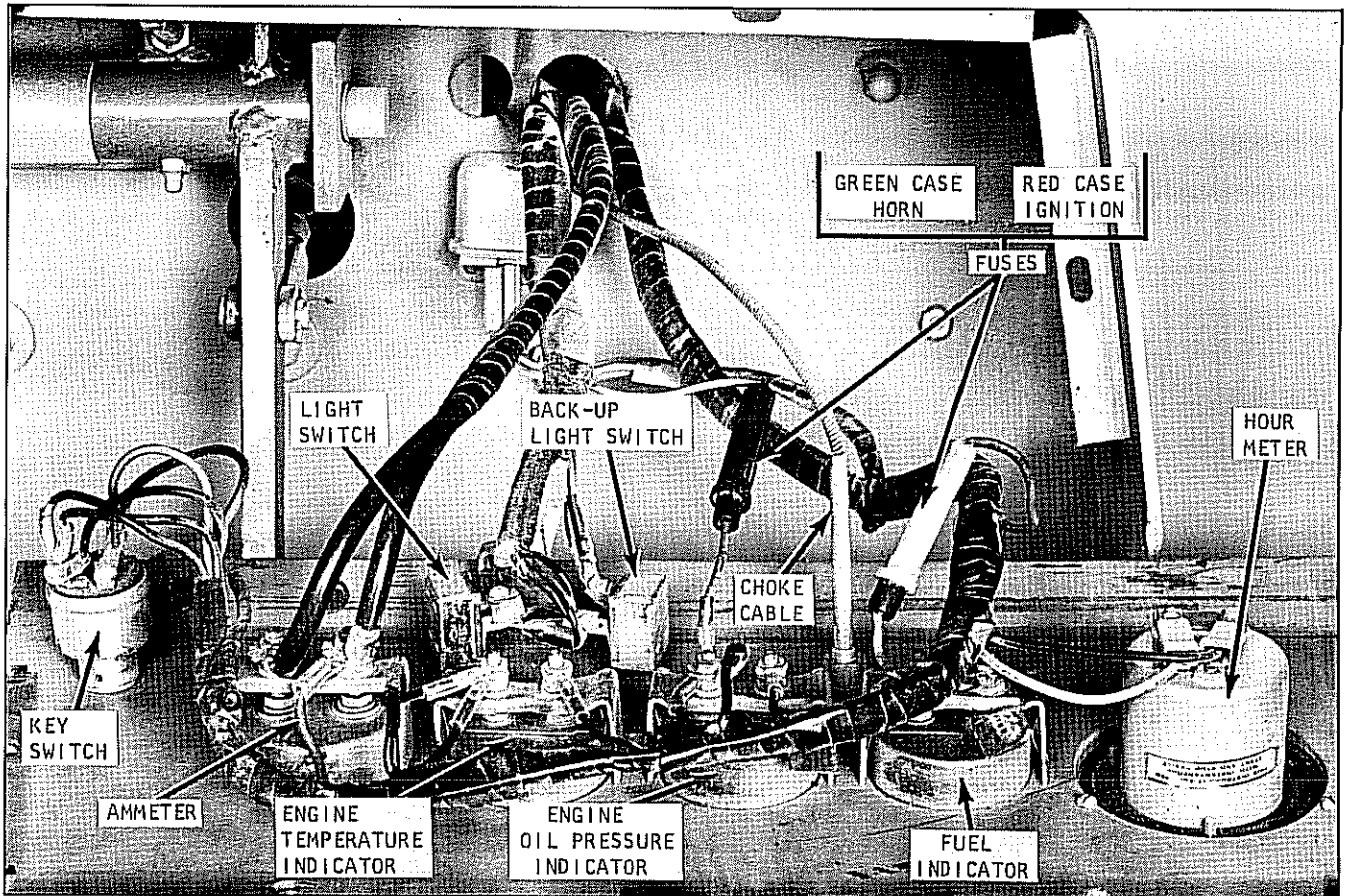

Plate 7713. Electrical System Fuses

HORN

Check to be sure the horn is working properly.

FUEL TANK

Check fuel supply and fill if necessary. Use a good grade of fuel.

LIGHTS

Check head lights and tail lights to be sure they are working properly.

Check tires for proper inflation.

Front 40 lbs.

Rear 40 lbs.

ENGINE CRANKCASE

Before attempting to start the engine, first make sure that it has sufficient oil. The oil filler pipe is located on the right side of the machine. The oil level stick is of the dipstick or bayonet type and is also located on the right side of the machine. Fill the crankcase reservoir through the filler pipe to the proper level as indicated on the dipstick.

CAUTION

NEVER PERMIT THE OIL LEVEL TO FALL BELOW THE "ADD" MARK ON THE DIPSTICK. DO NOT OVERFILL THE CRANKCASE, AS TOO MUCH OIL WILL BRING THE LEVEL HIGH ENOUGH FOR THE CONNECTING RODS TO DIP, THUS CAUSING EXCESSIVE QUANTITIES OF OIL TO BE THROWN TO THE CYLINDER WALLS RESULTING IN OIL CONSUMPTION, SMOKING, EXCESSIVE CARBON DEPOSITS AND FOULED SPARK PLUGS.

NOTE

ON L.P. GAS MACHINES, USE A NON-DETERGENT OIL DURING BREAK-IN PERIODS.

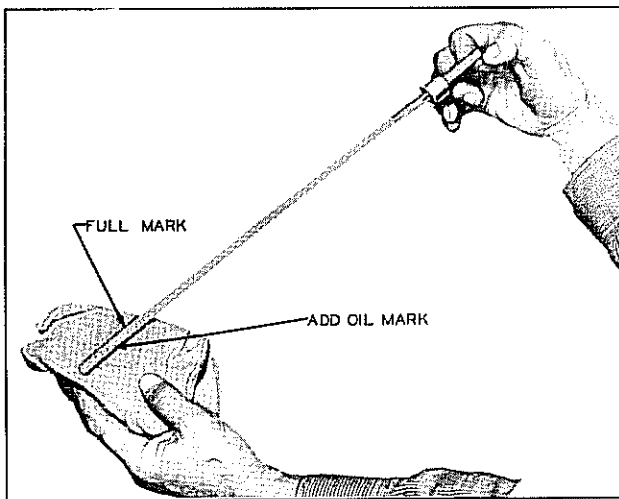

Plate 3145. Crankcase Oil Check

Crankcase Capacity — Refer to Specifications

S.A.E. 10W	0°	to	32° F.
S.A.E. 20W	32°	to	75° F.
S.A.E. 30	above		75° F.

or use 10W — 30 MULTI-GRADE OIL

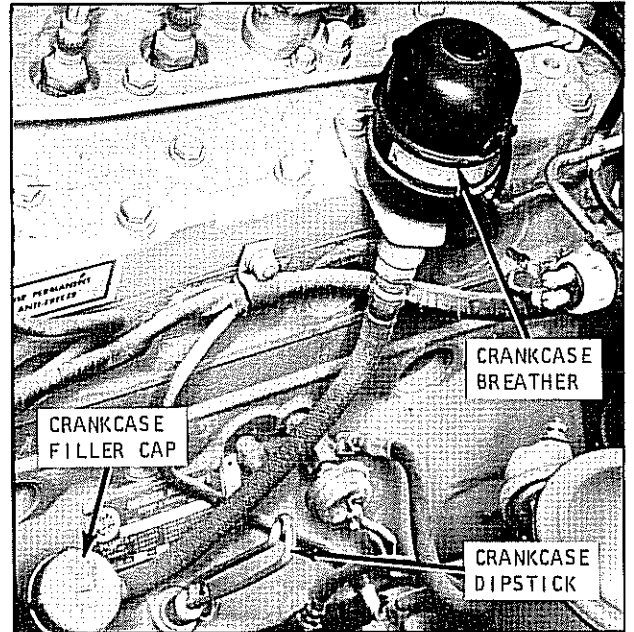

Plate 7715. Engine Crankcase Fill

THIS ENGINE IS EQUIPPED WITH POSITIVE CRANKCASE VENTILATION.

SERVICE INSTRUCTIONS:

1. Air inlet cleaner to the crankcase must be serviced each time carburetor air cleaner is serviced.
2. All connections at air cleaner and the piping between engine and intake manifold must be tight.
3. Ventilation valve must be disassembled every 250 hours or more often, as service dictates, and cleaned thoroughly.
4. Failure to service properly will result in dirt entering engine and will void the warranty.

LUBRICATION AND PREVENTIVE MAINTENANCE

ENGINE COOLING

Make sure that the radiator drain cock and the water drain in the cylinder block are closed Plate 7008. Check radiator coolant level and fill to within 1 inch of the top with clean water; or if operation is in cold weather, use a suitable anti-freeze solution.

It is recommended that a soluble oil in the proportion of 1 ounce per gallon of water be added to the Cooling System.

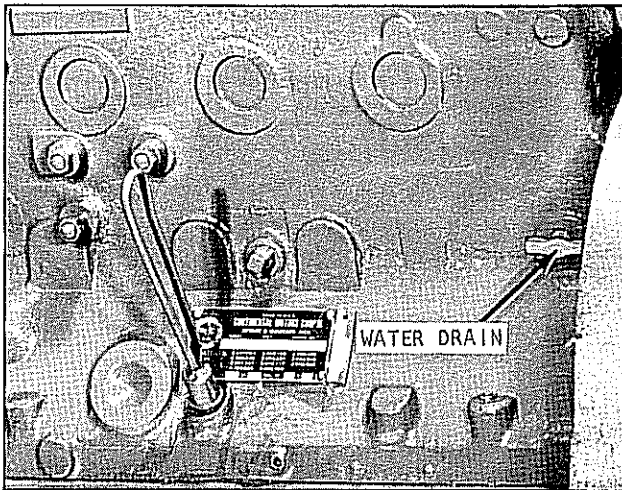

Plate 7008. Cylinder Block Water Drain

CAUTION

NEVER POUR COLD WATER OR COLD ANTI-FREEZE INTO THE RADIATOR OF AN OVERHEATED ENGINE. ALLOW THE ENGINE TO COOL AND AVOID THE DANGER OF CRACKING THE CYLINDER HEAD OR BLOCK. KEEP ENGINE RUNNING WHILE ADDING WATER OR ANTI-FREEZE.

CAUTION

WHEN PERMANENT ANTI-FREEZE OF THE ETHYLENE GLYCOL TYPE IS USED, THE COOLANT SOLUTION MUST CONTAIN AT LEAST 40% WATER.

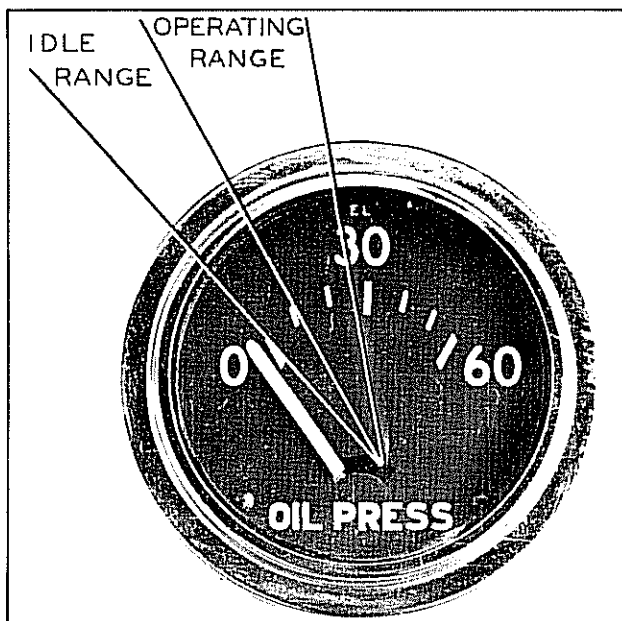

Plate 6417. Oil Pressure Indicator

INSTRUMENT INDICATORS

a. Oil Pressure Indicator. Oil pressure should be at least 7 pounds at idle (400 to 600 R.P.M.) CAUTION: IF THE OIL PRESSURE IS ERRATIC OR FALLS BELOW THE ABOVE LIMIT, STOP THE ENGINE IMMEDIATELY AND FIND THE CAUSE OF THE TROUBLE. REFER TO TROUBLE SHOOTING SECTION FOR THIS INFORMATION.

C A U T I O N

ON NEW MACHINES, AFTER STARTING ENGINE -- RUN IT AT IDLE FOR 5 MINUTES, THEN STOP ENGINE AND RECHECK OIL LEVEL IN CRANKCASE - BRING OIL LEVEL TO HIGH MARK, IF NECESSARY.

b. Temperature Indicator. The water temperature should register 185° to 205° F. after the first ten or fifteen minutes of operation.

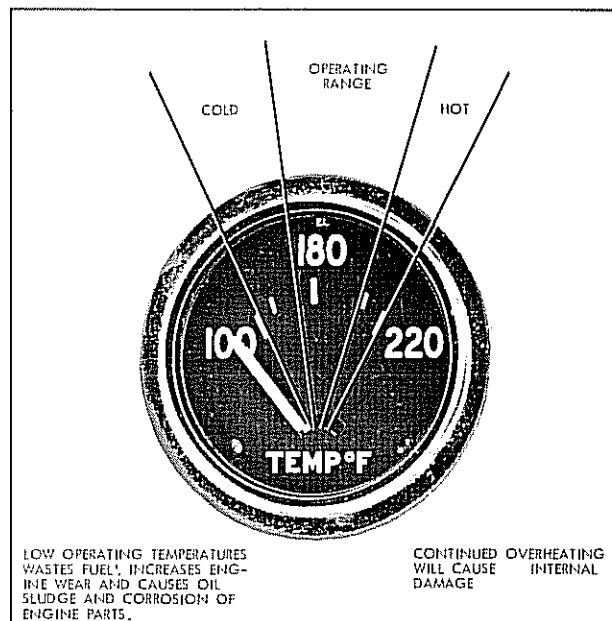

Plate 6287. Temperature Indicator

N O T E

THE COOLANT TEMPERATURE SHOULD REGISTER 185° TO 205° F. AFTER THE FIRST TEN OR FIFTEEN MINUTES OF OPERATION.

c. Ammeter. The ammeter is connected in the alternator and battery circuit in such a manner as to indicate rate of alternator charge or battery discharge with engine at fast idle (approximately 800 R.P.M.)

N O T E

BEFORE PLACING MACHINE IN OPERATION RUN ENGINE A FEW MINUTES TO WARM OIL ESPECIALLY IN COLD OPERATING CONDITIONS. LOW OPERATING TEMPERATURES WASTES FUEL AND INCREASES ENGINE WEAR.

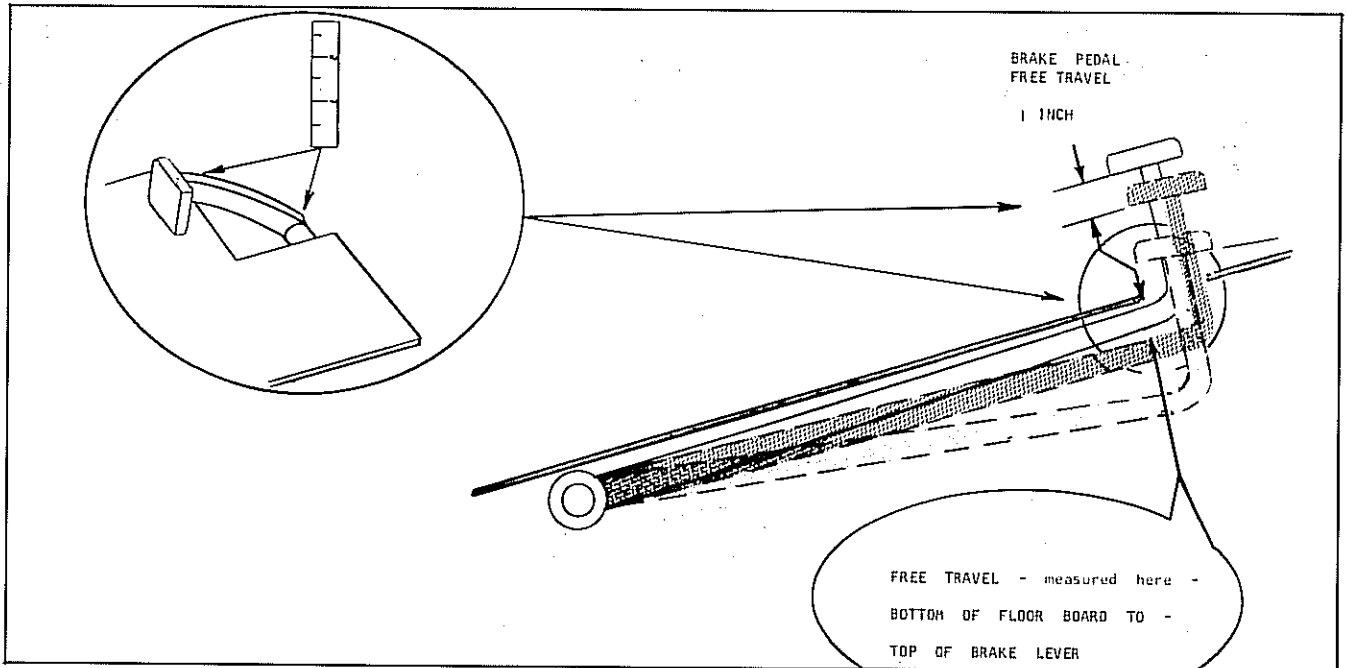

Plate 7042. Brake Pedal Free Travel

BRAKE PEDAL

1. Depress brake pedal and hold foot pressure for at least ten seconds. Pedal must be solid, must not be spongy or drift under foot pressure.

Correct pedal free travel is 1/4 to 1/2 inch when resistance is felt from the master cylinder.

PARKING BRAKE

Make certain that the parking brake is capable of holding the truck on a 3% grade. This should be tested with the parking brake applied and truck out of gear.

If brake operation is not satisfactory, report to designated person in authority.

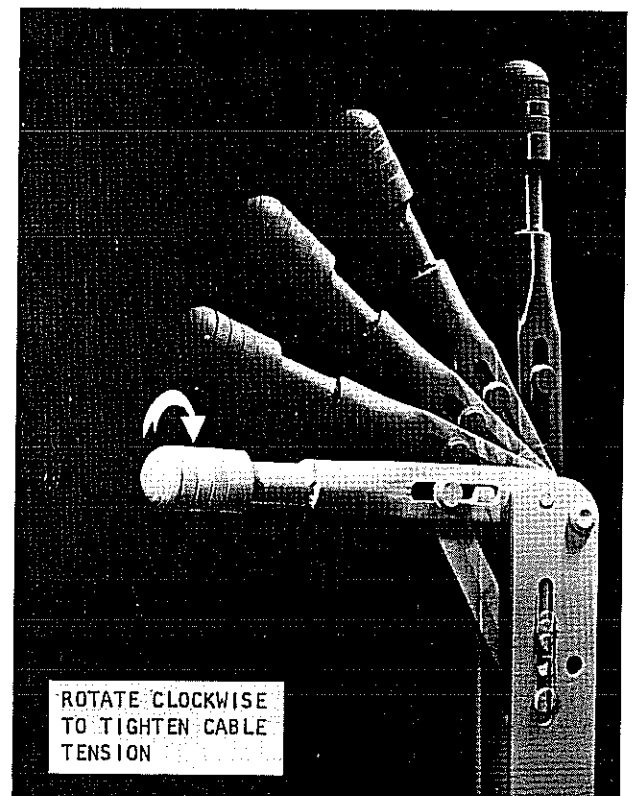

Plate 6505. Parking Brake

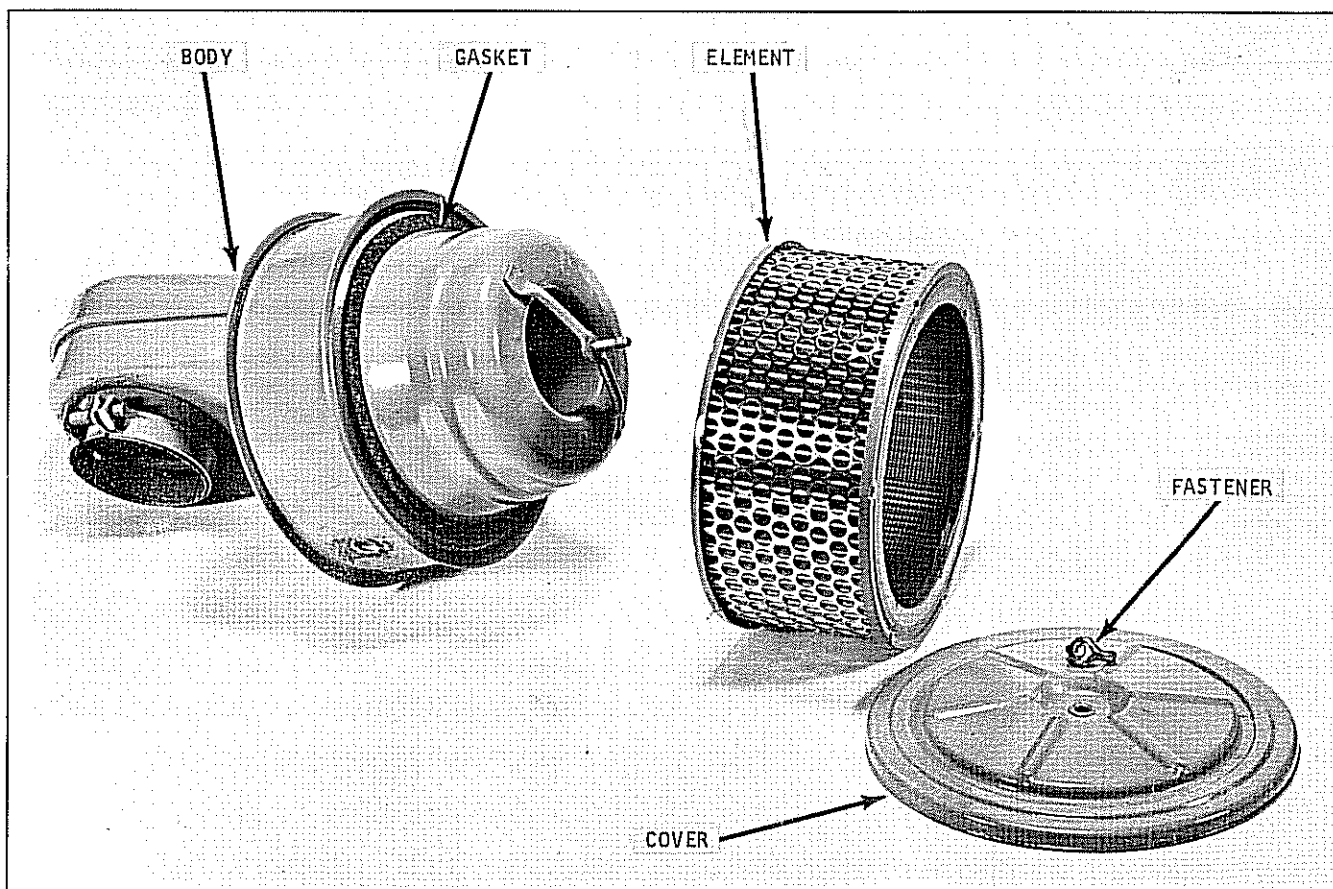

Plate 7428. Air Cleaner

ENGINE AIR CLEANER (DRY TYPE)

Operating conditions determine the air cleaner service periods. The air cleaner should be checked every 8 operating hours and cleaned. This may be necessary more often under dusty operating conditions.

Proper servicing means cleaning unit thoroughly and maintaining air-tight connections between the air cleaner and intake manifold so that all air entering the engine is filtered.

1. Remove air cleaner cartridge (2) and tap cartridge on a hard flat surface until all loose dirt is removed.

2. After cleaning by the above procedure, clean unit with filtered, moisture free, compressed air. Direct air stream from the inside, (thru cartridge) outward at the same time rotating cartridge by hand.

NOTE

IF FILTER CARTRIDGE CANNOT BE PROPERLY CLEANED, REPLACEMENT IS NECESSARY.

Check connections to be sure they are tight thus preventing any air and dirt from entering at these points. Periodically remove air cleaner and check interior for any signs of dirt or dust. If found, this indicates that more frequent cleaning intervals are necessary as the interior should be free of all dirt and dust.

Check gasket for damages, replace if necessary.

NOTE

DEPENDING ON THE TYPE OF OPERATION THE MACHINE IS SUBJECTED TO WILL DETERMINE THE FREQUENCY OF AIR CLEANER MAINTENANCE. HAPHAZARD MAINTENANCE WILL LEAD TO SHORT ENGINE LIFE. AIR CLEANER MAINTENANCE MAY SEEM TRIVIAL, BUT IT CAN MEAN LONGER ENGINE LIFE, LESS ENGINE UPKEEP AND BETTER ECONOMY PROVIDED PROPER MAINTENANCE IS EXERCISED. CLOSE OBSERVANCE AND COMMON SENSE CAN BEST DETERMINE THE FREQUENCY OF AIR CLEANER MAINTENANCE.

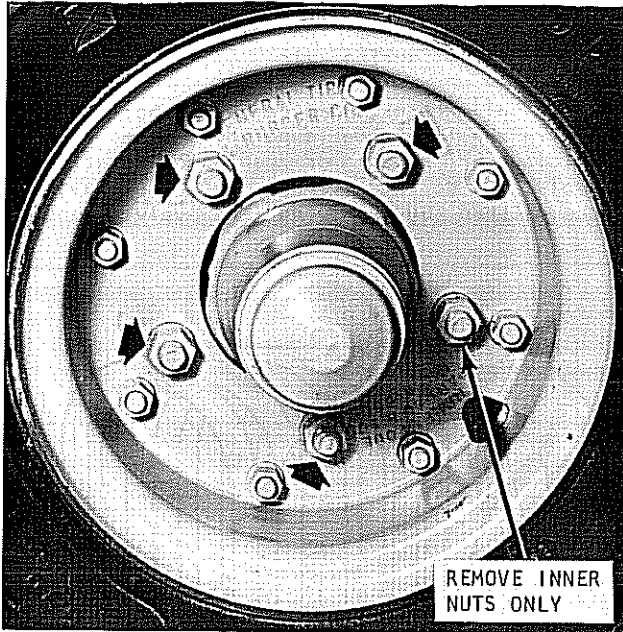

Plate 7425. Front (Steer) Wheels
Split Rims

W A R N I N G

BEFORE REMOVING TIRE FROM RIM, RELEASE ALL AIR FROM THE TIRE BY REMOVING VALVE STEM CORE.

W A R N I N G

TO REMOVE WHEEL ASSEMBLY FROM VEHICLE --
REMOVE INNER WHEEL STUD NUTS ONLY.

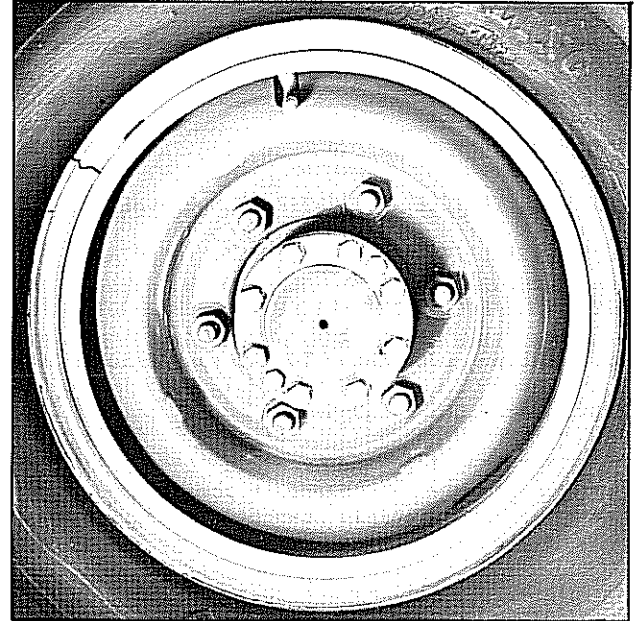

Plate 7716. Rear (Drive) Wheels
Drop-Center Tubeless Rims

W A R N I N G

IN ALL CASES, WHEN REMOVING TIRES WITH SPLIT RIMS FROM THE MACHINE FOR REPAIR OR PERIODIC ROTATION, COMPLETELY DEFLATE TIRES. THIS MAY BE ACCOMPLISHED BY REMOVING THE VALVE STEM CORE.

W A R N I N G

IF TIRES ARE NOT DEFLATED, AND THE OUTER WHEEL STUD NUTS ARE REMOVED PRIOR TO THE REMOVAL OF THE INNER WHEEL STUD NUTS, IT IS POSSIBLE FOR THE SPLIT RIMS TO SEPARATE WITH GREAT FORCE AND COULD RESULT IN SERIOUS INJURY TO ANYONE STRUCK BY IT.

N O T E
REFER TO FOLLOWING PAGES.

TIRE AND RIM MAINTENANCE

WARNING

AN INFLATED TIRE AND RIM CAN BE VERY DANGEROUS. MANY ACCIDENTS, SOME FATAL, HAVE RESULTED FROM IMPROPER HANDLING AND OPERATION OF VEHICLE RIMS TIRES AND WHEELS. IT IS, THEREFORE, OF THE UTMOST IMPORTANCE THAT THE FOLLOWING PRECAUTIONS BE NOTED BY ALL PERSONS CONCERNED TO AVOID PERSONAL INJURY AND COSTLY DAMAGE.

1. After raising the vehicle and prior to removal of wheels, place blocking under the frame so the vehicle cannot become lowered by accident. Blocking must be of adequate strength to support the weight of the vehicle.

2. Some vehicles use a rim that has a inner half and a outer half. The two halves are held together by bolts and by the wheel attaching bolts. See Plate 7613. In all cases the air should be removed from the tire by removing the valve core before attempting to remove the wheel from the vehicle. The tire should not be inflated while it is "off" the vehicle. Check for security of all rim retainment bolts and wheel attaching bolts before

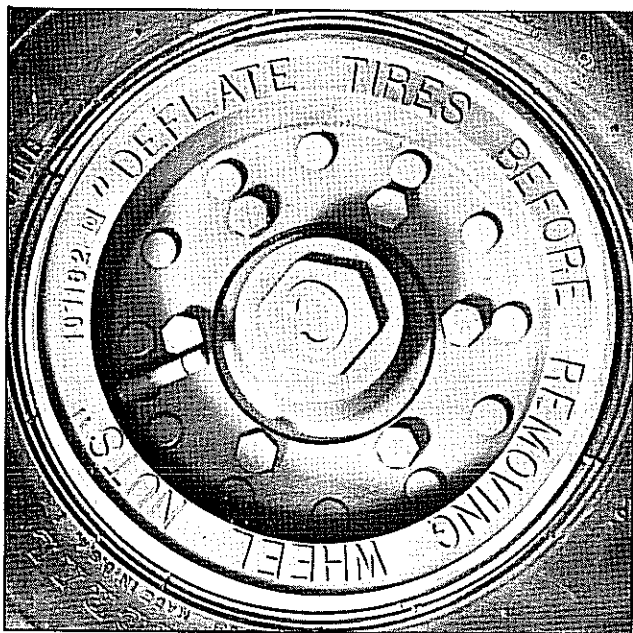

Plate 7613. Typical Wheel with Inner and Outer Halves

inflating tire. A clip-on type air chuck should be used so the operator can stand to one side during tire inflation.

3. In all cases, when removing wheels equipped with the lock ring type rim from the vehicle for repair or periodic rotation, completely deflate tires. This is best accomplished by removing the valve core.

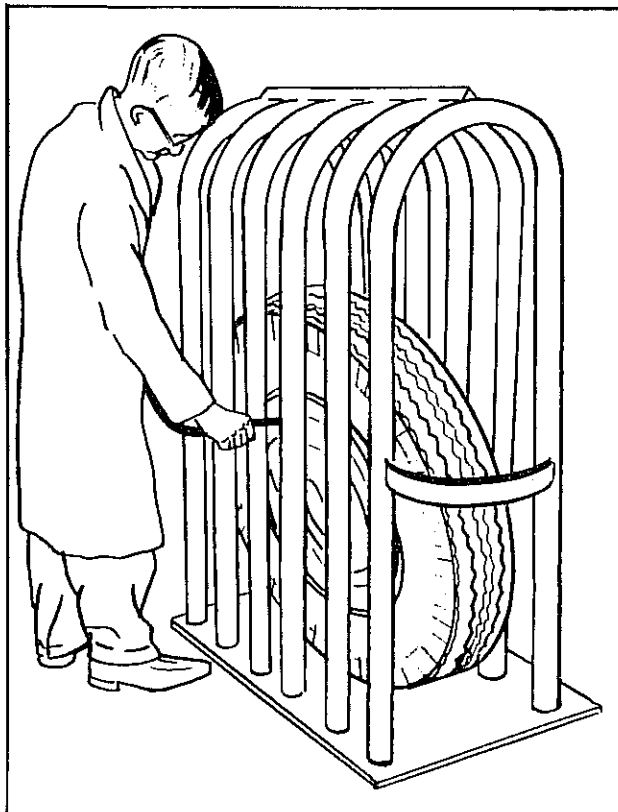

Plate 7614. Typical Safety Cage

4. Tires used on the lock ring type rim should be inflated in a safety cage. See Plate 7614. Insure that rings are properly seated prior to inflation. An inflated tire contains potentially explosive energy that can blow rings loose. A clip-on type air chuck should also be used, so the operator can stand to one side during tire inflation.

5. Use properly matched parts only. Rim base and rings must be matched according to manufacturer, size and type. This information is stamped on each part.

6. Remove rust and other foreign matter. Accumulation of such material in the rim gutter can prevent the proper fitting of rings. Parts that are excessively corroded are weakened and should be replaced. Use



INDUSTRIAL TRUCK DIVISION



TIRE AND RIM MAINTENANCE

of a rust preventative compound (not containing water) during mounting will minimize rusting.

7. Do not use over-size or over-inflated tires. Use only preferred or alternate size rims for tires and do not exceed recommended air pressures. It is also important to maintain uniform inflation in both tires of a dual assembly so that weight is equally sustained.

8. Do not run vehicle on one tire of a dual assembly. Never re-inflate a tire that has been run flat without first thoroughly inspecting it and the rim assembly. It is especially important to make sure the lock ring is secure in the gutter and has not been damaged prior to re-inflation.

9. Completely deflate tire prior to demounting. Remove valve core to insure complete deflation. Check for damage or worn parts. Mark defective parts for destruction to preclude their future use. Abuse during operation or in mounting the tire can cause dents, cracks or distortions which weaken the parts and prevent safe, proper assembly. Replace defective parts with new parts of the correct size and type.

10. Periodically check clamps and wheel nuts. Loose clamps can cause dangerous rim slippage or detachment of rim and tire from the vehicle. Loose wheel nuts can cause severe damage to rim and hub. Excessive torque is also dangerous in that it can cause stud and rim breakage.

11. Even with the best of maintenance practices, cuts will still be a source of tire trouble. The correct procedure for handling and repairing tires should be given careful attention. Close inspection of all tires should be made at the time of inflation check, and all tires having cuts that penetrate into the cord body should be taken off for proper repair.

Failure to make regular inspections and repairs, when needed, will result in further deterioration of the cord body and eventually a blowout. Small rocks and dirt will get into shallow cuts in the tread and if neglected will gradually be pounded through the cord body.

One simple method to forestall this action is to clean out the cut with an Awl or similar tool to remove any stones or other matter which may be lodged in the cut. Use a sharp, narrow-bladed knife and cut away the rubber around the cut to form a cone-shaped cavity extending to the bottom of the injury. The sides of the cavity should be slanted enough to prevent stones from wedging into it. Tires with cuts treated in this manner may be continued in service without danger of further growth of these injuries. If a tire has at least one deep cut that requires a repair, then all smaller cuts may be quickly and economically repaired and vulcanized by the steam kettle method.

NOTE

IT IS NOT RECOMMENDED THAT TIRES WITH BREAKS BE USED AGAIN.

If uneven tire wear is evident, wheel alignment should be checked.

LUBRICATION AND PREVENTIVE MAINTENANCE

DIRECTIONAL TREAD TIRES

All directional tread tires are to be mounted in the correct position with respect to the arrow cast on the side of the tire as explained and illustrated below.

Directional Tread Dual Tires:

1. Inside dual tire arrow to point in the direction of forward rotation, see Plate 6422.

(Rotate wheel to bring arrow on tire above the wheel. Arrow must point toward front of truck.)

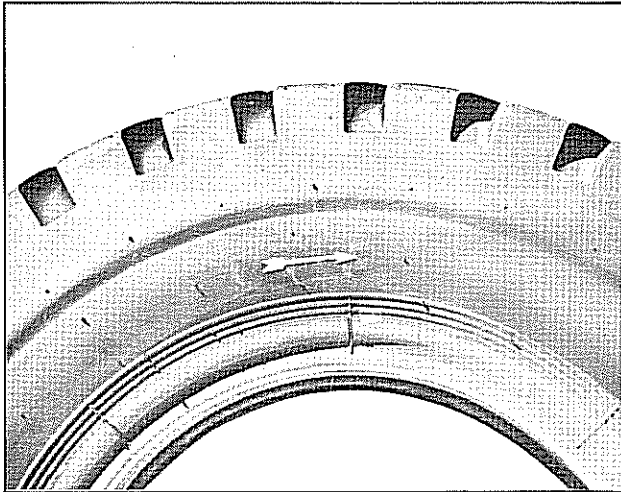

Plate 6422. Inside Dual Tire
(or Single Drive Tire)
(Arrow to point toward front of truck)

2. Outside dual tire arrow to point in the direction of rearward rotation, see Plate 6423.

(Rotate wheel to bring arrow on tire above the wheel. Arrow must point toward rear of truck.)

Directional Tread Single Drive Tires:

1. Tire arrow to point in the direction of forward rotation, see Plate 6422.

(Rotate wheel to bring arrow on tire above the wheel. Arrow must point toward front of truck, see Plate 6422.)

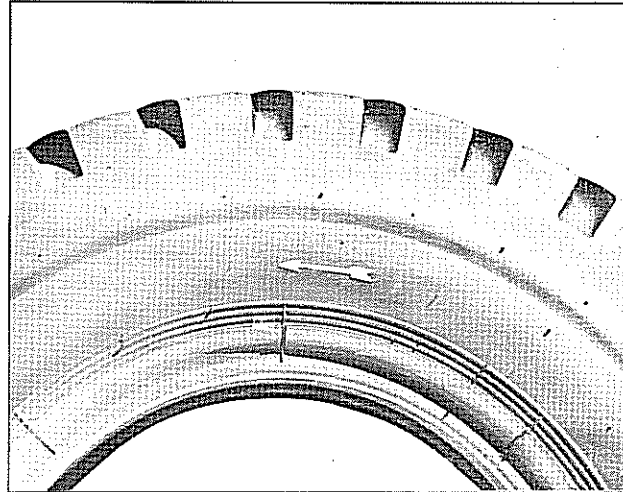

Plate 6423. Outside Dual Tire
(Arrow to point toward rear of truck)

SOLID OR CUSHION TIRE AND RIM MAINTENANCE

1. Inspect tires regularly - remove all sharp objects picked up by treads before they have a chance to cut further into the rubber and cause chipping or possible separation of the rubber from the base metal.
2. Avoid overloading and do not allow vehicle to stand under heavy loads for prolonged periods as this will cause a "flat" spot on the tires.
3. Check steering axle alignment regularly to protect against fast, irregular tread wear and separation.
4. If rubber tires come in contact with oils, grease, and gasoline they should be wiped off without delay.
5. Regular lubrication of all wheel bearings will assure free-rolling and elimination of tire drag when stopping or starting.

100 HOUR

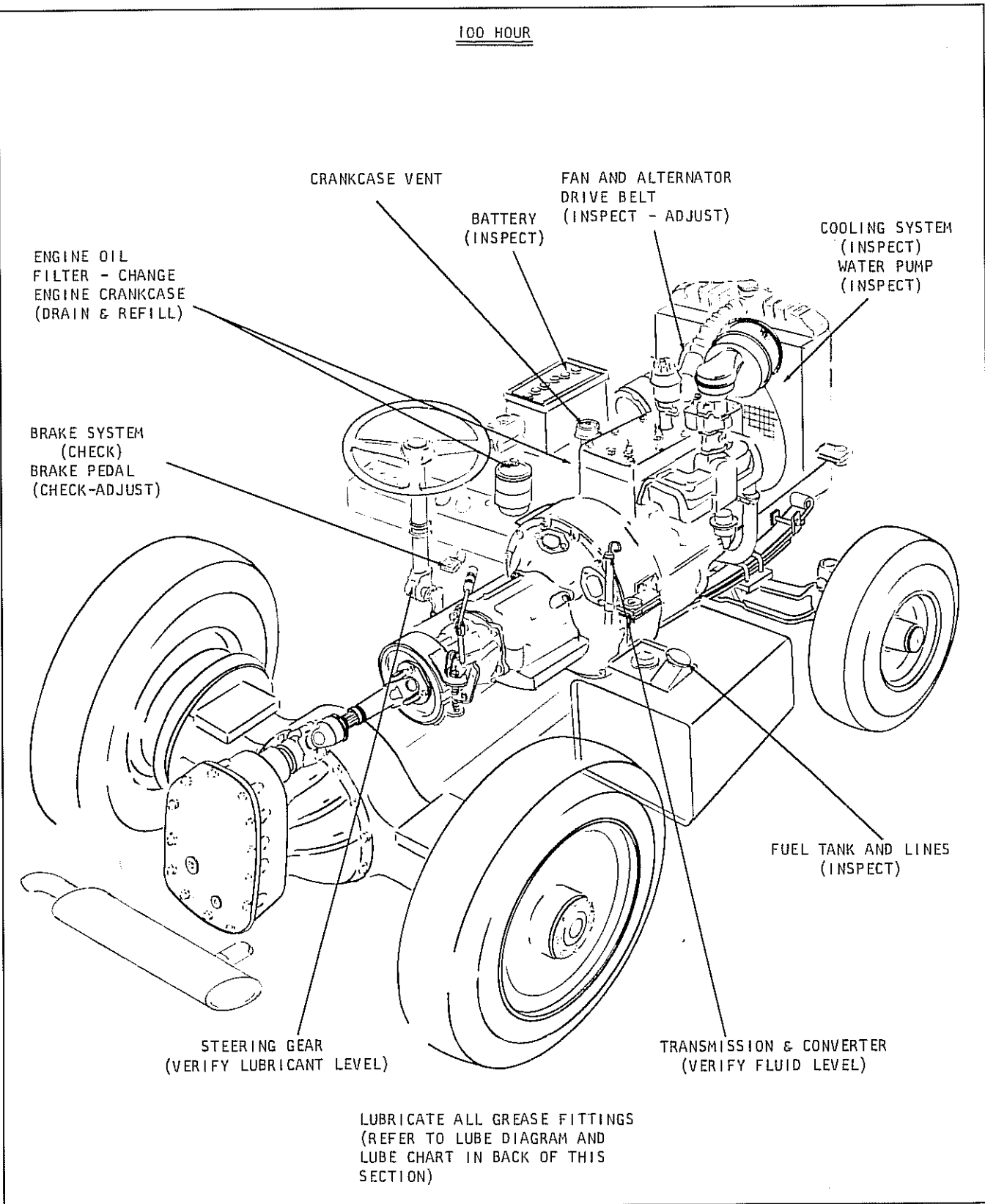

Plate 7734. Lubrication and Preventive Maintenance Illustration

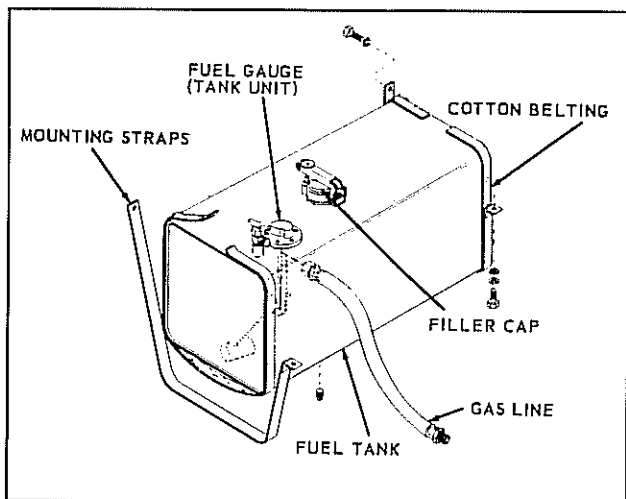

Plate 6275. Fuel Tank and Lines

CONVERTER, TRANSMISSION. Verify fluid level, fill if necessary with Automatic Transmission Fluid Type "A" (Armour Qualified). A combination filler neck and fluid level stick is located in the Transmission Axle Adaptor Housing for filling or checking fluid level.

With directional selector in "NEUTRAL" position, start engine and operate approximately four minutes. With engine running at idle, check fluid level. Fill if necessary to "FULL" mark on fluid level stick.

FUEL LINES. Make certain that fuel line connections are secure. Check fuel lines for obstructions and leaks.

ENGINE CRANKCASE

Every 100 operating hours, drain and refill. (Drain at operating temperatures). Refill, then run engine a few minutes and add oil as necessary to bring oil level to full mark indicated on the dipstick.

Crankcase Capacity — Refer to Specifications
 S.A.E. 10W 0° to 32° F.
 S.A.E. 20W 32° to 75° F.
 S.A.E. 30 above 75° F.
 or use 10W ——— 30 MULTI-GRADE OIL

ENGINE CRANKCASE VENTILATION BREATHER

Remove breather and oil cup by releasing spring clips. Dislodge foreign particles by washing in a Stoddard type solvent until clean. Allow to air dry. Fill oil cup to level mark with oil of same viscosity as used in engine. Replace breather after it is completely air dried.

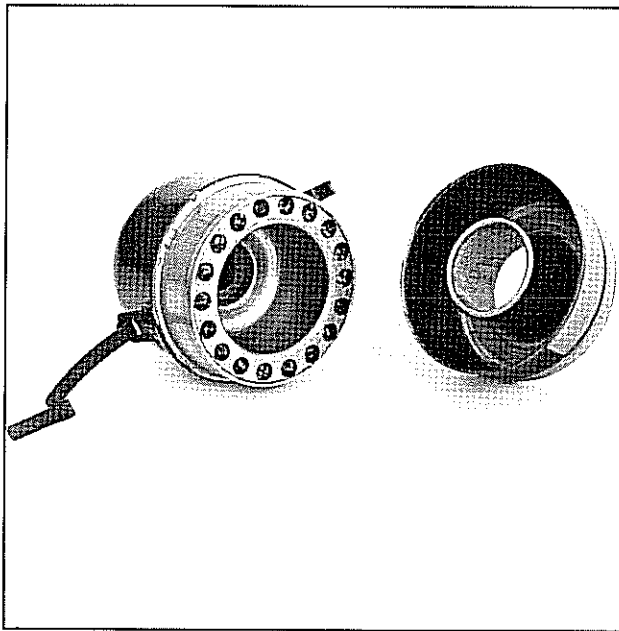

Plate 7033. Engine Breather

ENGINE OIL FILTER

The oil filter element is of the replaceable type. The element should be changed whenever the crankcase is drained. To remove the element, remove oil filter cover screw and gasket, oil filter cover, cover spring and cover gasket. Lift out oil filter element. Install new element after draining and thoroughly cleaning filter case. Install new gaskets and replace cover spring, oil filter cover and secure with oil filter cover screw.

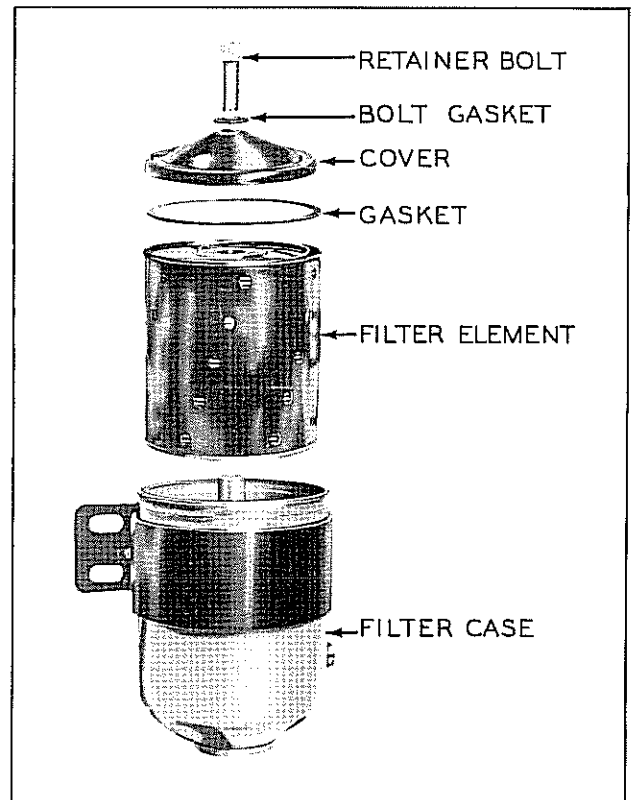

Plate 6332. Engine Oil Filter

CAUTION

START ENGINE, RUN AT IDLE FOR A FEW MINUTES, CHECK COVER AND COVER SCREW FOR LEAKS.

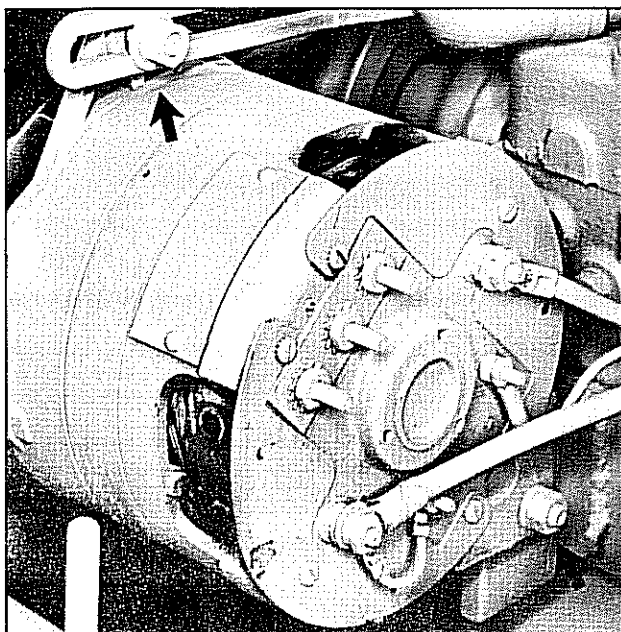

Plate 7717. Typical
Drive Belt Adjustment

FAN AND ALTERNATOR DRIVE BELT

The drive belt should have finger pressure deflection of 3/4 to 1 inch midway on long span.

WARNING

CHECK FAN BELT DEFLECTION WITH ENGINE OFF.

NOTE

IF THE FAN CAN BE ROTATED EASILY WITH A FINGER PULLING ON THE FAN BLADES, THE BELT IS TOO LOOSE AND MUST BE ADJUSTED.

If the belt requires adjustment, use the following procedure.

1. Loosen alternator brace adjusting bolt and two lower mounting bolts.
2. Move alternator toward cylinder block to loosen drive belt and away from cylinder block to tighten belt. Tighten bolts when correct finger deflection is obtained.

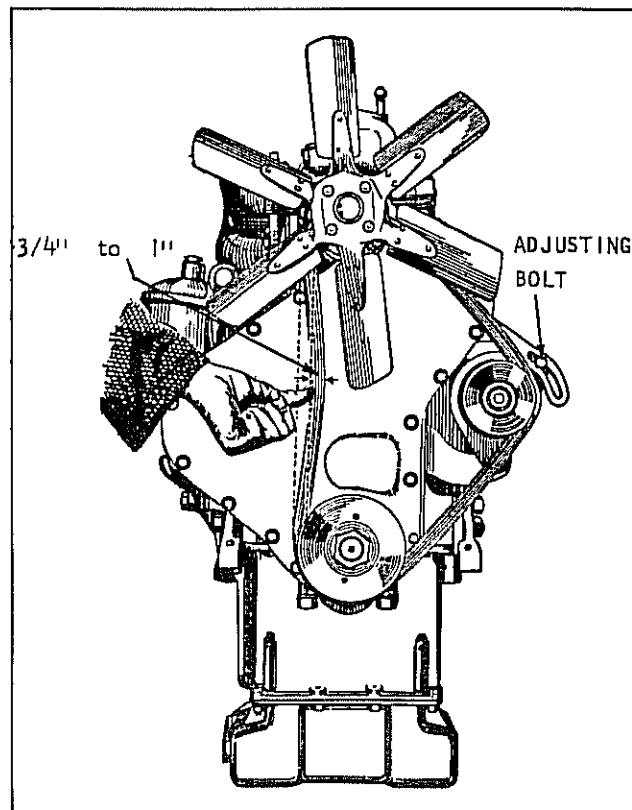

Plate 6632. Typical
Belt Deflection Check

NOTE

WHEN TIGHTENING BELT TENSION, APPLY PRESSURE AGAINST THE STATOR LAMINATIONS BETWEEN THE END FRAMES, AND NOT AGAINST EITHER END FRAME. WHEN ADJUSTING FOR DEFLECTION, PULL ALTERNATOR BY HAND, DO NOT USE A PRY BAR.

CAUTION

EXERCISE CAUTION WHEN ADJUSTING BELTS. BELTS ADJUSTED TOO TIGHT WILL VERY LIKELY CAUSE BEARING DAMAGE. CONVERSELY, BELTS ADJUSTED TOO LOOSE WILL RESULT IN BELT WEAR AND HIGH ENGINE TEMPERATURE DUE TO BELT SLIPPAGE.



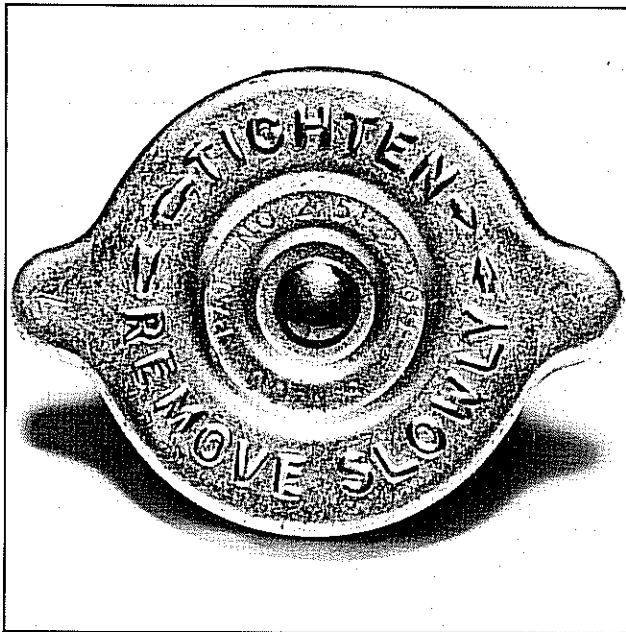

Plate 6458. Radiator Pressure Cap

WARNING

USE EXTREME CARE IN REMOVING THE RADIATOR PRESSURE CAP. IN PRESSURE SYSTEMS, THE SUDDEN RELEASE OF PRESSURE CAN CAUSE A STEAM FLASH AND THE FLASH, OR THE LOOSENED CAP CAN CAUSE SERIOUS PERSONAL INJURY. LOOSEN CAP SLOWLY AND ALLOW STEAM TO ESCAPE.

COOLING SYSTEM

Check radiator, hoses and water pump for leaks.

Add proper amount of water or anti-freeze solution to cooling system. If anti-freeze is not available and machine is to be at rest for an appreciable length of time, drain system when temperature is likely to be 32° F, or lower. If water is added to radiator containing anti-freeze solution, always test solution in radiator with a hydrometer to determine the degree of protection. For proper amount of anti-freeze solution required to protect the cooling system, refer to instructions on anti-freeze container.

NOTE

COOLING SYSTEM CAPACITY - REFER TO SPECIFICATIONS.

Accumulated foreign material should be blown from radiator fins with compressed air. Direct air stream through radiator fins towards engine to make this process effective.

BRAKE PEDAL "FREE TRAVEL"

Using a rule, measure pedal free travel. Clearance should be measured from top pedal position to where pedal meets resistance from the master cylinder. Depress brake pedal by hand. When pedal meets resistance from the master cylinder, the distance traveled should be 1/4" to 1/2" if free travel is incorrect, adjust as follows:

1. Loosen lock nut, see Plate 6633.
2. Rotate adjuster to obtain specified pedal free travel.
3. Tighten lock nut to hold adjustment.

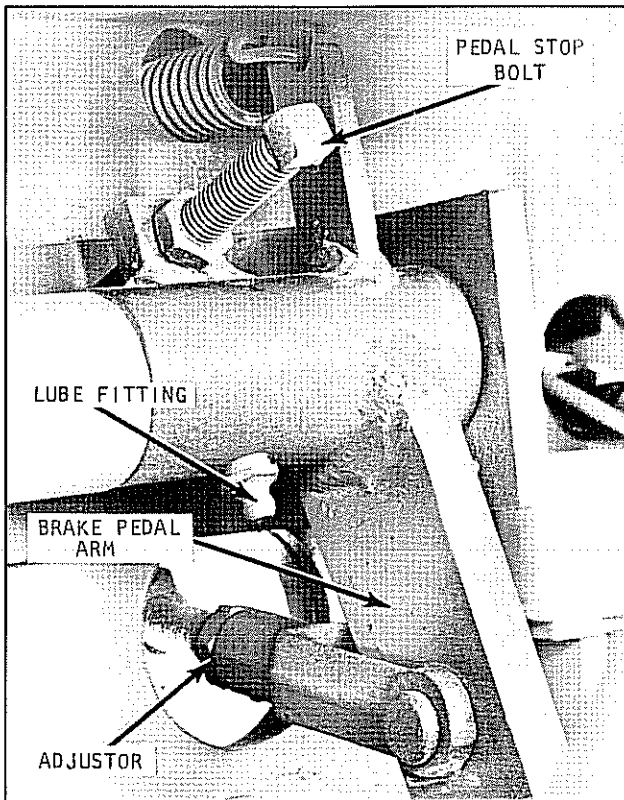

Plate 7718. "Typical"
Brake Pedal Adjustors

ACTUATION STROKE

If brake pedal travels beyond this point, this indicates either lack of fluid in the master cylinder; air in the system, or the brake linings require adjustment or replacement.

--- CLEARANCE - measured here -
TOP PEDAL POSITION -TO- WHERE
PEDAL MEETS RESISTANCE FROM
THE MASTER CYLINDER.

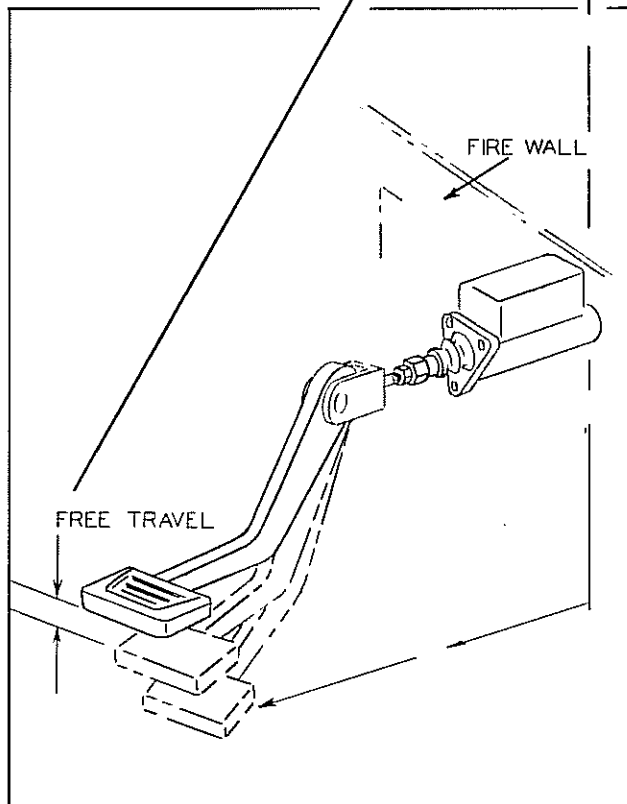

Plate 7719. "Typical"
Brake Pedal Check and Adjustment

BRAKE SYSTEM

Check brake fluid level in the master cylinder. Brake fluid should be within 1/4 inch of the top. Fill with S.A.E. 70 R3 Heavy Duty Hydraulic Brake Fluid.

Master Cylinder Filler Cap Vent Hole:
Check cap vent hole for obstruction. Vent hole must be open at all times. Clean if necessary, see Plate 6633.

BRAKE PEDAL

WARNING

CORRECT BRAKE PEDAL FREE TRAVEL IS IMPORTANT FOR SAFE OPERATING BRAKES.

A correctly adjusted brake pedal is important so that the internal ports in the master cylinder are not blocked by the cylinder piston. The following lists two important reasons for proper brake pedal free travel.

Inadequate pedal free travel will block the internal ports so that upon releasing the brake pedal fluid will be trapped in the lines and hold the brake linings in contact with the brake drums. Resulting in lining wear and excessive fuel consumption.

Brake Pedal Adjustment: Refer to Plate 7042 and follow the instructions and diagrams.

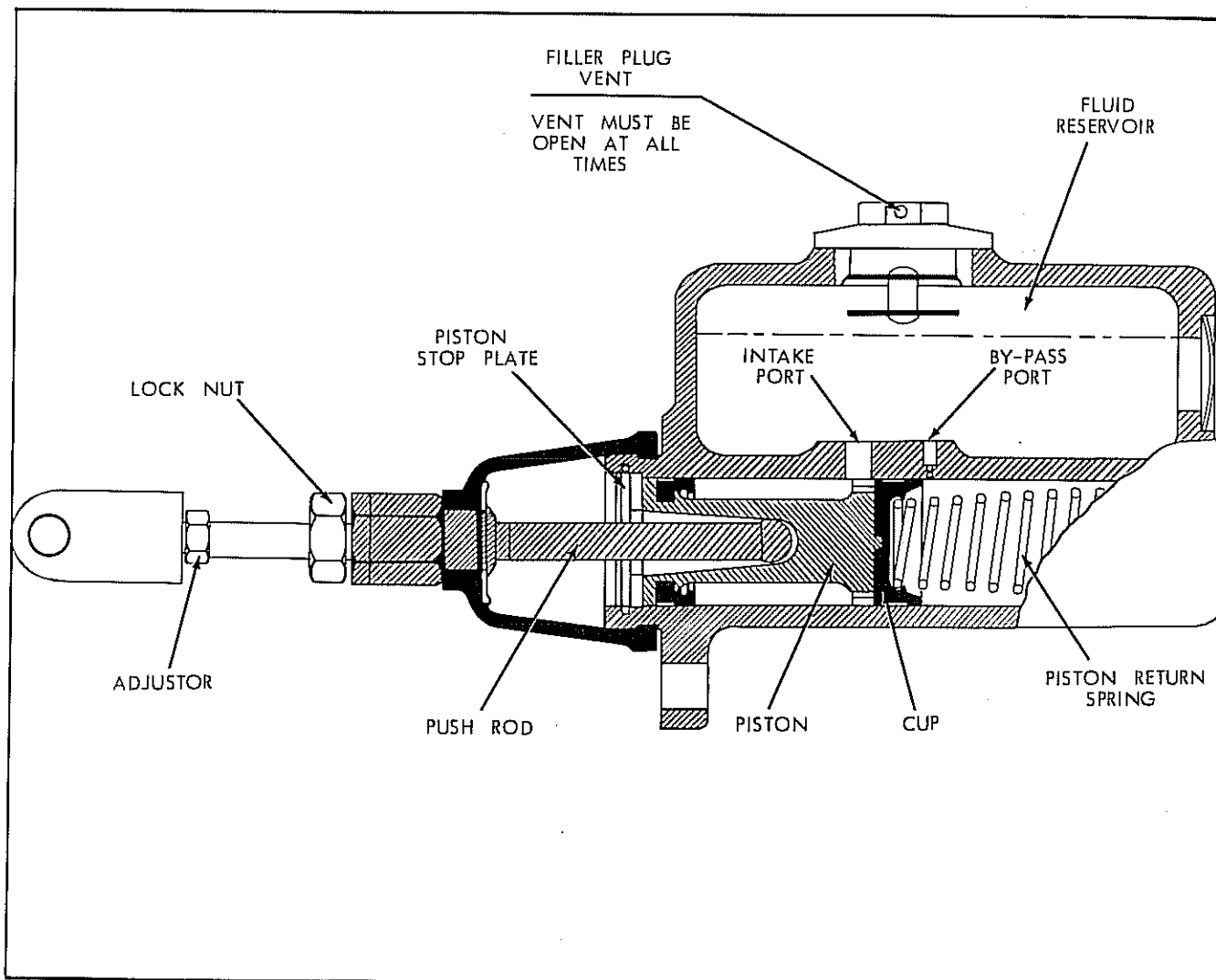

Plate 6633. Brake Pedal Adjustment



INDUSTRIAL TRUCK DIVISION



LUBRICATION AND PREVENTIVE MAINTENANCE

ALTERNATOR - BATTERY - ELECTRICAL SYSTEM

CAUTION

IMPORTANT — Since the alternator and regulator are designed for use on only one polarity system, the following precautions must be observed when working on the charging circuit. Failure to observe these precautions will result in serious damage to the electrical equipment.

1. When installing a BATTERY, always make absolutely sure the ground polarity of the battery and the ground polarity of the alternator are the same.

2. When connecting a BOOSTER BATTERY, make certain to connect the negative battery terminals together and the positive battery terminals together.

3. When connecting a CHARGER to the battery, connect the charger positive lead to the battery positive terminal and the negative lead to the battery negative terminal.

4. NEVER OPERATE THE ALTERNATOR ON OPEN CIRCUIT. Make absolutely certain all connections in the circuit are secure.

5. Do not short across or ground any of the terminals on the alternator or regulator.

6. Do not attempt to polarize the alternator.

LUBRICATE MACHINE

NOTE

WHEN LUBRICATING THE VEHICLE, MAKE A VISUAL INSPECTION OF ALL ELECTRICAL WIRING. LUBRICATE ALL MISCELLANEOUS LINKAGE WITH S.A.E. NUMBER 20 OIL.

STEER GEAR

Verify lubricant level, fill if necessary with S.A.E. 140 Gear Lube (Summer), S.A.E. 90 Gear Lube (Winter).

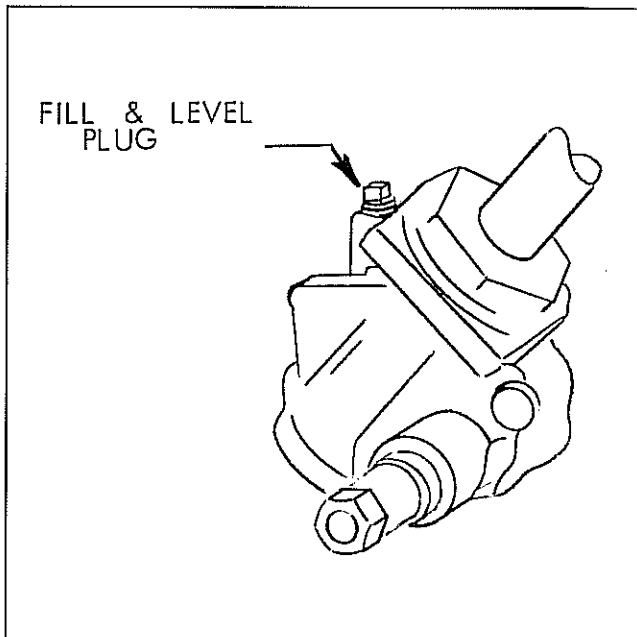

Plate 6429. Steering Gear

BATTERY INSPECTION

Check battery fluid level. Make sure that all connections are tight at battery, starter, generator, voltage regulator, distributor and spark plugs.

Take hydrometer reading of electrolyte to determine state of charge. Charge battery if reading is below 1.225 at 24°C (75°F), or below 1.265, if machine is operating in cold climates. If machine is operating in tropical areas, in which freezing weather is not encountered, the full charge specific gravity reading may be lowered from 1.375 to 1.225 by diluting the electrolyte with distilled water.

CAUTION

MAKE CERTAIN THAT SPECIFIC GRAVITY IS ADJUSTED TO NORMAL IF MACHINE IS SHIPPED

TO AREAS WHERE IT WILL BE EXPOSED TO FREEZING TEMPERATURES.

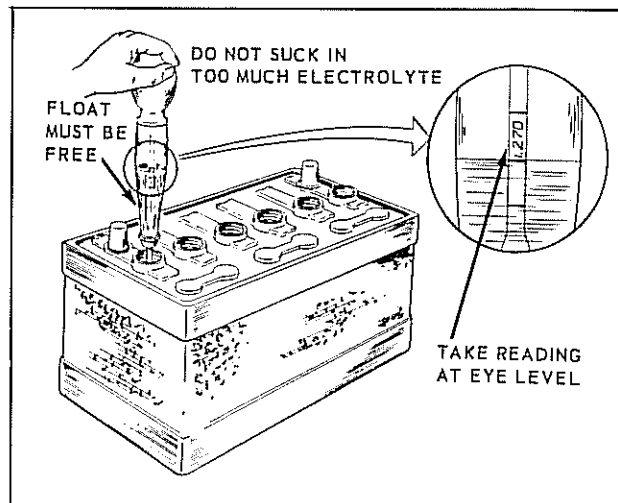

Plate 6271. Checking Specific Gravity of Battery
NOTE

ADD DISTILLED WATER IMMEDIATELY BEFORE CHARGING. DO NOT ADD DISTILLED WATER TO A BATTERY IMMEDIATELY AFTER A CHARGE.

TO TEST BATTERY

1. Connect positive lead of test voltmeter to positive terminal of battery and negative lead of voltmeter to negative (grounded) terminal of battery.
2. Record voltmeter reading.
3. Now pull high tension wire from ignition coil so engine will not start when starter is engaged.
4. Turn ignition switch to start position and check the voltmeter reading.
5. Compare this reading with the previously recorded reading.

If the voltage drop was more than 4 volts, or if the second reading registered below 8 volts, battery should be replaced.

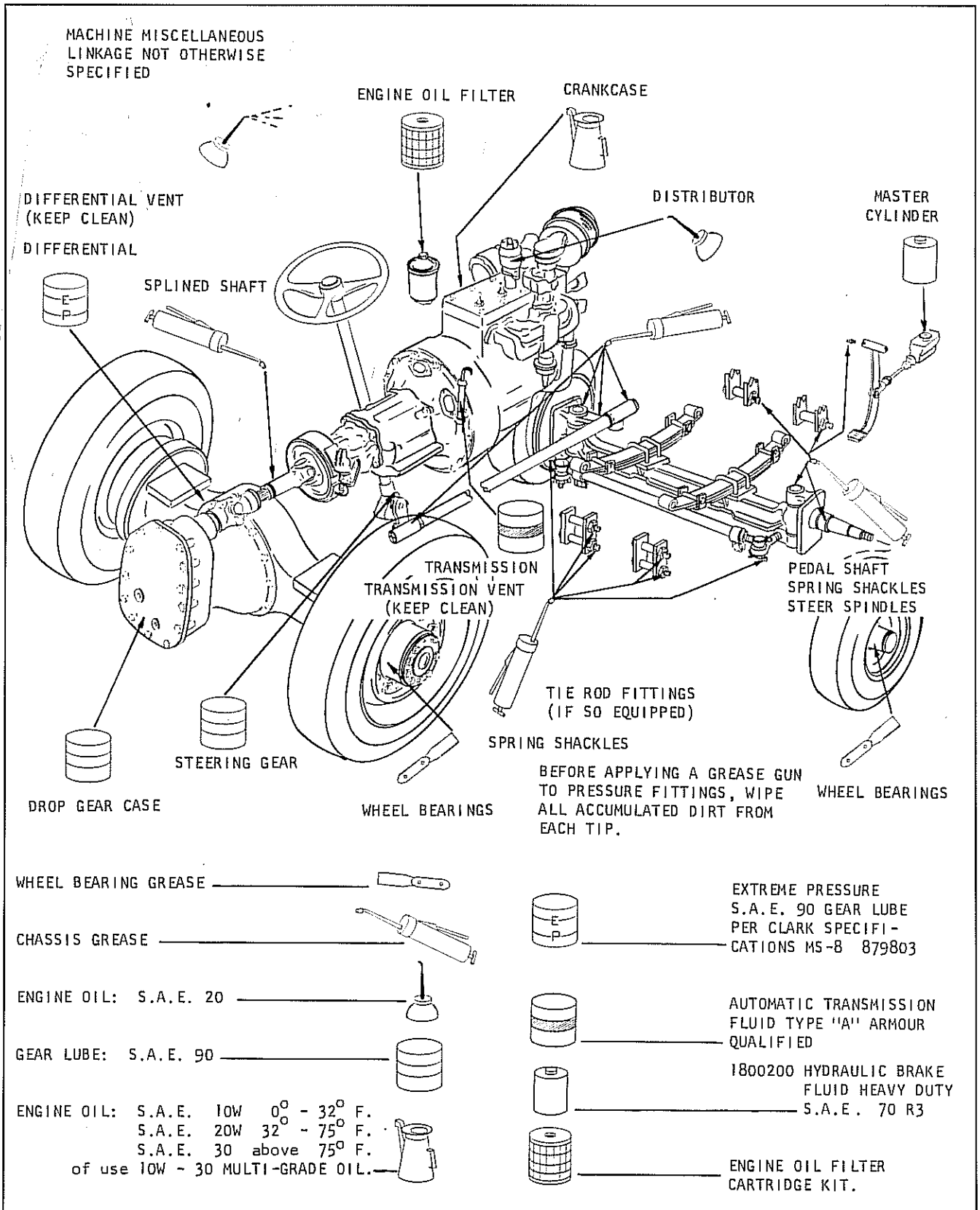

500 HOUR

CHECK SECURITY OF
ALL NUTS, BOLTS AND
CAPSCREWS.

STEERING LINKAGE
(ADJUST)

STEERING GEAR
(ADJUST)

FUEL PUMP AND SCREEN
(INSPECT - CLEAN)

EXHAUST SYSTEM
(INSPECT)

TRANSMISSION & CONVERTER
(DRAIN AND REFILL)

STEAM CLEAN COMPLETE MACHINE BEFORE PERFORMING THE
500 HOUR LUBRICATION AND PREVENTIVE MAINTENANCE.

Plate 7735. Lubrication and Preventive Maintenance Illustration

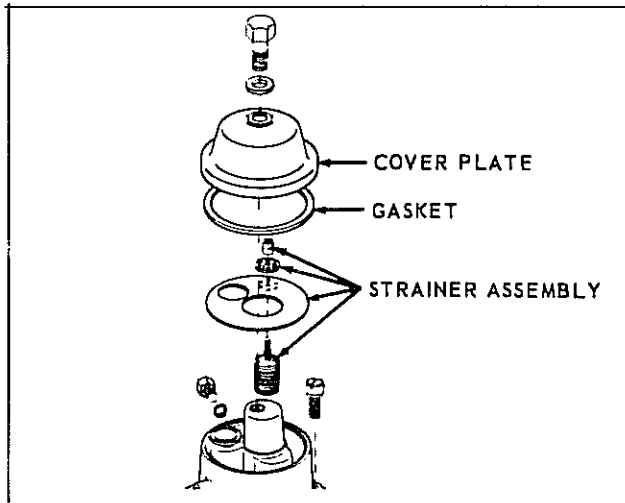

Plate 6279. Cleaning Fuel Pump Strainer Assembly

FUEL PUMP STRAINER

The fuel strainer assembly incorporated in the pump body should be cleaned every 500 operating hours. This may be accomplished by the following procedure:

- a. Shut off fuel supply valve at fuel tank outlet.
- b. Remove heat deflector.
- c. Loosen bolt in top of fuel pump cover plate and remove cover plate, gasket and strainer assembly from pump.
- d. Clean strainer assembly with compressed air, making sure that no dirt particles remain.
- e. Reinstall strainer assembly and gasket. Replace gasket, do not reuse old gasket.
- f. Replace cover plate on fuel pump and tighten bolt.
- g. Turn fuel supply valve on at fuel tank outlet.
- h. Replace heat deflector.

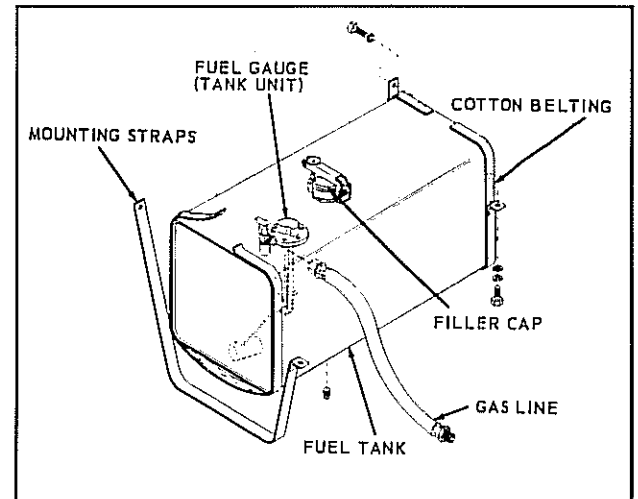

Plate 6275. Fuel Tank and Lines

FUEL PUMP

To determine if the fuel pump is defective, remove the fuel tank supply line at the pump and blow out line with compressed air to remove any possible obstructions. Reconnect fuel tank line and disconnect pump to carburetor line. Install a fuel pressure gauge, by placing a "T" in the line, and run engine at 1800 R.P.M. with all lines connected. Fuel pump pressure should be between 1 1/2 and 2 1/4 pounds. If the fuel pump pressure is not within this range the pump should be removed for repair or replacement.

CAUTION

TO AVOID CREATING A FIRE HAZARD CARE SHOULD BE TAKEN SO THAT GASOLINE IS NOT SPILLED DURING THESE OPERATIONS.

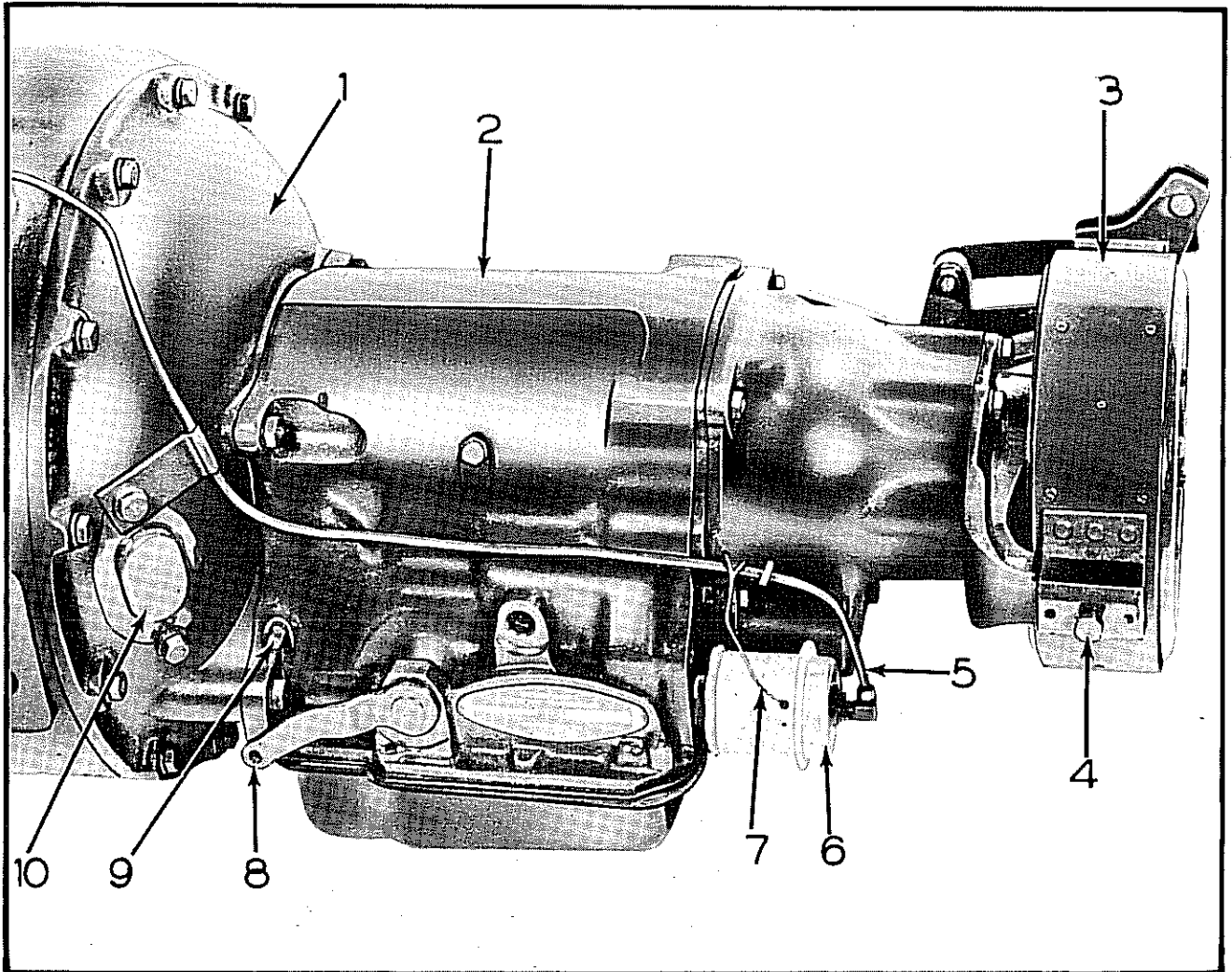

- | | |
|--------------------------------------|-------------------------------------|
| 1. Torque converter housing | 6. Vacuum control and solenoid unit |
| 2. Transmission | 7. Not Used |
| 3. Parking Brake | 8. Manual shift lever |
| 4. Anchor clip screw | 9. Pressure gauge port pipe plug |
| 5. Carburetor-to-vacuum control line | 10. Converter housing cover plate |

Plate 5371. Transmission, Drain, and Refill

TRANSMISSION

Drain and refill to proper level with Automatic Transmission Fluid Type "A" (Armour Qualified).

Fill to full mark on oil level dipstick.

Run engine at fast idle for approximately 3 minutes to prime converter.

With engine running at idle, check oil level, add as required. Refer to specifications.

CAUTION

DO NOT USE FLUSHING OIL OR COMPOUND TO FLUSH SYSTEM.

STEERING GEAR

Steering gear adjustments must be made in the following manner (see Plates 6636 and 6637).

Always check worm bearing thrust adjustment, and adjust if necessary, before making sector gear lash adjustment.

Before making above adjustments, the following preliminary operations are necessary.

1. Disconnect steering drag link from pitman arm. Note relative position of drag link parts when disconnecting link so the parts may be re-assembled correctly.

2. Check lubricant level in steering gear housing. If low, add enough lubricant to bring level up to filler plug hole. (Use S.A.E. 140 Gear Lube in summer, S.A.E. 90 Gear Lube in winter.)

3. Tighten steering gear housing to frame side member bolts, see Plate 6636.

4. Determine straight-ahead position of steering mechanism by turning steering wheel to extreme right.

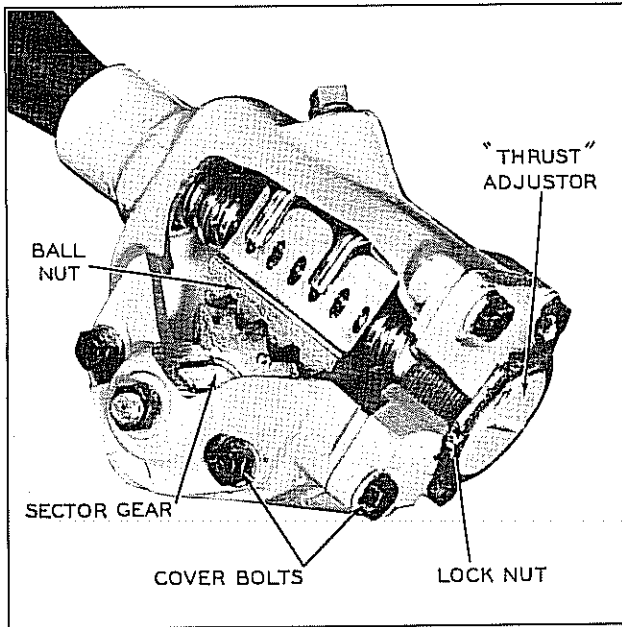

Plate 6636. Steering Gear Thrust Adjustment (Worm Bearings)

CAUTION

APPROACH EXTREME ENDS CAUTIOUSLY; WORM BALL NUT MUST NOT STRIKE ENDS WITH ANY DEGREE OF FORCE.

Then turn to extreme left, counting the exact number of turns from right to left end. Turn wheel back one-half number of wheel turns. Mark wheel with respect to steering column so center position may readily be found during adjustment procedures.

Worm Bearing THRUST Adjustment: Refer to Plate 6636 and proceed as follows:

1. Check tightness of cover bolts, see Plate 6636. Loosen lock nut and turn lash adjuster screw (Plate 6637) counter-clockwise a few turns to provide clearance between sector gear and worm ball nut.

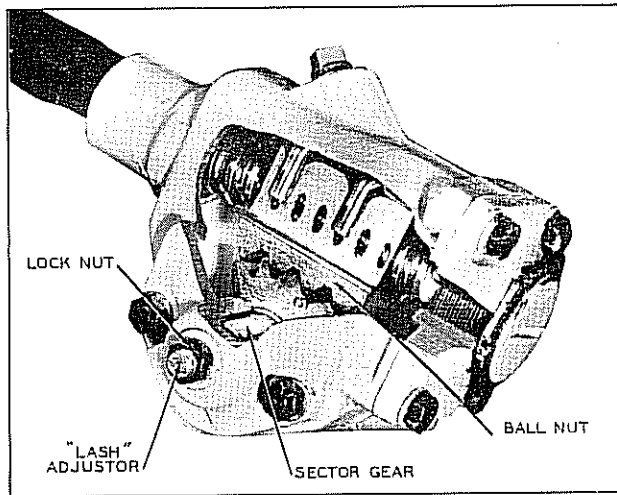

Plate 6637. Steering Gear Lash Adjustment (Sector Gear)

2. Turn steering wheel GENTLY to one extreme end. Turn wheel back one full turn. With spring scale on spoke of wheel, measure pull required to KEEP WHEEL MOVING. Pull on scale should be made at right angles to wheel spoke. If pull is within 1 1/2 to 2 pounds, proceed to lash adjustment in the following paragraphs. If pull is not within 1 1/2 to 2 pounds, adjust worm bearings. The pitman shaft adjustment must be made if worm bearing check is accomplished, or if the worm bearings are adjusted.

3. If it is necessary to adjust the worm bearings, loosen lock nut and then turn worm bearing adjuster nut clockwise until all end play is removed, see Plate 6636. Using spring scale, as directed in Step 2, check pull and readjust as necessary; then tighten lock nut securely.



INDUSTRIAL TRUCK DIVISION



LUBRICATION AND PREVENTIVE MAINTENANCE

Sector Gear Lash Adjustment: Refer to Plate 6637, and proceed as follows:

1. Steering Gear Mechanism must be in straight ahead position as previously explained.

2. Turn lash adjuster screw clockwise to remove all lash between gear teeth. Tighten adjuster screw lock nut. Position spring scale on steering wheel so pull may be made at right angles to wheel spoke.

3. Measure pull while wheel is TURNED THROUGH CENTER POSITION. Readjust if reading is not within 2 1/2 to 3 pounds.

4. Tighten adjuster screw lock nut, check pull again.

5. After adjustments are made, install drag link on pitman arm.

NOTE

IF STEERING LINKAGE ADJUSTMENT IS NECESSARY
DO NOT INSTALL DRAG LINK TO PITMAN ARM.

STEERING LINKAGE ADJUSTMENT

Steering mechanism must be in straight ahead position (refer to Steering gear adjustments for correct procedure) before making the following adjustments.

Pitman Arm should now be in a vertical position. If not, remove pitman arm and reinstall it without moving hand wheel from its centered position.

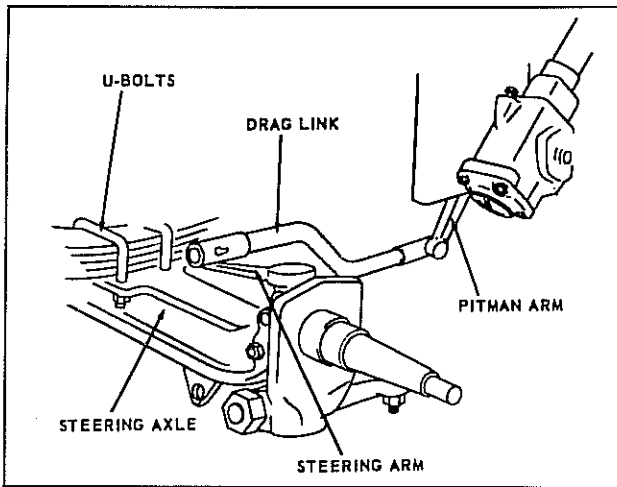

Plate 6274. Steer Linkage Adjustment

Shorten or lengthen Drag Link until it connects with Pitman Arm without moving centered position of Hand Wheel and without moving straight ahead position of Steer Wheels.

Tighten all nuts.

Adjust Turning Radius: The two stop screws, located on the front axle, are for adjusting the turning radius of the tractor. Adjustment is made by loosening the lock nuts and turning the stop screws IN to lengthen turning radius, or OUT to shorten turning radius. When the specified turning radius is obtained, tighten lock nut. Refer to Specifications for specified turning radius.

SUSPENSION. Inspect Spring Shackles, U Bolts and Clips for damage and security of mounting.

LINKAGE. Lubricate all miscellaneous linkage with S.A.E. No. 20 oil.

Tighten all Bolts; Nuts and Cap Screws.

INTAKE AND EXHAUST MANIFOLDS

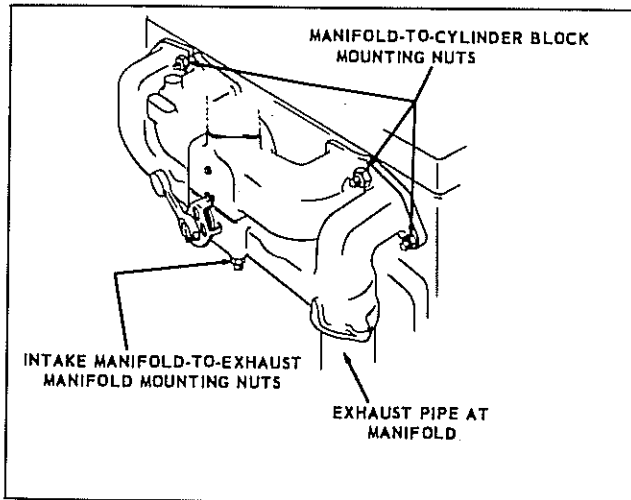

1. Inspect gaskets for leaks and inspect security of manifold nuts.

2. Inspect exhaust pipe and muffler for damage, leakage and security of mountings.

NUTS, BOLTS AND CAP SCREWS. Check security of mounting, tighten as required.

Plate 6269. Intake and Exhaust Manifolds

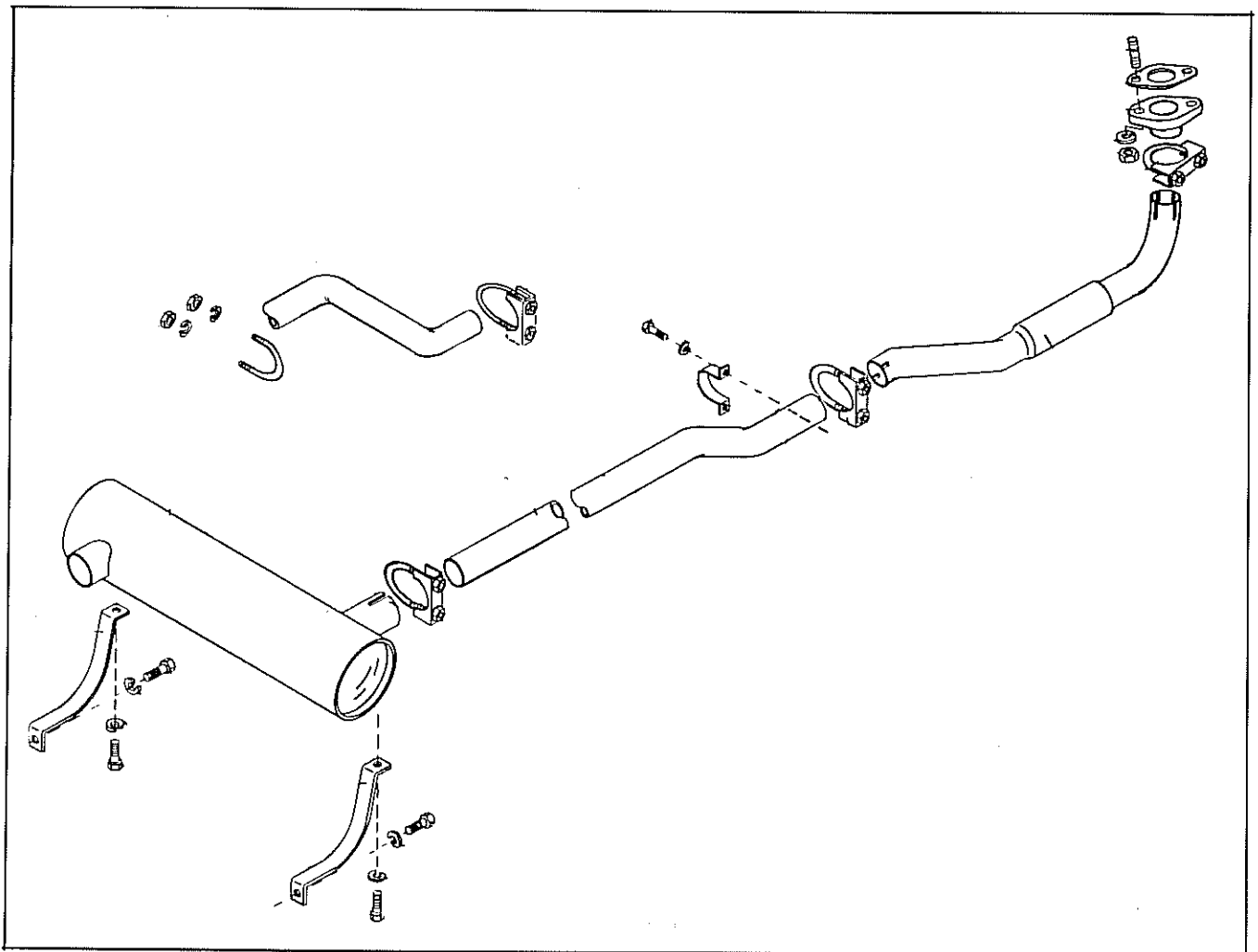

Plate 7720. Typical Muffler and Mounting

LUBRICATION AND PREVENTIVE MAINTENANCE

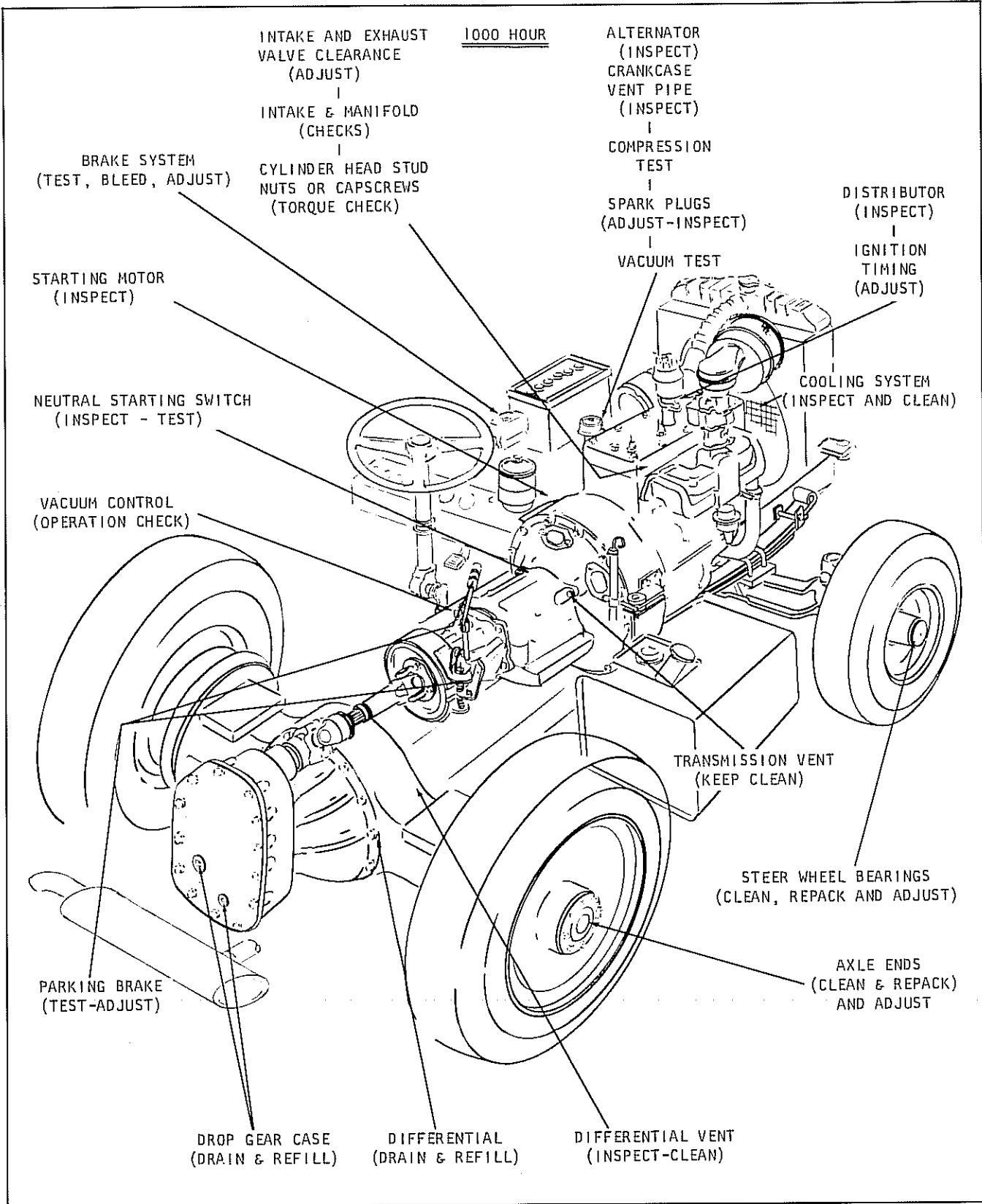

Plate 7736. Lubrication and Preventive Maintenance Illustration

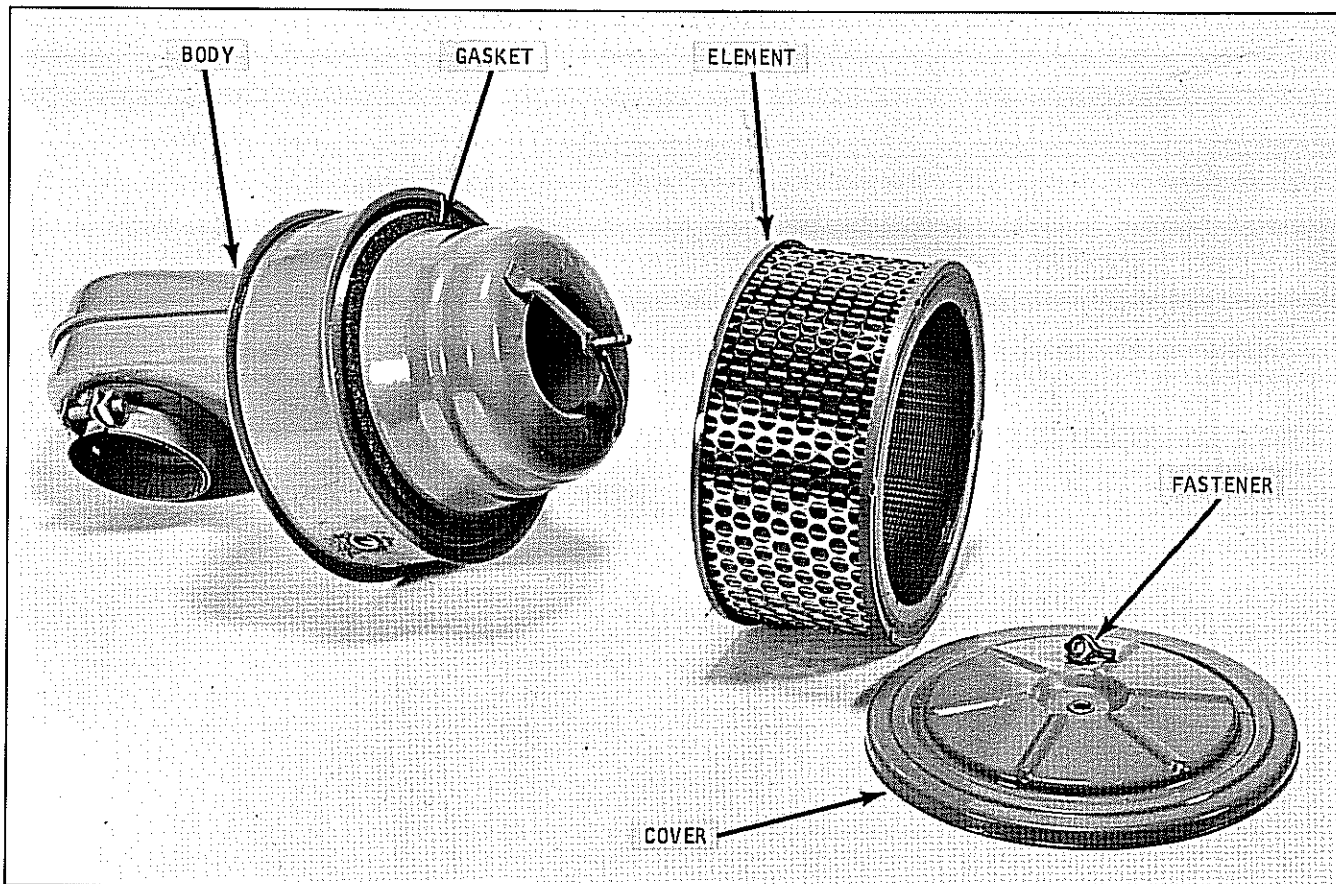

Plate 7428. Air Cleaner Assembly

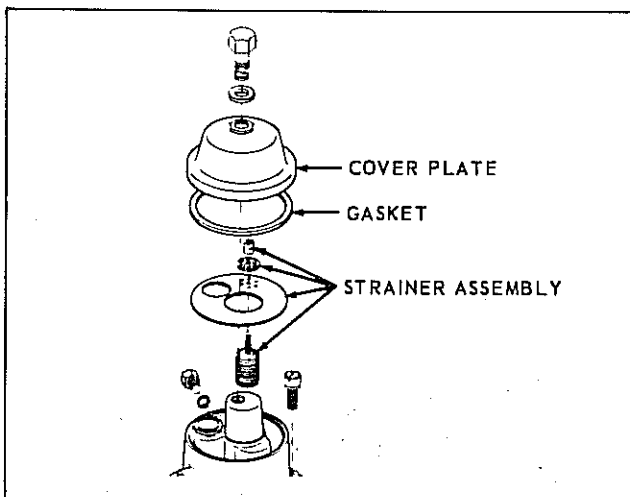

Plate 6279. Fuel Pump Cleaning Strainer Assembly

ENGINE TUNE-UP

Engine tune-up is the orderly and systematic process of checking the engine and accessory equipment to maintain or restore satisfactory engine performance. Engine tune-up must be accomplished semi-annually and more frequently if engine performance indicates the need for these services. Perform engine tune-up as follows:

1. **AIR CLEANER.** Be sure air cleaner has received proper service. Air cleaner must be installed before making engine tune-up.

2. **FUEL PUMP.** Be sure the fuel pump bowl and strainer has been properly serviced and the fuel pump is operating satisfactorily.

3. CYLINDER HEAD STUD NUTS. Check all stud nuts for correct torque, refer to specifications. Check cylinder head gasket for leaks.

C A U T I O N

THE SEQUENCE LISTED IN PLATE 5927. MUST BE FOLLOWED. ALL CYLINDER HEAD CAP SCREWS OR NUTS MUST BE TIGHTENED EVENLY AND TORQUED IN ACCORDANCE WITH LIMITS LISTED IN SPECIFICATIONS.

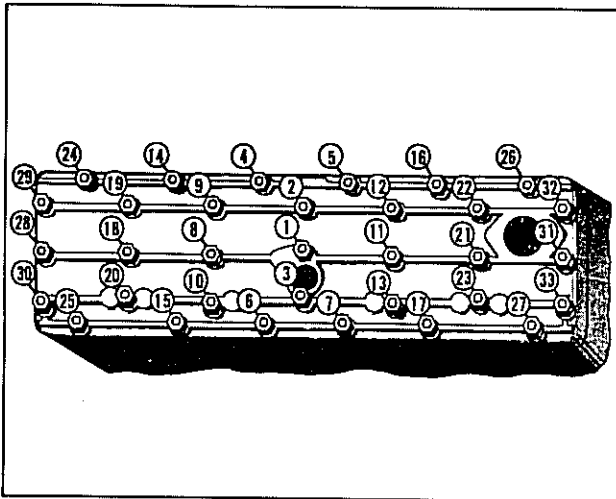

Plate 5927. Cylinder Head Stud Nut Tightening Sequence

4. INTAKE AND EXHAUST MANIFOLDS. Inspect for gasket leaks and security of mounting.

5. CRANKCASE VENTILATION METERING VALVE. The metering valve connected between the intake manifold and valve cover regulates the amount of air which will flow through the crankcase and is controlled by the engine vacuum.

Remove metering valve and disassemble and wash in a Stoddard type cleaning solvent. Before assembling, put a small quantity of very light oil on the metering pin to prevent sticking until its own lubrication is established. The ventilation tube and valve cover should also be cleaned at the same time, particularly if any noticeable amount of sludge accumulation is found.

After installing the metering valve on the engine be sure hose is in good condition and all connections are properly

sealed to prevent unfiltered air from entering the engine.

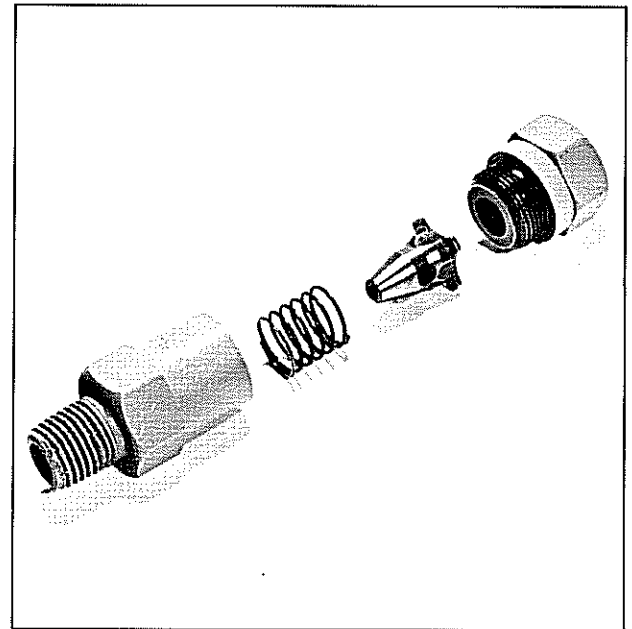

Plate 7034. Crankcase Ventilation Metering Valve

6. INTAKE AND EXHAUST VALVE CLEARANCE ADJUSTMENTS.

a. Remove valve chamber cover mounting screws, and the valve chamber cover gasket.

b. With engine running at idling speed and at normal operating temperature, adjust intake valves as follows:

c. Check for proper 0.014 inch clearance by alternately passing a 0.013 inch and a 0.015 inch flat feeler gauge between head of adjusting screw and valve stem, see Plate 3223 on following page.

d. If a 0.013 inch feeler gauge moves freely back and forth in gap when valve is not being lifted and a 0.015 inch feeler gauge binds, at all times, clearance requires no adjustment.

e. If a 0.013 inch feeler gauge is gripped at all times, the clearance is insufficient.

f. Hold valve lifter with an open end wrench while using a second wrench to turn adjusting screw 1/4 to 1/2 turn clockwise. Repeat clearance check and adjustment, until proper clearance is obtained. The adjustable type valve lifters

have self-locking adjusting screws that require no lock nuts.

g. If 0.015 inch feeler moves freely when valve is not being lifted, the clearance is too great. Hold valve lifter with an open end wrench while using a second wrench to turn valve lifter adjusting screw counterclockwise 1/4 to 1/2 turn. Repeat clearance check and adjustment until proper clearance is obtained.

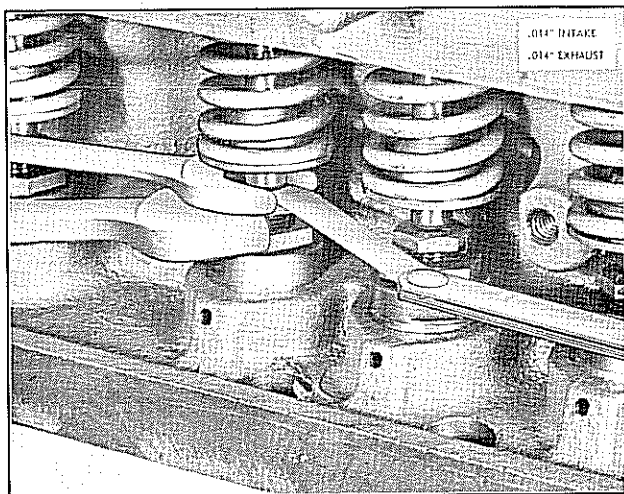

Figure 004a. Adjusting Valve Clearance

h. Repeat clearance check and adjustment on remaining intake valves.

i. With engine running at idling speed and at normal operating temperature, adjust exhaust valve as follows:

j. Check for proper 0.014 inch clearance by alternately passing a 0.013 inch and a 0.015 inch flat feeler gauge between head of adjusting screw and valve stem cap, see Figure 004a.

k. Follow procedure outlined in paragraphs (d) thru (h).

m. Install valve chamber cover using new valve chamber cover gasket and replace cover mounting screws.

N O T E

DO NOT REUSE OLD GASKETS. THEY DO NOT AFFORD A POSITIVE SEAL.

n. Check valve chamber cover gasket for leaks.

7. COMPRESSION TEST

a. Test battery for full charge (specific gravity 1.280 temperature of 24°C (75°F)). If battery is not fully charged, replace with fully charged battery.

b. Start engine and allow it to warm up until normal operating temperature is reached.

c. Turn off ignition.

d. Remove spark plug cables from spark plugs and remove spark plugs from cylinder head. Examine spark plugs for carbon deposits, defective insulation and general serviceability. All carbon or lead deposits must be removed from the insulation shell and electrodes. This can be done on a sand blast cleaner. Carbon deposits should be removed from the plug threads with a stiff brush. After cleaning, inspect plugs carefully for cracked or broken insulator, badly pitted electrodes or other signs of failure.

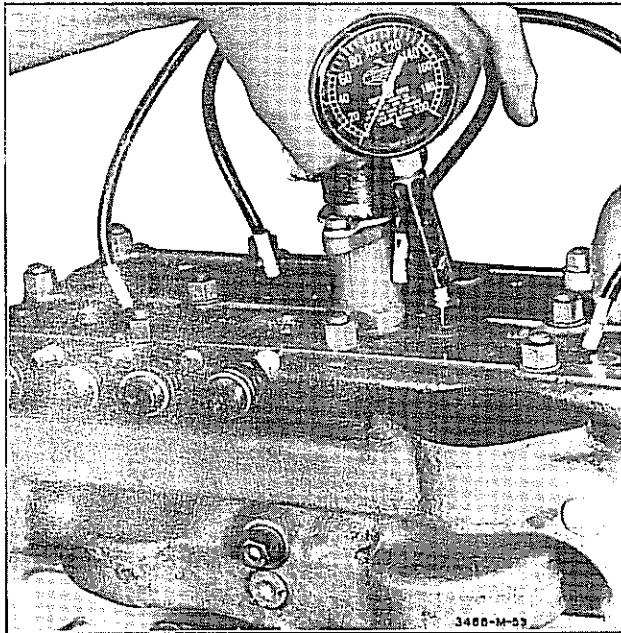

Plate 3486. Compression Test

e. With all plugs removed, install compression gauge in front spark plug port. Operate starting motor until maximum reading on gauge is obtained, see Plate 3486. Record gauge reading. Repeat this operation on each remaining cylinder.

f. If readings are reasonably high (110 to 120) pounds and the readings do not vary more than about 10 pounds between cylinders, compression may be considered normal. Excessively low readings or readings that vary more than 10 pounds between cylinders indicate internal trouble to be corrected after further examination and testing.

g. Set the spark plug gap as specified, by bending side electrode only. The gap should be checked with a wire feeler gauge rather than a flat type gauge as it is better suited for this purpose.

h. Spark Plug Specifications:

Standard Type - .025" Gap
Resistor Type - .035" Gap

i. Replace spark plugs using new gaskets. Always replace spark plug gasket whenever a spark plug is removed from the engine. Before installing plugs, be sure that the spark plug seat in the cylinder head is clean and free from obstructions. The spark plug should be screwed into cylinder head (using a socket of proper size) sufficiently tight to fully compress the gasket. This is most important as a large percentage of troubles due to overheated spark plugs are caused by plugs being too loose in the cylinder head. Conversely, excessive tightening may change the gap between the electrodes or crack the insulator.

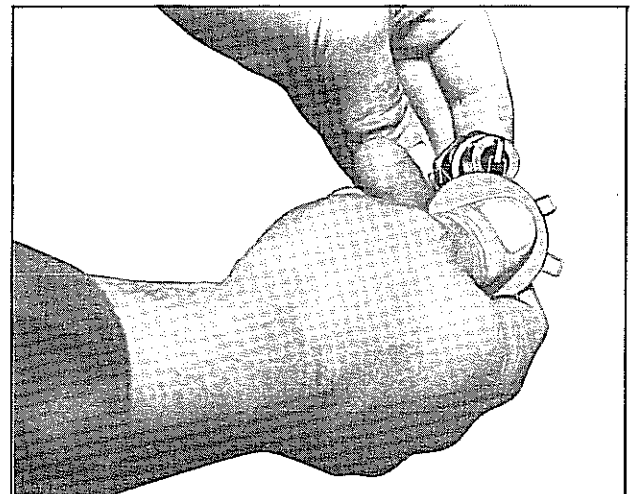

Plate 3278. Check Spark Plug Gap

LUBRICATION AND PREVENTIVE MAINTENANCE

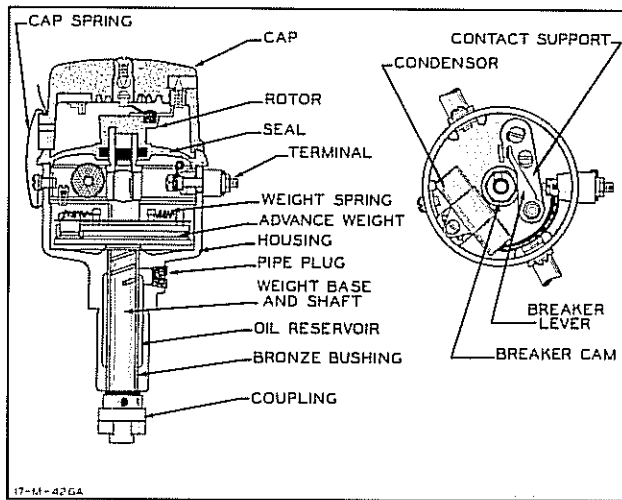

Plate 3409. Distributor

8. DISTRIBUTOR

Inspection: Remove distributor cap (without removing wires). Wipe cap with a clean cloth. Examine rotor and cap for chips, cracks, corroded terminals, carbon runners (paths which will allow high-tension leakage to ground) or if the vertical faces of the inserts are burned -- install a new cap and rotor, as this is due to the rotor being too short.

Check the centrifugal advance mechanism for "freeness" by turning the breaker cam in the direction of rotation and then releasing it. The advance springs should return the cam to its original position without sticking.

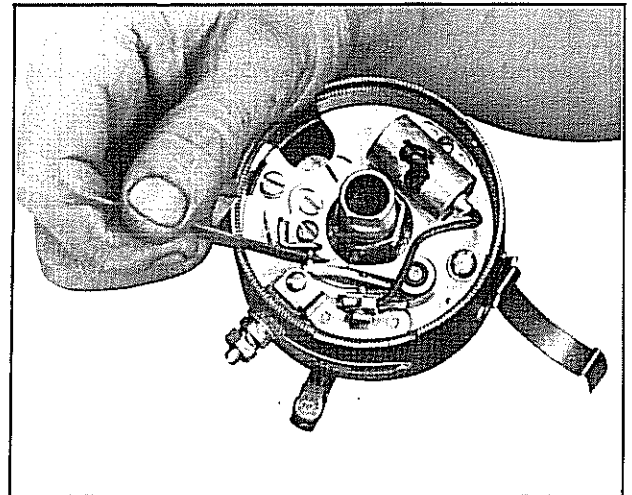

Plate 3364. File Contact Points

Inspect breaker points. If points are pitted, burned or worn to an unserviceable condition, install a new set of points.

The normal color of contact points should be a light gray. If the contact point surfaces are black, it is usually caused by oil vapor, or grease from the cam. If they are blue, the cause is usually excessive heating due to improper alignment, high resistance or open condenser circuit.

Badly pitted points may be caused by a defective or improper condenser capacity.

If the condenser capacity is too high, the crater (depression) will form in the positive contact. If the condenser capacity is too low, the crater will form in the negative contact, see Plate 5933.

For a temporary repair, dress the contact points with a few EVEN strokes using a clean fine-cut contact file. DO NOT ATTEMPT TO REMOVE ALL ROUGHNESS OR DRESS THE POINT SURFACES DOWN SMOOTH. See Plate 3364.

CAUTION

NEVER USE EMERY CLOTH OR SANDPAPER TO CLEAN POINTS AS PARTICLES WILL EMBED IN THE POINTS AND CAUSE ARCING AND RAPID BURNING.

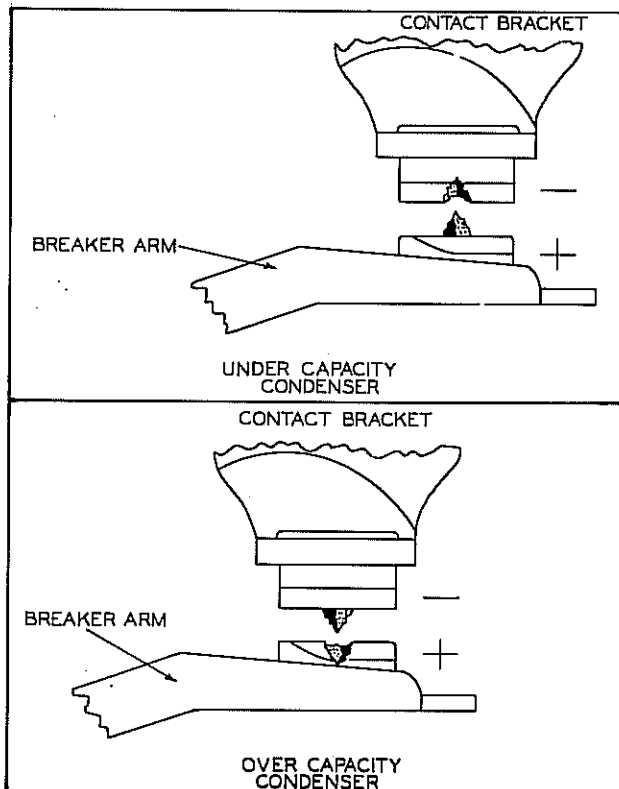
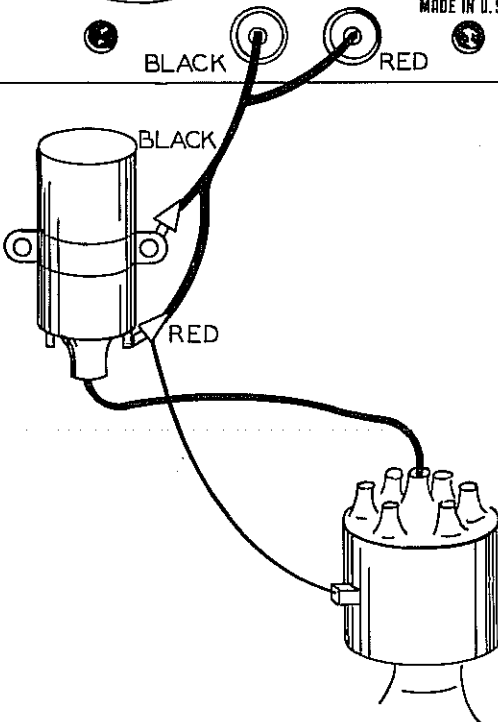
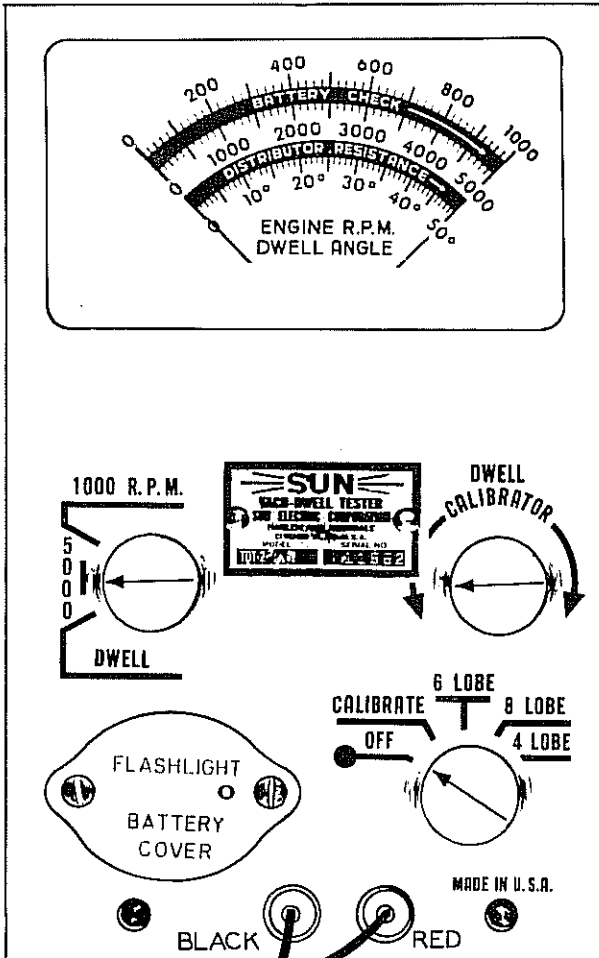

Plate 5933. Breaker Points



MEASURING ENGINE SPEED

1. Connect the test leads as shown.
2. Turn switch to the LOBE position corresponding to the number of cylinders.
3. Turn the other switch to the 1000 rpm position for all idle and low speed testing. Use the 5000 rpm position for all speeds over 1000 rpm.

DISTRIBUTOR RESISTANCE TEST

1. With test leads disconnected, turn switches to DWELL and CALIBRATE positions and adjust dwell calibrator until meter reads on the SET LINE.
2. Connect test leads as shown.
3. Turn ignition switch ON with engine stopped. If distributor resistance is not excessive, meter will read in the black bar marked DISTRIBUTOR RESISTANCE.

If meter does read within black bar, readjust dwell calibrator until meter again reads on the SET LINE before making the following tests.

If meter does not read within black bar, excessive resistance is indicated. To locate excessive resistance, trace the primary circuit through the distributor with the red test lead until point of high resistance is located. Excessive resistance must be eliminated and the dwell calibrator adjusted until the meter again reads on the SET LINE before proceeding with the following tests.

DWELL AND DWELL VARIATION TESTS

1. Turn switch to the proper LOBE position.
2. Operate engine at idle speed and note reading on dwell scale of meter. Refer to specifications for proper dwell.
3. Turn tachometer switch to the 5000 rpm position and increase speed to 1500 rpm.
4. Turn switch back to the DWELL position and again note dwell reading. Slowly reduce speed to idle while watching meter. Dwell should not change more than 3 degrees in either case.

LUBRICATION AND PREVENTIVE MAINTENANCE

Contact Point Adjustment: The point opening of new points can be checked with a wire feeler gauge, but the use of a feeler gauge on older, rough points is not recommended, since accurate gauging cannot be done on such points. The gauge measures between high spots on the points instead of the true point opening. Point opening of used points can be checked with a Dwell Angle Meter. A meter of this type indicates the cam or contact angle. This angle is the number of degrees that the breaker cam rotates from the time the points close until they open again. The cam angle increases as the point opening decreases and it is reduced as the point opening is increased. Manufactures of this type equipment furnish complete instructions as to their use.

NOTE

REFER TO SPECIFICATIONS FOR DWELL ANGLE AND CONTACT POINT OPENING.

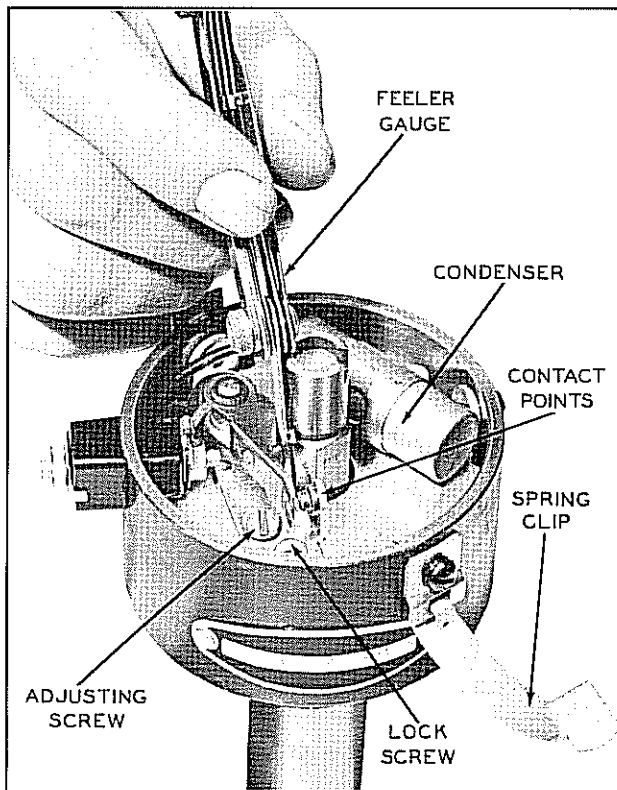

Plate 6266. Contact Point Adjustment

To check point opening with a feeler gauge, insert a wire feeler gauge of proper size between the contact points. **MAKE CERTAIN THAT THE BUMPER BLOCK ON THE MOVABLE CONTACT IS AT THE HIGH POINT ON THE CAM.** If adjustment is necessary, loosen

the lock screw and turn the eccentric screw until the proper clearance is obtained. Retighten locking screw and recheck point gap. See Plate 6266.

9. IGNITION TIMING

If the engine is out of time, the following procedure should be followed:

- a. Remove No. 1 spark plug which is the one nearest the radiator.
- b. Press thumb over hole left vacant by removal of the spark plug.
- c. With thumb pressed over hole, Plate 3471, turn engine over slowly with the starter until air is being forced up around the thumb.
- d. Stop turning engine over at this point for it means that No. 1 piston is on the compression stroke and it is approaching top dead center.
- e. Flash a light into the timing hole and continue to turn engine over slowly until top dead center marking on flywheel appears in timing hole, Plate 3471
- f. The pointer Plate 3471 should be centered on the top dead center marking.
- g. With breaker points set a proper gap, loosen distributor clamp plate screw and rotate distributor body until the contact points just start to open. This may be more accurately checked by means of a test lamp connected between the distributor primary lead and a ground. When points are closed the light will be "OFF" and as soon as the points break the light will go "ON". Tighten clamp plate screws before starting engine.

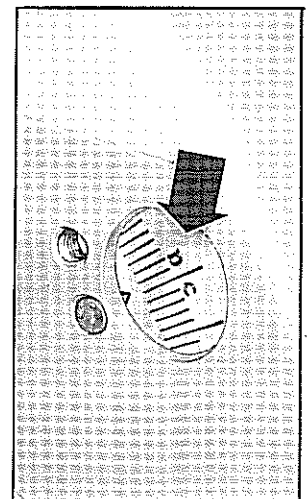
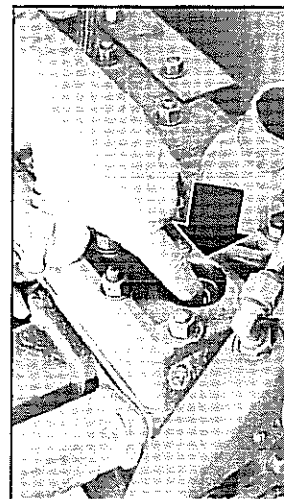

Plate 3471. Ignition Timing

10. VACUUM TEST

Before making vacuum test, make certain cylinder head is securely tightened and that cylinder head gasket is not leaking. Air cleaner must be installed and must be clean to perform vacuum test. Manifold stud nuts must be tight and there must not be any leakage at gasket.

a. Remove pipe plug from intake manifold. Attach vacuum gauge in pipe plug opening.

b. Start engine and allow it to warm up to normal operating temperature.

c. Check Vacuum Gauge. Reading should be 18 to 22 inches and needle should hold steady flutter. If needle does not indicate desired reading, an idle fuel adjustment should be made to obtain highest steady reading.

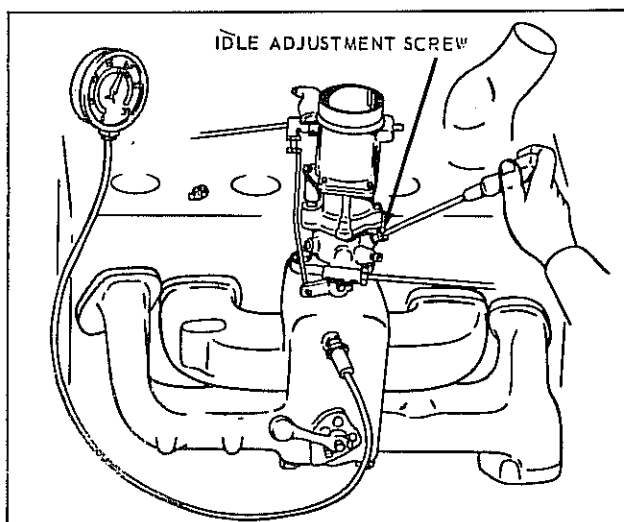

Plate 6283. Vacuum Test

Idle Fuel Adjustment: The carburetor is controlled by the idle adjustment screw that regulates the fuel-air mixture. Turning the screw clockwise, towards the seat, cuts off air increasing the suction on the idle jet and making the mixture richer. Turning the idle adjusting screw counterclockwise, or away from seat, allows more air to be mixed with the fuel making a leaner mixture for idling.

Turn the screw until highest vacuum reading is obtained. If vacuum gauge needle cannot be held steady after these adjustments have been made, report condition to designated person in authority.

If a gauge is not used, set the screw to a range at which engine idles its smoothest.

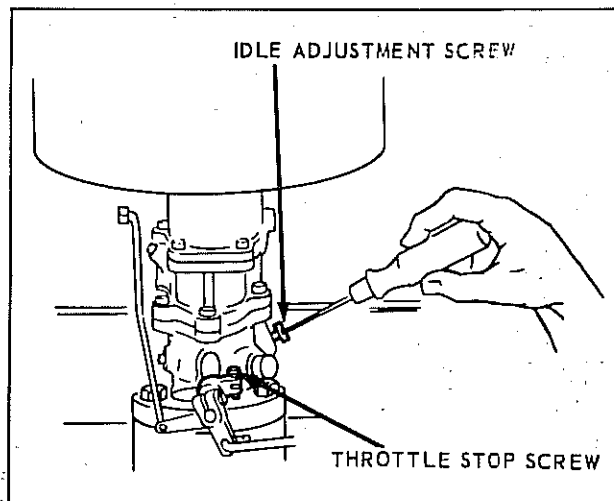

Plate 6282. Adjusting Carburetor

Idle Speed Adjustment: A stop screw controls action of the throttle valve. Turn screw clockwise for faster idle speed, or counterclockwise for slower idle speed. This adjustment should be made with a tachometer. Idling speed should be set for 450 to 500 revolutions per minute. Reset idle mixture screw if necessary, after throttle adjustment has been made.

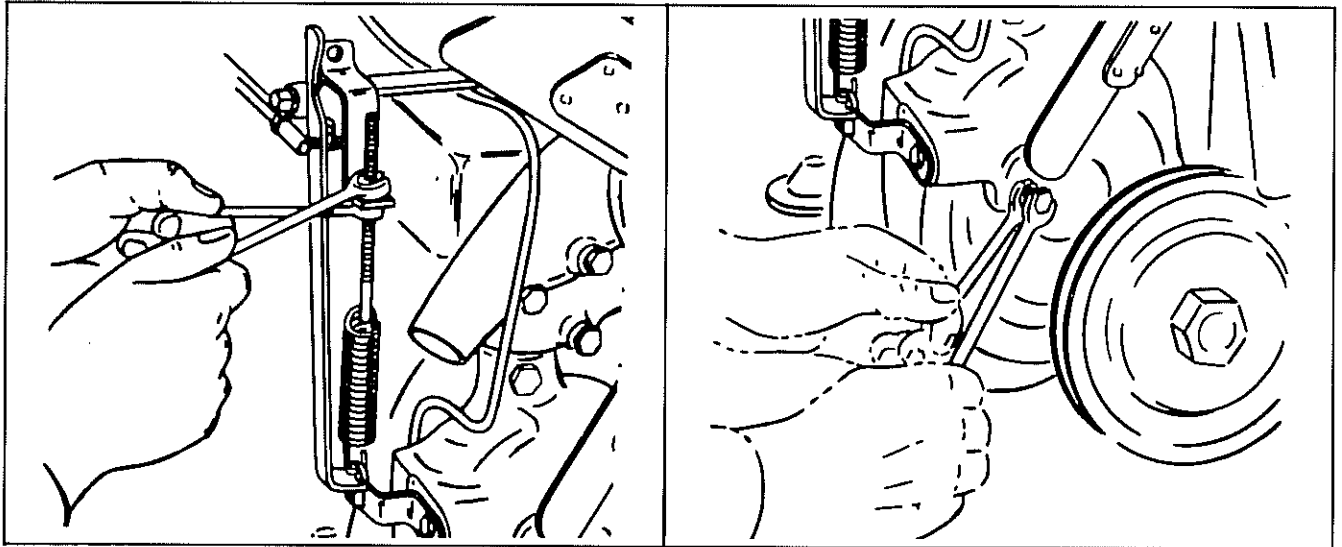

Plate 6276. Governor Speed Control (left), Surge (right)

GOVERNOR. The purpose of the governor is to limit the top speed of the engine to a desired R.P.M. The governor is located on the camshaft gear behind the timing gear cover. It consists of a ball bearing assembly engaged to the governor cup and shaft assembly which acts on the governor arm. The function of the governor is based on action of two forces working against each other. One is the centrifugal force exerted on the ball bearing assembly when engine is running, tending to close the throttle. The other force consists of two adjustable springs, one located inside the timing gear cover, and the other attached to the external part of the governor arm. Both tend to open the throttle by counteracting the pressure of the cup against the governor arm. To set governor properly it is necessary to use an electric tachometer. Proceed with the governor adjustment in this manner:

a. Connect tachometer to engine, start engine and warm up to normal temperature.

b. To decrease engine speed, loosen speed control nut which decreases tension on spring. To increase speed, tighten speed control nut.

c. If engine should surge or not maintain steady top speed, then adjustment for the surge can be made at the governor spring bumper screw in the gear cover by loosening the lock nut and turning bumper screw to the right until surging ceases and engine runs steady at top speed. Tighten lock nut securely after adjustment. It may be necessary to readjust top speed after making surge adjustment.



STARTING MOTOR

1. Remove end plate (or Brush Cover) from starter. Use a wire hook to lift a brush spring and remove brush from holder. Compare brush size with that of a new brush. If brush is worn beyond half the original size, or if brushes are jammed, chipped, or broken they must be replaced.

CAUTION

NEVER ALLOW SPRING TO SNAP DOWN ON BRUSHES.

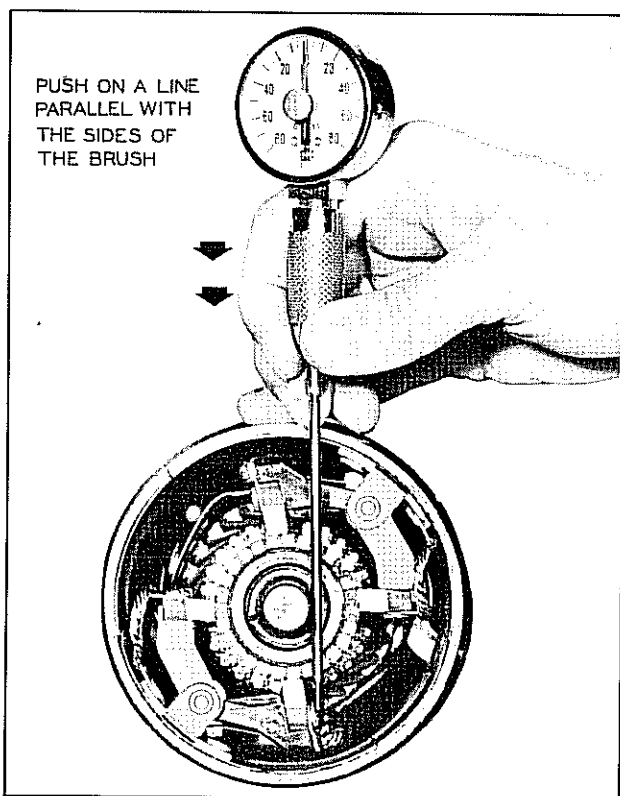

Plate 6449 Checking Brush Spring Tension

2. Check for Brush Spring Tension, refer to Specifications. Refer to the following procedures for checking spring tension.

Measuring Brush Spring Tension - Reaction Type Brushes. Hook the scale under the brush spring near the end and push or pull on a line parallel to the sides of the brush. To assist in telling the exact instant that the pressure is relieved, a small strip of paper can be placed under the brush. Pull slightly on the paper and the paper will slip out at the correct instant for reading the spring scale.

Measuring Spring Tension - Swinging Type Brushes: Hook the spring scale under the brush screw tight

against the brush and push or pull on a line parallel to the sides of the brush. Take the reading just as the brush leaves the commutator. Pulling slightly on a strip of paper which has been placed under the brush will indicate when the brush leaves the commutator and the correct instant for reading the spring scale.

3. If commutator is glazed or dirty, clean with a strip of No. 00 sandpaper. Blow out all dirt and grit with compressed air.

CAUTION

DO NOT USE EMERY CLOTH TO CLEAN COMMUTATOR.

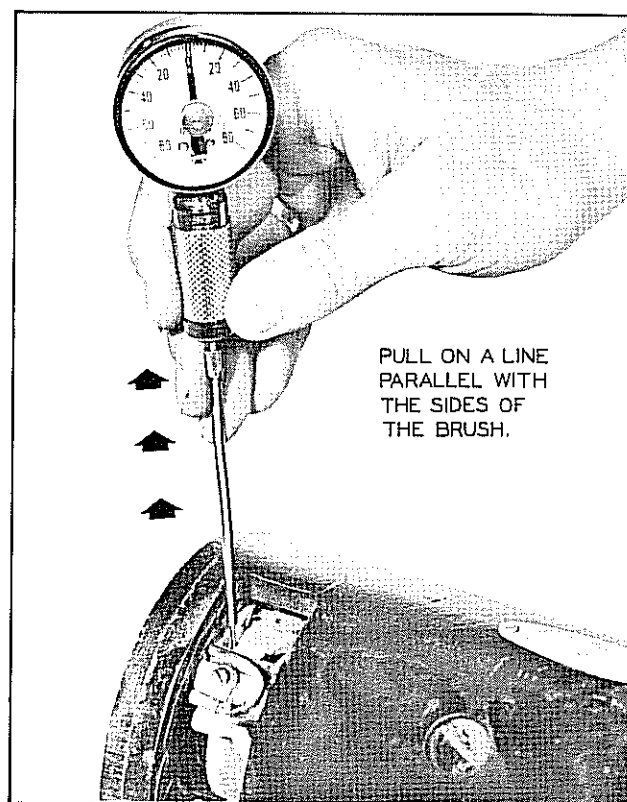

Plate 6450. Checking Brush Spring Tension

Condition Test: Use one of the two following methods to determine whether the starting motor should be removed from the engine for inspection, service or replacement.

1. First Method: Operate the starting motor by disconnecting the battery cable from the solenoid switch and holding the cable terminal firmly against the starting motor terminal, using a battery known to be fully charged and in good condition. To do this it will be necessary to remove the solenoid switch.

2. If the motor reacts correctly, and the drive mechanism engages and disengages each time the starting motor is operated, the starting motor is in good condition.

3. If motor does not react properly, it must be removed for inspection or replacement.

4. Second Method: Using a voltmeter and a battery (fully charged) that is in good condition, connect positive lead of test voltmeter to positive terminal of battery and negative lead of voltmeter to negative (grounded) terminal of battery. Record voltmeter reading. Now pull high-tension wire from ignition coil so engine will not start when starter is engaged. Connect positive lead of test voltmeter to ground and negative lead of test voltmeter to starter switch terminal. Turn ignition switch to start position and note voltmeter reading. Compare this reading with the previously recorded reading. If the voltage drop is more than 4 volts, or if the second reading is below 8 volts, the starting motor should be removed from the engine for further testing and repair, or replacement.

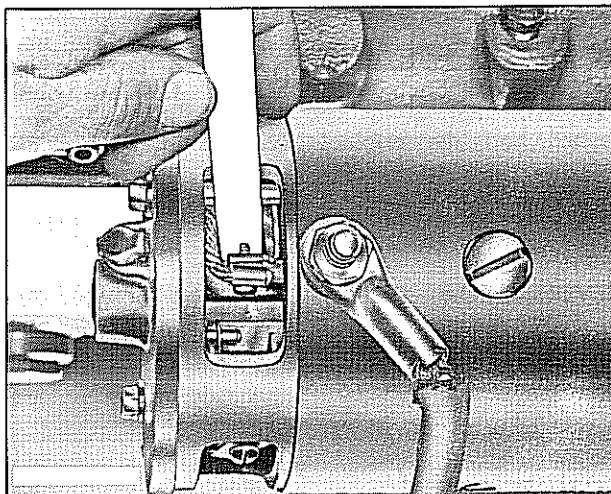

Plate 3436. Seating Brushes

NOTE

BLOW OUT ABRASIVE PARTICLES AFTER SEATING BRUSHES.



INDUSTRIAL TRUCK DIVISION



LUBRICATION AND PREVENTIVE MAINTENANCE

ALTERNATOR

IMPORTANT ---- Since the alternator and regulator are designed for use on only one polarity system, the following precautions must be observed when working on the charging circuit. Failure to observe these precautions will result in serious damage to the electrical equipment.

1. When installing a battery, always make absolutely sure the ground polarity of the battery and the ground polarity of the alternator are the same.

2. When connecting a booster battery, make certain to connect the negative battery terminals together and the positive battery terminals together.

3. When connecting a charger to the battery, connect the charger positive lead to the battery positive terminal and the charger negative lead to the battery negative terminal.

4. Never operate the alternator on open circuit. Make absolutely certain all connections in the circuit are secure.

5. Do not short across or ground any of the terminals on the alternator or regulator.

6. Do not attempt to polarize the alternator.

INSPECTION — The terminals should be inspected for corrosion and loose connections, and the wiring for frayed insulation. Check the mounting bolts for tightness, and the belt for alignment, proper tension and wear. Belt tension should be inspected and adjusted if necessary every 100 operating hours and adjusted per the procedures listed on page 100H 203.

After extended periods of operation, or at time of engine overhaul, the alternator may be removed from the vehicle for a thorough inspection and cleaning of all parts. The alternator requires no other service other than the previously mentioned inspection. When it becomes necessary to perform tests and internal inspection of the alternator, see your nearest authorized Clark Equipment Dealer.

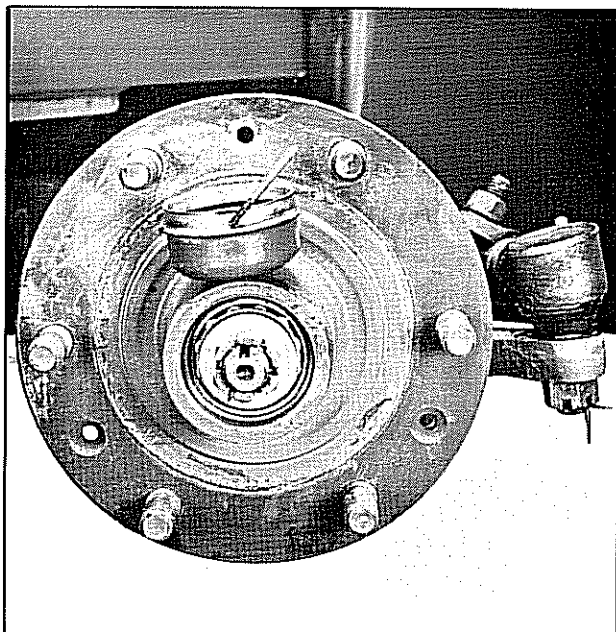

Plate 7065. Wheel Bearings

STEERING WHEEL BEARINGS

Adjustment:

1. Raise rear of machine so that tires clear the ground.
2. Inspect adjustment of bearings by gripping top and bottom of tire, chuck tire "in" and "out" to determine looseness or wobble. Now grip front and rear side of tire, chuck tire "in" and "out" to determine looseness or wobble.

NOTE

BEFORE MAKING WHEEL BEARING ADJUSTMENTS, BE SURE PLAY (LOOSENESS OR WOBBLE) IS IN THE WHEEL BEARINGS AND NOT IN THE KING PINS.

NOTE

IF WHEEL BEARINGS NEED ADJUSTING, CLEAN AND REPACK BEARINGS BEFORE MAKING ADJUSTMENTS. REFER TO LUBRICATION PARAGRAPH.

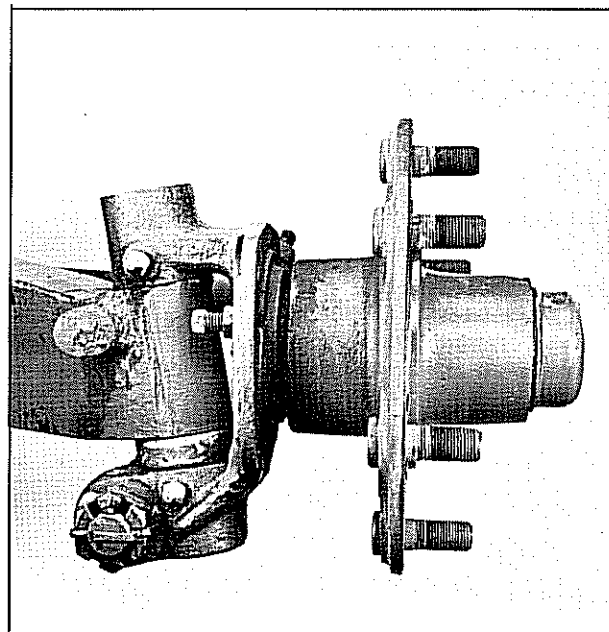

Plate 7066. Wheel Hub and Spindle

3. If looseness or wobble is in the wheel bearings, remove hub cap and spindle cotter pin, see plate 7065. Tighten nut with a 12" wrench, and at the same time rotate the wheel in one direction and then in the other until there is a slight bind to be sure all bearing surfaces are in contact. Then back off the nut 1/6 to 1/4 turn allowing the wheel to rotate freely. Secure nut at this position with a new cotter pin and replace hub cap.

Lubrication:

1. Remove wheels after 1000 hours or every six months of operation. Clean bearings and repack with medium bodied high temperature wheel bearing grease.
2. Install wheels and adjust wheel bearings as previously described.



.....

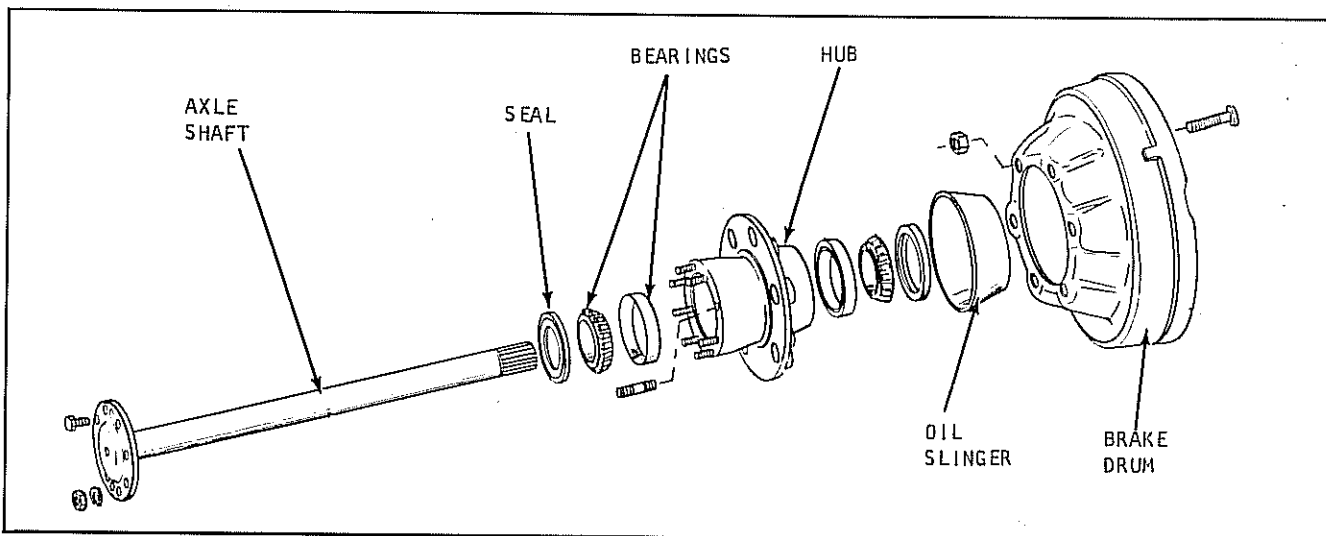

Plate 7102. Axle Shaft and Hub Assembly

CLEAN AND REPACK DRIVE WHEEL BEARINGS

Every 1000 operating hours remove and repack the drive wheel bearings with AMOCO Lithuim multipurpose grease, Shell Alvania EP #1 or equivalent.

1. Raise the drive wheels far enough to clear the floor and place heavy blocking under the machine frame so it cannot accidentally become lowered. Deflate the tires and remove the wheels from the hub assembly.

2. Remove the screws that retain the axle shaft to the hub. By using jack screws in the holes provided in the axle flange, the axle may be pulled.

3. Unclinch the tube nut lock and remove the outer tube nut, nut lock and inner tube nut.

4. The hub and drum assembly may now be removed from the axle tube.

5. Remove the brake drum oil slinger, inner and outer seals from the hub and lift out the bearing cones.

6. Clean the hub assembly and bearings in separate containers using a Stoddard type cleaning solvent. After all solidified particles of lubricant are removed from the bearings blow dry with compressed air. Direct air stream across bearings to prevent spinning. Slowly rotate bearing by hand to facilitate drying. Inspect bearings and races carefully to

determine if they are in good condition and suitable for further service. Dry the hub assembly with compressed air.

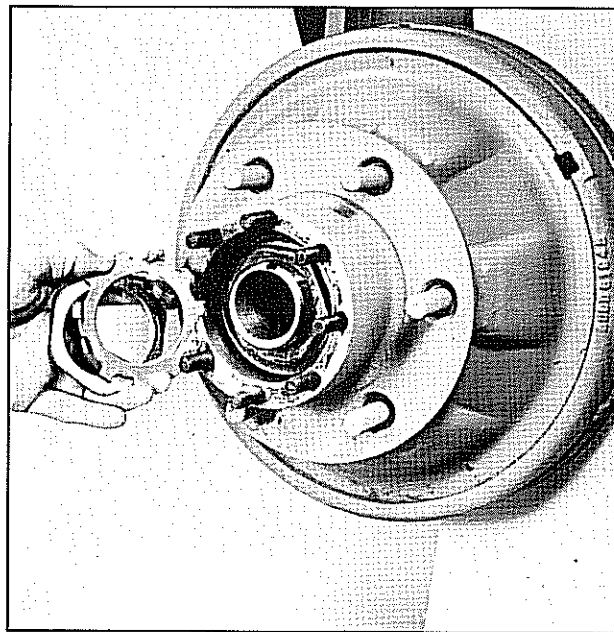

Plate 7103. Axle Tube Nuts and Nut Lock

7. Repack bearing cones with the type grease previously described and install in hub assembly. If there is any doubt about the serviceability of the bearing seals it is more economical to install new ones to prevent a premature overhaul to replace these parts at a future time. Care should be taken when installing the hub over the axle tube to prevent damage to the seals.



INDUSTRIAL TRUCK DIVISION



LUBRICATION AND PREVENTIVE MAINTENANCE

Cutting, scratching or curling under the seal lip seriously impairs efficiency.

8. After hub has been installed on the axle tube replace inner tube nut and tighten until drag is felt when turning the hub. (Be sure brake shoes are not causing drag). Back off the nut slightly until the hub turns free and install nut lock, outer tube nut and tighten. Clinch nut lock to retain nuts in this position.

9. Coat the axle shaft flange to hub mating surface with #2 Permatex.

Insert axle shaft in tube and rotate slowly until splines on shaft are in registry with the differential side gears. Push shaft in and install the retaining screws and tighten to 52-57 ft. pounds torque.

10. Install wheels on hub and inflate tires to proper pressure. Lower machine to floor.

BRAKE BLEEDING PROCEDURE

Proper operation of the hydraulic brake system requires a solid column of fluid without air bubbles at all points in the pressure system. Under certain conditions it becomes necessary to bleed

fluid from the system in order to expel air bubbles which have become mixed with the fluid. The necessity of bleeding is indicated by a soft or spongy pedal, or at any time a brake line is removed (or broken) the system must be bled.

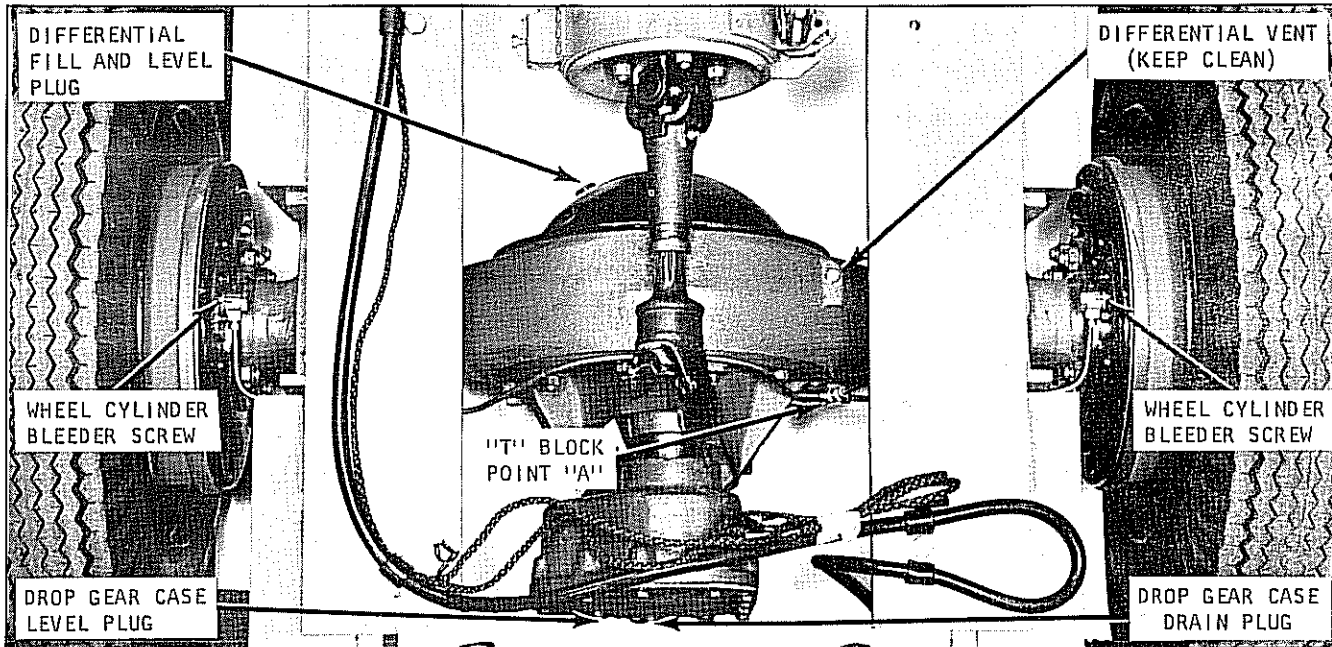

Plate 7435. Bleeding Brake System

Step 1. Raise the drive wheels far enough to clear the floor and place heavy blocking under the machine frame so it cannot accidentally become lowered. Deflate the tires and remove the wheels from the hub assembly.

NOTE

DEFLATE TIRES BEFORE REMOVING DRIVE WHEELS FROM MACHINE.

Step 2. Check the brake pedal free travel (see specifications). Clean dirt from around the filler cap of the master cylinder reservoir. Brake fluid should be within 1/4" of the top. With filler cap off the master cylinder, depress and release brake pedal. A small displacement of fluid should be noticed in the cylinder reservoir. If this happens, the brake pedal (upon being released) is returning the master cylinder piston to its normal position to open a master cylinder port. This port must be open. If fluid does

not return to the reservoir (when releasing brake pedal), this indicates improper pedal free travel and a pedal adjustment is required.

Step 3. Be sure the master cylinder reservoir is filled.

Step 4. Loosen line connection at highest position on "T" block point "A" depress brake pedal slowly and hold allowing fluid and air to escape. Tighten fitting at this point, then release brake pedal. Repeat procedure until fluid is free of air bubbles.

Step 5. Install a bleeder hose on one of the wheel cylinder bleeder screws and submerge the unattached end of the hose in a clean transparent jar containing several inches of brake fluid. **NOTE: DURING BLEEDING OF THE WHEEL CYLINDERS THE JAR SHOULD BE ELEVATED TO A POSITION HIGHER THAN THE BLEEDER SCREWS MAKING SURE THAT THE END OF THE HOSE REMAINS SUBMERGED IN THE FLUID AT ALL TIMES.**



INDUSTRIAL TRUCK DIVISION



LUBRICATION AND PREVENTIVE MAINTENANCE

Loosen bleeder screw and slowly push brake pedal to the floorboard and hold pedal in this position until bleeder screw is retightened. Repeat this operation until all air bubbles disappear and clear fluid is being pumped into the jar.

Step 6. Install bleeder hose on the remaining bleeder screw and proceed as in step five. After all bleeding has been completed, recheck fluid level in master cylinder. Fill to within 1/4 inch of the top with S.A.E. 70 R3 brake fluid. Replace master cylinder cap.

Step 7. Replace drive wheels. Inflate tires. Remove blocking and lower machine to floor.

NOTE

REMEMBER THAT THE BRAKE PEDAL SHOULD BE DEPRESSED SLOWLY AND HELD TO THE FLOORBOARD UNTIL THE LINE CONNECTIONS OR BLEEDER SCREWS ARE SECURELY TIGHTEND. THIS PREVENTS THE POSSIBILITY OF AIR BEING DRAWN INTO THE SYSTEM DURING THE BLEEDING OPERATION. CHECK MASTER CYLINDER RESERVOIR LEVEL PERIODICALLY DURING MANUAL BLEEDING AND FILL TO WITHIN 1/4 INCH OF THE TOP AS REQUIRED.

MINOR BRAKE ADJUSTMENTS

When drums are hot, allow to cool, then proceed as follows:

- a. Adjust brake pedal free play to 1/4 to 1/2 inch.
- b. Raise tractor until drive wheel tires clear floor. Be sure tractor is properly supported and blocked.

C A U T I O N

PLACE BLOCKING UNDERNEATH AXLE FOR SAFETY.

- c. Remove rubber seal from backing plate.
- d. Insert screw driver in backing plate slot, engaging the star wheel adjuster.
- e. Using slot edge as a fulcrum, move screwdriver handle toward axle to rotate star wheel.
- f. Rotate star wheel adjuster until brake lining drags on drum.
- g. Back off star wheel adjustment fourteen notches. This setting should release drag and provide sufficient shoe working clearance.
- h. Repeat this operation on the opposite drive wheel.
- i. Remove blocking, lower vehicle to floor. Test brakes.

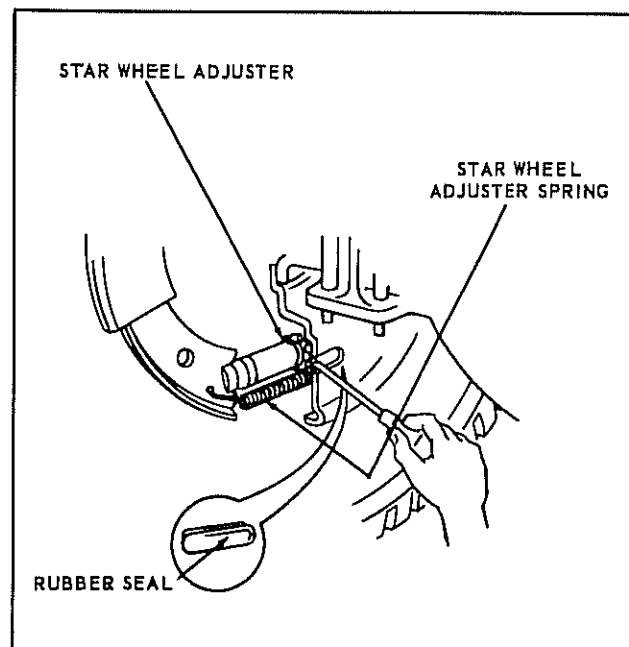

.Plate 6278. Minor Brake Adjustment

HAND BRAKE ADJUSTMENT

The brake is located on the drive shaft between the front drive axle and transmission see Plate 4963. The brake has two adjustments. A minor adjustment may be made at the Actuating Lever located in the driver's compartment. If necessary, a major adjustment may be made at the brake assembly. Brake adjustments are made as follows:

1. Minor Adjustment: Rotate knob on top of the hand brake lever clockwise to increase tension, or counterclockwise to loosen tension. Adjustment should be made with hand lever in fully released position, then test adjustment by applying (pivoting) lever to set brake. See Plate 6505.

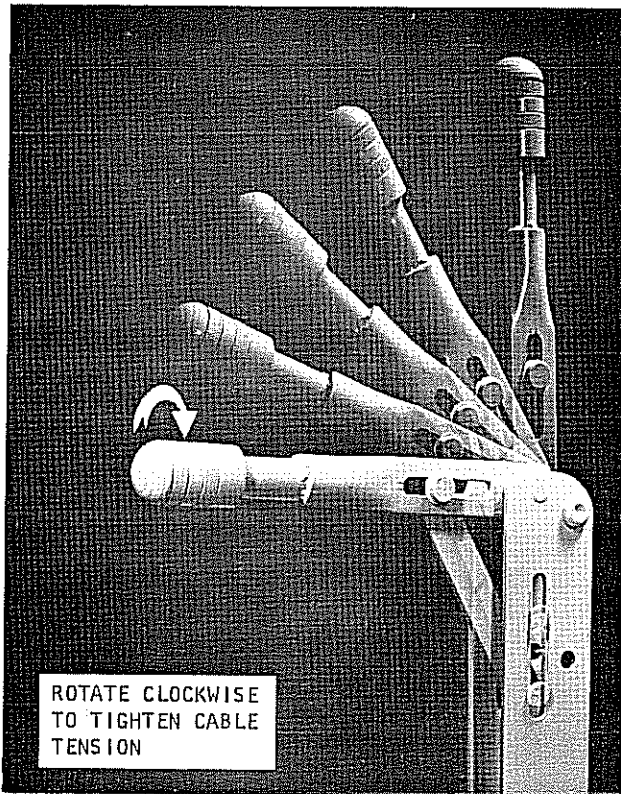

Plate 6505. Hand Brake (Actuating) Lever

2. Major Adjustment: If a major adjustment is necessary to provide proper brake lever release travel and also to provide brake tension, proceed as follows:

a. Set hand brake lever in fully released position and turn knob adjustment counterclockwise as far as possible. See Plate 6505.

b. Turn brake band anchor clip bolt until feeler gauge placed between lining and drum indicates a 0.010 to 0.015 inch clearance. See Plate 6291.

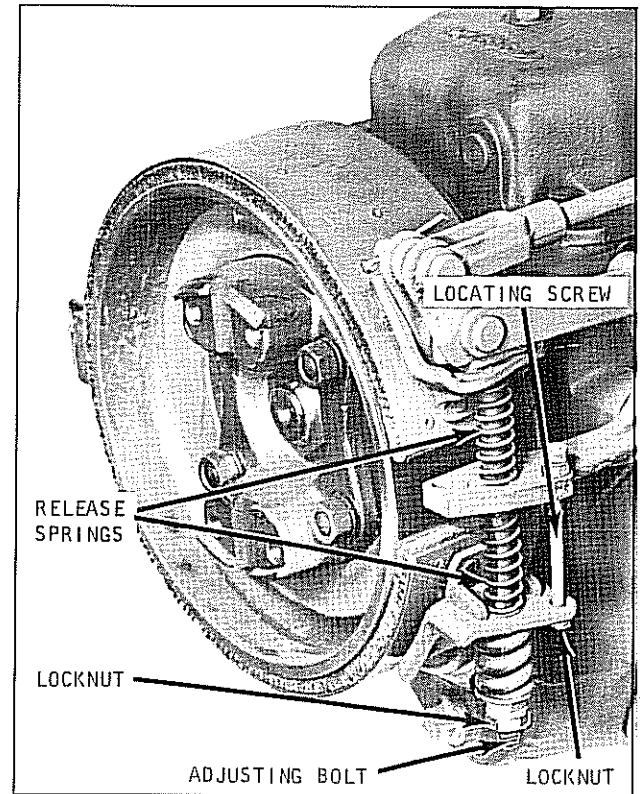

Plate 7447. Hand Brake Adjustments

c. Loosen lock nut and tighten screw until feeler gauge placed between lower end of lining and brake drum indicates a 0.020 inch clearance. Tighten lock nut when this clearance is obtained. See Plate 6290.

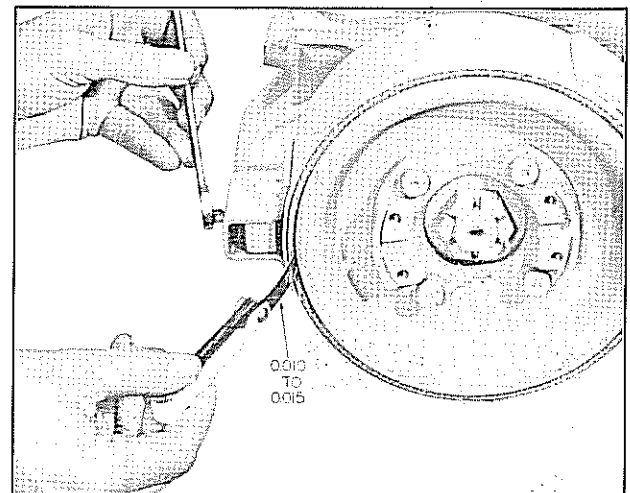

Plate 6291. Brake Band Centering Adjustment

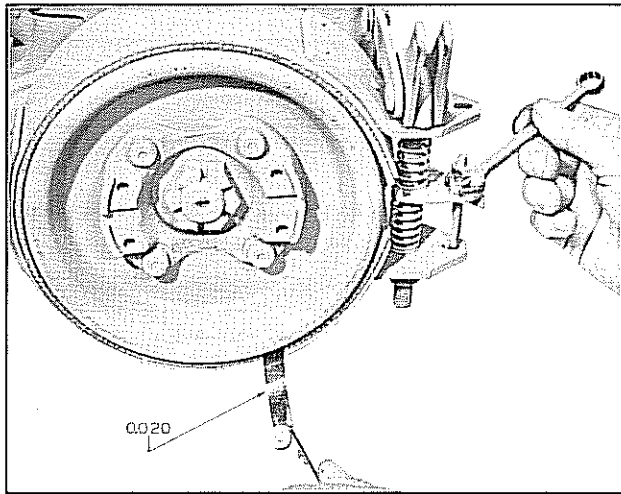

Plate 6290. Brake Band Lower Adjustment

d. Loosen lock nut from end of adjusting bolt and tighten adjusting bolt until feeler gauge placed between upper end of lining and brake drum indicates a 0.020 inch clearance. Tighten lock nut when this clearance is obtained. See Plate 6289.

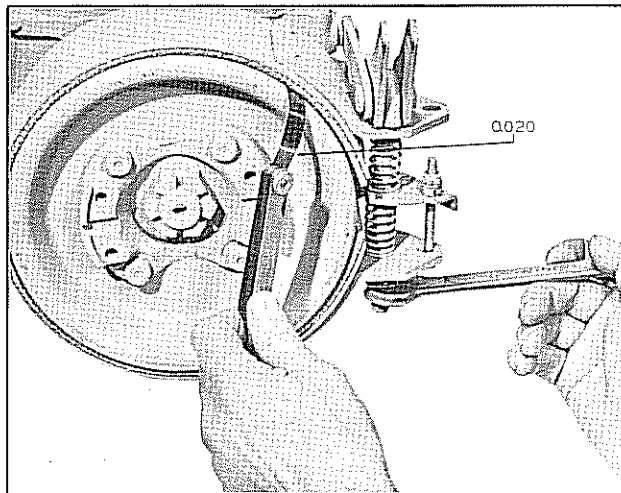

Plate 6289. Brake Band Upper Adjustment

e. Rotate adjusting knob, located at upper end of brake lever, clockwise until sufficient tension is obtained to properly apply parking brake when lever is actuated. See Plate 6505.

COOLING SYSTEM

Radiator Pressure Caps:

WARNING

USE EXTREME CARE IN REMOVING THE RADIATOR PRESSURE CAP. IN PRESSURE SYSTEMS, THE SUDDEN RELEASE OF PRESSURE CAN CAUSE A STEAM FLASH AND THE FLASH, OR THE LOOSENED CAP CAN CAUSE SERIOUS PERSONAL INJURY. LOOSEN CAP SLOWLY AND ALLOW STEAM TO ESCAPE.

1. Inspect pressure cap gasket and radiator filler neck to be sure they are providing a proper seal. If the rubber face of the valve is defective, a new cap should be installed.

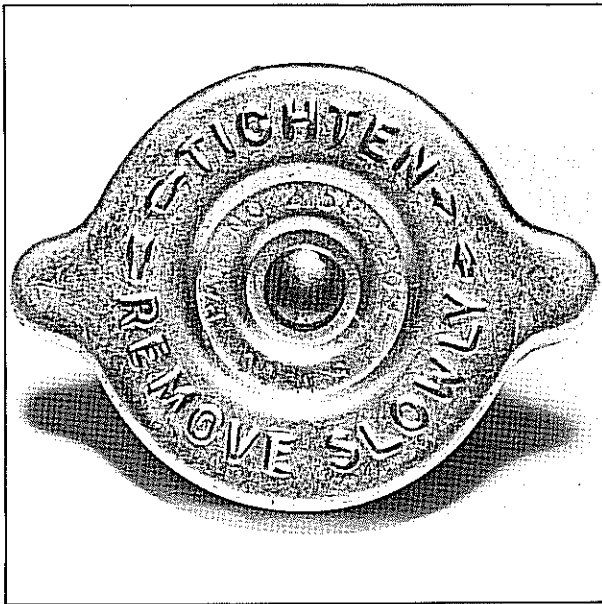

Plate 6458 Radiator Pressure Cap

2. Inspect pressure cap for freedom of operation.

Pressure caps employ a spring loaded, rubber-faced valve which presses against a seat in the radiator top tank. Pressure caps employ either a vacuum valve held against its seat under spring pressure, or a weighted vacuum valve which hangs open until forced closed by a surge of vapor or coolant. Check to be sure components are free to operate.

NOTE

IF A NEW CAP IS REQUIRED, ALWAYS INSTALL A CAP OF THE SAME TYPE AND PRESSURE RATING.

3. Inspect for dented or clogged overflow pipe. To remove clogged material, run a flexible wire through pipe until obstruction is removed.

When a pressure cap opens the sudden surge of vapor or liquid must pass thru the overflow pipe. If the pipe is dented or clogged, the pressure developed by the obstruction may cause damage to radiator or hoses.

Inspect and Clean Cooling System:

Check hose connections for coolant leaks as well as air leakage. Air leakage around hose connections allows oxygen into the system which is a major factor in corrosion.

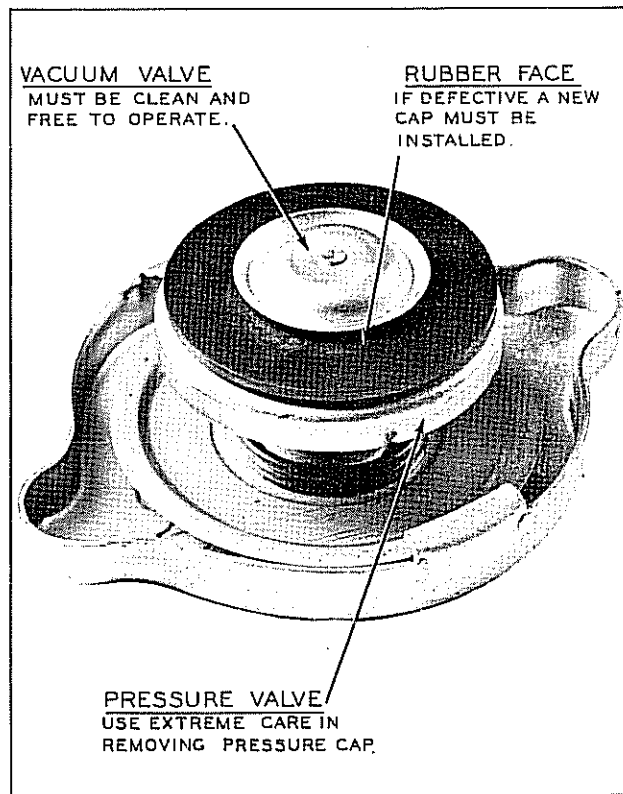

Plate 6459 Pressure Cap Gasket, Valve and Valve Gasket

NOTE

EXHAUST GAS LEAKAGE BETWEEN CYLINDER HEAD AND GASKET ALSO RESULTS IN CORROSION. IF EXHAUST GAS DISCHARGES INTO COOLANT, THE COOLANT AND THE GAS COMBINE TO FORM A VARIETY OF ACIDS. IT IS THEREFORE IMPORTANT THAT CYLINDER HEAD STUD NUTS BE DRAWN DOWN TO SPECIFICATIONS AS INSTRUCTED IN "ENGINE TUNE-UP".

LUBRICATION AND PREVENTIVE MAINTENANCE

Using a washing soda solution, flush cooling system in the following manner:

1. Drain system.
2. Replace half of volume with fresh water. Refer to Specifications for capacity.
3. Boil other half of volume and add washing soda until no more will dissolve.
4. Add hot soda solution to cooling system (fill up).
5. Operate engine normally for 24 hours.
6. Drain, flush, refill with clean water to which a soluble oil has been added in a proportion of 1 ounce per gallon of water.

Maintaining the cooling system efficiency is important, as engine temperatures must be brought up to and maintained within satisfactory range for efficient

operation; however, must be kept from overheating, in order to prevent damage to valves, pistons and bearings. Continued overheating may cause internal damage, while continuously low operating temperature wastes fuel, increases engine wear and causes oil sludge and corrosion of engine parts.

Overcooling may be caused by operating conditions such as excessive idling, low speeds and light loads during cold weather. Overheating may be caused by faulty thermostat, clogged radiator or an improperly adjusted fan belt.

CAUTION

NEVER POUR COLD WATER OR COLD ANTI-FREEZE INTO THE RADIATOR OF AN OVERHEATED ENGINE. ALLOW THE ENGINE TO COOL AND AVOID THE DANGER OF CRACKING THE CYLINDER HEAD OR BLOCK. KEEP ENGINE RUNNING WHILE ADDING WATER.

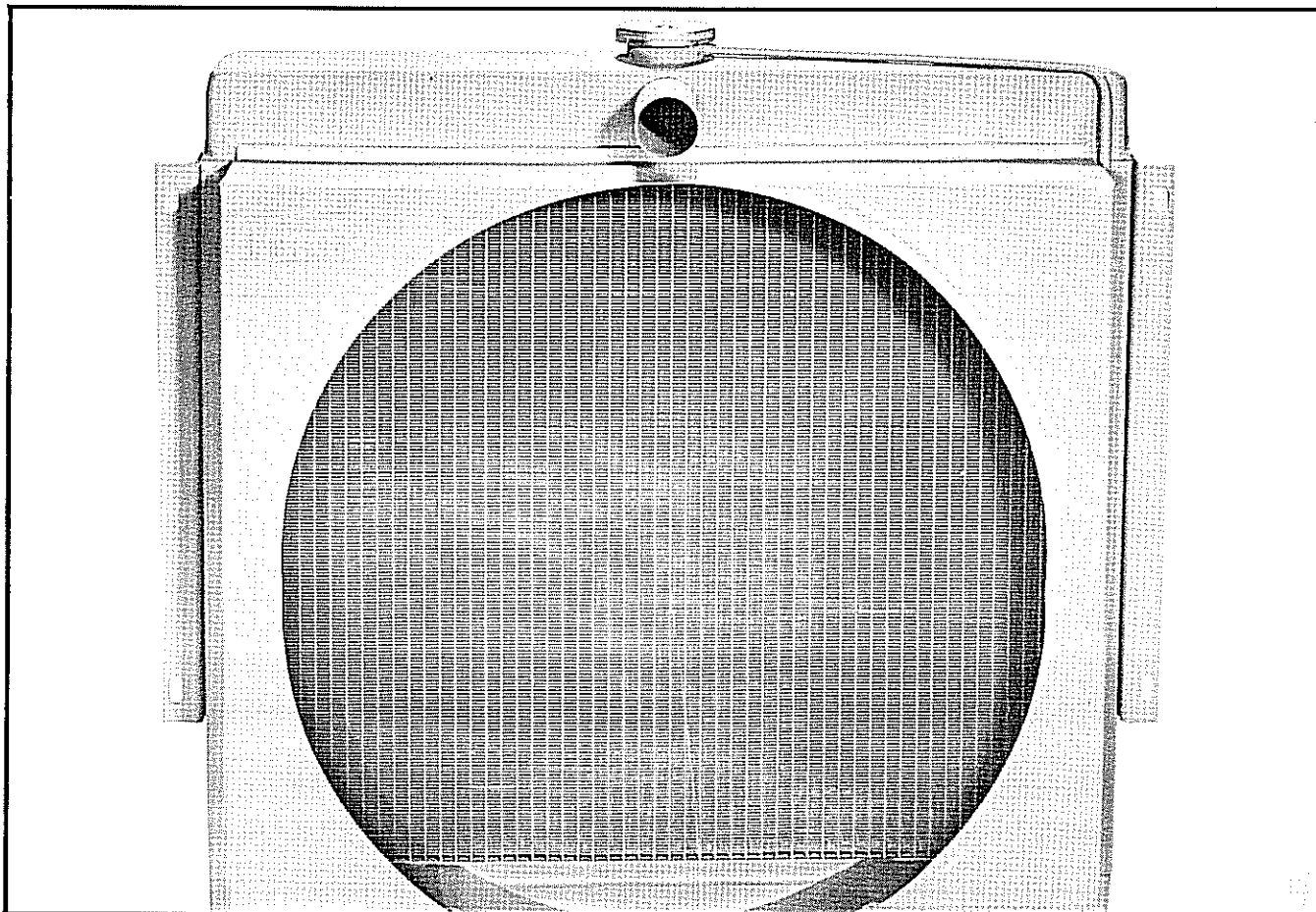

Plate 6461 Typical Radiator

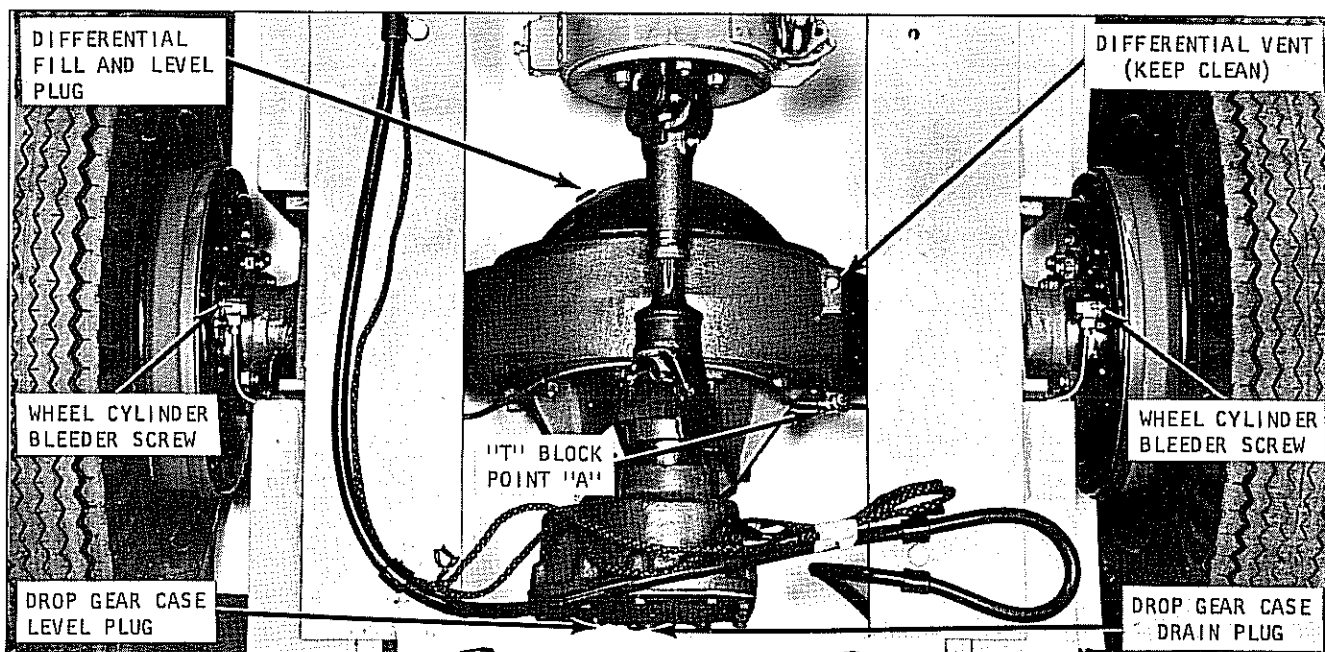

Plate 7435. Drop Gear Case and Differential - Drain and Refill

DIFFERENTIAL AND DROP GEAR CASE

1. Drain differential by removing the lower capscrew on the front cover of the differential bowl. Drain differential at operating temperatures. Removal of the filler/plug will allow full atmospheric pressure to enter the differential bowl and speed up the draining process.

NOTE

BEFORE REMOVING PLUGS FROM EITHER DIFFERENTIAL OR DROP GEAR CASE, CLEAN BOTH ASSEMBLIES SO THAT THE AREA AROUND THE DRAIN, FILL/LEVEL PLUGS IS ABSOLUTELY CLEAN.

2. Remove drain plug from the drop gear case and drain lubricant at operating temperature.

3. Replace drain plugs after both units are completely drained and tighten plugs securely.

4. Remove fill/level plug and fill differential with E.P.G.L. S.A.E. 90 Clark Specifications MSB. Do not fill above the level of the plug hole. Replace plug and securely tighten.

5. Remove fill/level plug of drop gear case and add one quart of E.P.G.L. S.A.E. 90. Then replace fill/level plug and securely tighten.

Refer to Specifications for combined capacity of differential and drop gear case.



INDUSTRIAL TRUCK DIVISION



LUBRICATION AND PREVENTIVE MAINTENANCE

NOTE

REFER TO ILLUSTRATION ON PAGE 1000H 1793.

VACUUM CONTROL (TRANSMISSION)

1. Check the operation of the vacuum control and solenoid unit, located to the left rear of the transmission. The distance between its front face and the transmission case should be 3/8-inch. If necessary, loosen the locknut, adjust the clearance to 3/8-inch; tighten the locknut.

2. Oil Pressure check for transmission operation. With a tachometer attached to the engine, remove the 1/8-inch pipe plug (9) and install a pressure gauge line in the pipe plug seat. Connect a 0-300 psi pressure gauge to the line. With the hand and service brakes applied, start the engine and allow the engine to reach normal temperature. Place the shift lever in the drive position. Accelerate the engine to 1000 rpm; the pressure gauge reading should be 80-100 psi.

CAUTION

DO NOT OPERATE THE ENGINE WITH THE TRANSMISSION IN DRIVE AND BRAKES APPLIED FOR MORE THAN 10 SECONDS AT ANY ONE INTERVAL.

3. If the correct pressure is not obtained in the above tests, remove the carburetor-to-vacuum control line at the vacuum control and install a vacuum gauge in the line. Repeat the check given in Step 2 above; the vacuum gauge should read 5.8 to 6.8 inches of mercury at 1000 rpm. If minor differences build up, refer to Step 4. A low vacuum reading would indicate a leak at the carburetor gasket, in the carburetor-to-vacuum control line, or in the vacuum control unit. Remove the line at the carburetor. Check to see if the trouble is in the line or the carburetor gasket by repeating the test with the vacuum gauge attached to the carburetor line fitting. A high reading indicates the line or carburetor adapter plate passages are plugged. If the trouble cannot be corrected, report it to the designated individual in authority.

4. To allow for a tolerance buildup of minor differences found in Step 2 above, the vacuum control can be repositioned slightly. To raise the control pressure slightly at the 1000 rpm check point, the vacuum control can be moved closer to the transmission case. To lower

the control pressure slightly, it can be moved away from the case. Before making any adjustments, check the position of the vacuum control front face in respect to the transmission case; there should be 3/8-inch clearance. The vacuum control must not be adjusted more than one-half turn of 1/32-inch from the 3/8-inch factory setting; any further adjustment would be ineffective and possibly cause the transmission to malfunction. After making the adjustment, make sure the locknut is tight. Remove the gauge from the pipe plug port and install the 1/8-inch pipe plug, tighten to a torque of 7 to 12 ft. lbs. If the adjustment of the control pressure cannot be made within the above limits, report the trouble to the designated individual in authority.

CONTROL PRESSURES. Control pressure varies with throttle opening and road speed. When the vehicle is held stationary with the brakes, control pressure varies with throttle opening only.

1. Remove the 1/8-inch pipe plug and install a pressure gauge line in the opening. Connect a 0-300 psi pressure gauge to the line. With the hand and service brakes applied, start the engine and allow engine to reach normal operating temperature.

CAUTION

DO NOT OPERATE THE ENGINE WITH THE TRANSMISSION IN ANY GEAR WHEN BRAKES ARE APPLIED FOR MORE THAN 10 SECONDS AT ANY ONE INTERVAL.

2. With the engine at idle and brakes applied move the shift lever to each position and observe the gauge readings. These pressure readings are called idle pressures; they should be between 50 and 70 psi.

3. With the accelerator pedal fully depressed and the brakes applied, move the shift lever into drive, and reverse positions; observe the gauge readings. Do not accelerate in neutral position. These pressure readings are called stall pressures; they should be between 130 and 160 psi.

4. If the idle pressures are found to be above those specified in 2 and 3, repeat the vacuum control check. If idle or stall pressures are below the limits



INDUSTRIAL TRUCK DIVISION



LUBRICATION AND PREVENTIVE MAINTENANCE

given in Step 2 and 3 above, report the trouble to the designated individual in authority. Remove the pressure gauge and line. Install the 1/8-inch pipe plug, tighten to a torque of 7 to 12 ft. lbs.

TORQUE CONVERTER

1. Install a tachometer on the engine. With the hand and service brakes applied, start the engine and allow it to reach normal operating temperature.

2. With the shift lever in drive range, depress the accelerator pedal fully and observe the tachometer reading. Normal converter stall speed is 1560 rpm. A stabilized tachometer reading, remaining steady for 5 to 10 seconds, at the normal converter stall speed, indicates the converter is operating normally. Any other tachometer reading should be reported to the designated individual in authority.

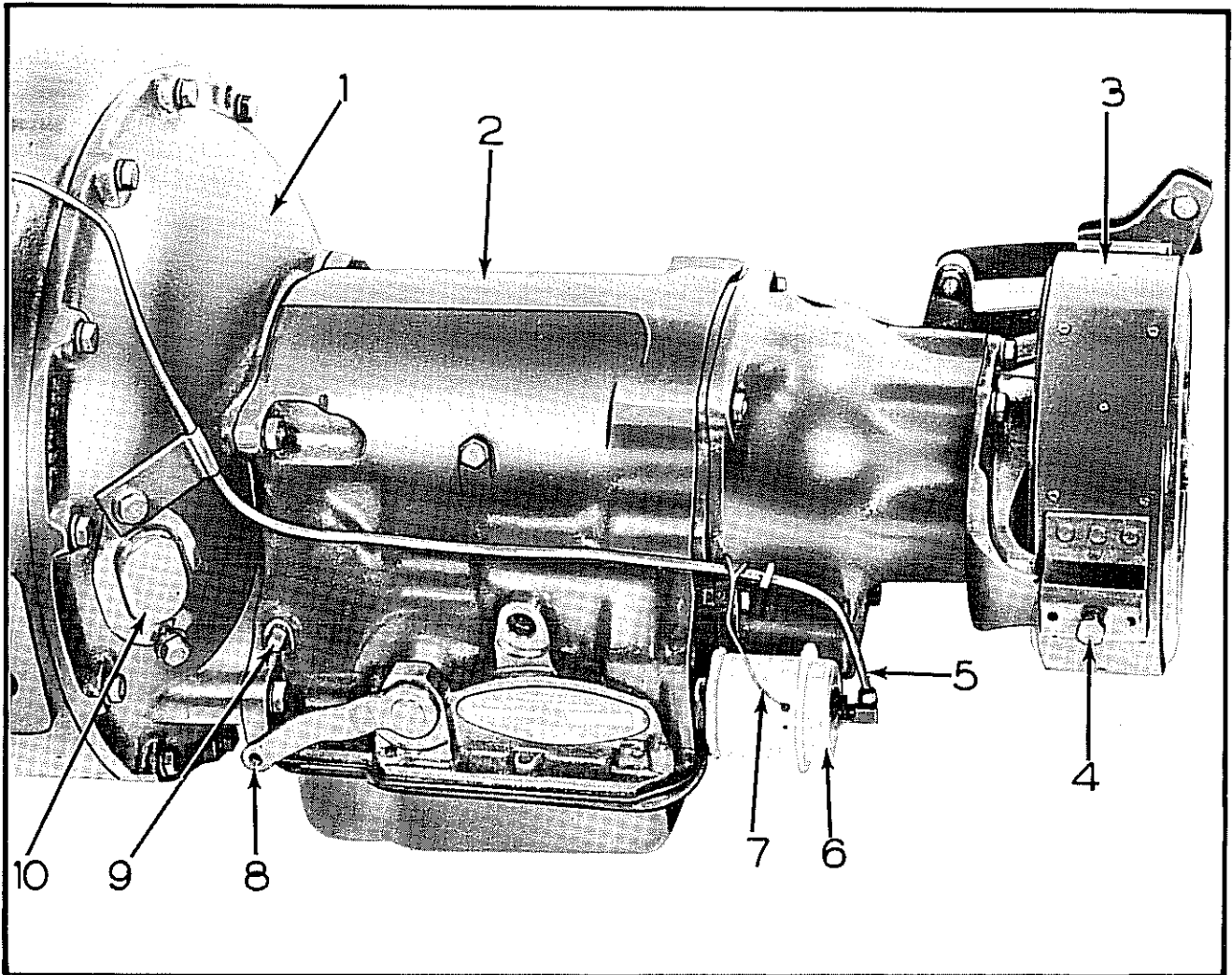

- | | |
|--------------------------------------|-------------------------------------|
| 1. Torque Converter Housing | 6. Vacuum Control and Solenoid Unit |
| 2. Transmission | 7. Not Used |
| 3. Parking Brake | 8. Manual shift lever |
| 4. Anchor Clip Screw | 9. Pressure gauge port pipe plug |
| 5. Carburetor-to-vacuum control line | 10. Converter housing cover plate |

Plate 5371. Transmission, Left Side

NEUTRAL STARTING SWITCH

1. Check the operation of the neutral starting switch by trying to start the engine with the shift lever in all positions. The engine should start only when the shift lever is in the N (neutral) position. **CAUTION: TEST WITH BRAKES APPLIED.**

2. Refer to the illustration on page 1000H 1794. With shift lever in neutral position, actuator pin (a) should contact and depress roller (b) of the neutral starting switch. If adjustment is necessary, loosen nuts (c & d) and move switch as required for correct adjustment. Tighten nuts (c & d).

LUBRICATION AND PREVENTIVE MAINTENANCE

ROAD TEST AND PERFORMANCE CHECK. A driving test should be made with the shift lever in D or drive range to check shift speeds.

1. Closed throttle downshift speed from third to second should be at 2 to 4 mph.

2. At 10 mph move the shift lever to L or low range. Closed throttle downshift from second to first should be at 5 to 7 mph.

3. If any of the shift speeds are not within the tolerances listed above, report the condition to the designated individual in authority.

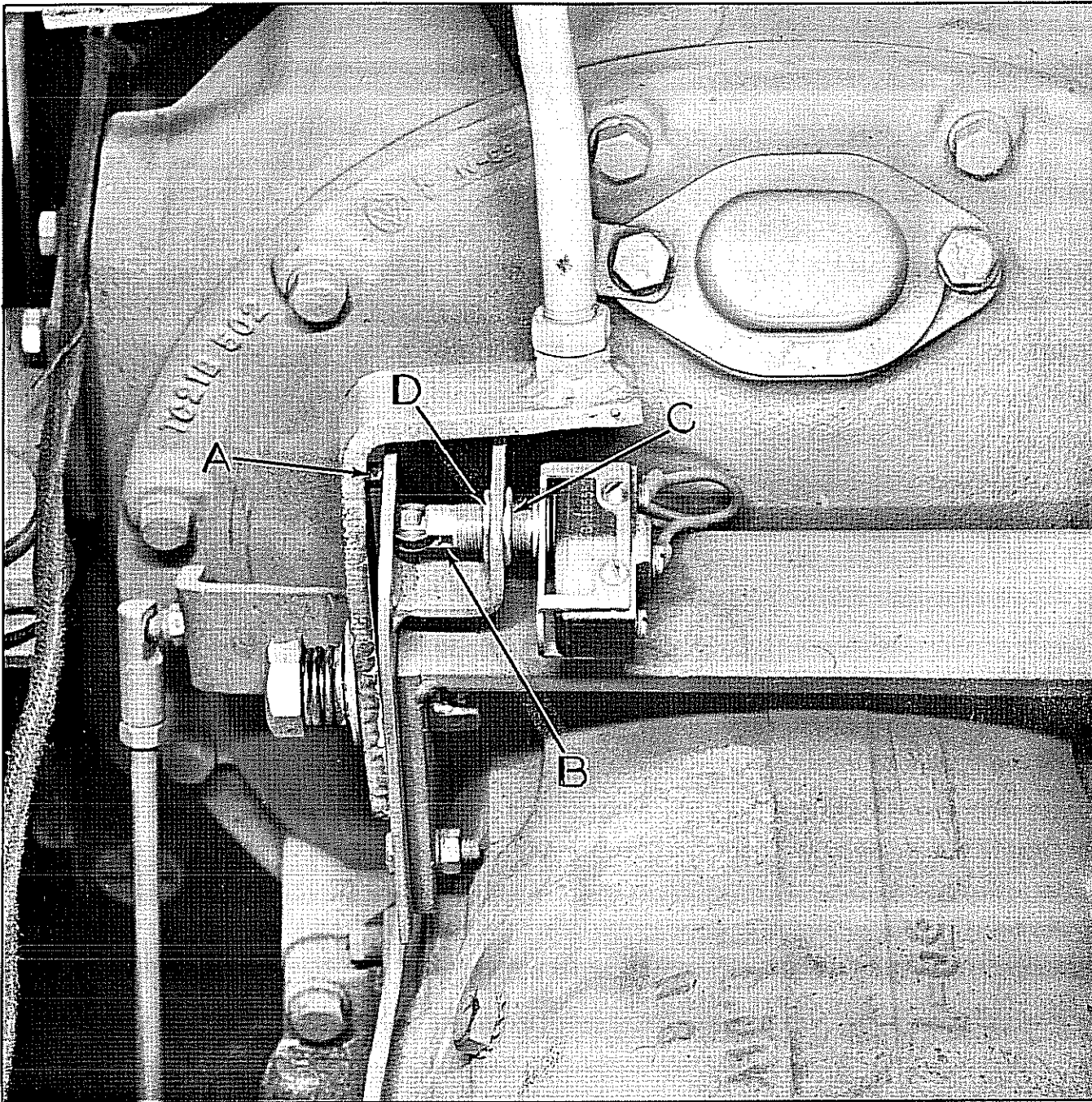

Plate 7721. Neutral Starting Switch Adjustment



INDUSTRIAL TRUCK DIVISION



TROUBLE SHOOTING GUIDE

ENGINE

TROUBLE	PROBABLE CAUSE	REMEDY
Starting motor will not crank engine.	<p>Battery discharged</p> <p>Battery cable terminals loose or corroded. Ignition Fuse blown.</p> <p>Starting motor drive gear jammed in flywheel teeth.</p> <p>Improper oil.</p> <p>Battery cable terminal broken.</p> <p>Poor starting switch contacts.</p> <p>Faulty Neutral Starting Switch.</p>	<p>Recharge or replace battery.</p> <p>Remove and clean, reinstall and tighten cables. Replace fuse.</p> <p>Loosen starting motor and free-up gear.</p> <p>Change oil to proper grade.</p> <p>Replace cable.</p> <p>Replace switch.</p> <p>Refer to Starting Motor.</p>
Starting motor operates, but fails to crank engine when switch is engaged.	<p>Starting motor gear does not engage flywheel.</p> <p>Starting motor or drive gear defective.</p>	<p>Remove starting motor, and clean drive mechanism.</p> <p>Replace starting motor.</p>
<u>Engine will not start.</u> No spark. Ammeter shows no discharge (Zero reading) with ignition switch "on".	<p>Ignition switch partly "on".</p> <p>Ignition switch defective.</p> <p>Ignition primary wires or starting motor cables broken or connections loose.</p> <p>Ignition coil primary winding open.</p> <p>Distributor points dirty.</p> <p>Distributor points not closing.</p> <p>Loose or corroded ground, or battery cable connections.</p>	<p>Turn switch "on" fully.</p> <p>Replace switch.</p> <p>Repair, or replace and tighten.</p> <p>Replace coil.</p> <p>Clean and adjust points.</p> <p>Adjust or replace points.</p> <p>Remove and clean, reinstall and tighten cables.</p>
<u>Engine will not start.</u> Ammeter showing abnormal discharge with ignition switch "on".	<p>Defective condenser.</p> <p>Short-circuited or burned distributor cap or rotor.</p> <p>Short-circuited wire between ammeter and ignition switch.</p> <p>Short-circuited primary winding in ignition coil.</p> <p>Distributor points not opening.</p>	<p>Replace condenser.</p> <p>Replace parts.</p> <p>Repair or replace wire.</p> <p>Replace coil.</p> <p>Clean or replace, and adjust points.</p>
Weak spark.	<p>Distributor points pitted or burned.</p> <p>Distributor condenser weak.</p> <p>Ignition coil weak.</p>	<p>Clean or replace, and adjust points.</p> <p>Replace condenser.</p> <p>Replace coil.</p>



INDUSTRIAL TRUCK DIVISION



TROUBLE SHOOTING GUIDE

ENGINE (Continued)

TROUBLE	PROBABLE CAUSE	REMEDY
<p><u>Engine will not start.</u> Weak spark (continued)</p>	<p>Primary wire connections loose.</p> <p>High-tension, spark plug wires, or distributor cap wet.</p> <p>High-tension, spark plug wires, or distributor cap damaged.</p> <p>Distributor cap or rotor burned or broken.</p> <p>Spark plug gap incorrect.</p> <p>Short-circuited secondary circuit in coil.</p>	<p>Tighten.</p> <p>Dry thoroughly.</p> <p>Replace defective parts.</p> <p>Replace defective parts.</p> <p>Reset gaps.</p> <p>Replace coil.</p>
<p>Good spark.</p>	<p>Fuel tank empty.</p> <p>Dirt or water in carburetor, or float stuck.</p> <p>Carburetor and engine flooded by excessive use of choke.</p> <p>Fuel does not reach carburetor.</p> <p>Dirt in fuel lines or tank.</p> <p>Fuel line pinched.</p> <p>Ignition wires incorrectly installed in distributor cap.</p> <p>Ignition timing incorrect.</p> <p>Fuel Strainer Clogged.</p> <p>Fuel pump does not pump.</p> <p>Lack of engine compression.</p>	<p>Refill tank.</p> <p>Drain and clean carburetor.</p> <p>Depress accelerator pedal fully, crank engine with starting motor, when engine starts, reset throttle and leave choke control "in".</p> <p>Inspect for damaged or leaky lines or air leak into line between tank and fuel pump.</p> <p>Disconnect lines, drain tank, and blow out lines.</p> <p>Repair or replace line.</p> <p>Install wires correctly.</p> <p>Reset timing.</p> <p>Remove and clean strainer.</p> <p>Clean screen, replace pump if defective.</p> <p>Report to designated individual in authority.</p>
<p>Backfiring.</p>	<p>Ignition out of time.</p> <p>Spark plug wires incorrectly installed distributor cap or at spark plugs.</p> <p>Distributor cap cracked or shorted.</p> <p>Valve holding open.</p>	<p>Reset timing.</p> <p>Install wires correctly.</p> <p>Replace cap.</p> <p>Report to designated individual in authority.</p>

TROUBLE SHOOTING GUIDE

ENGINE (Continued)

TROUBLE	PROBABLE CAUSE	REMEDY
Engine operates, but backfires and spits.	Improper ignition timing.	Reset timing.
	Spark plug wires incorrectly installed in distributor cap.	Install wires correctly.
	Dirt or water in carburetor.	Drain and clean carburetor.
	Carburetor improperly adjusted.	Clean and adjust carburetor.
	Carburetor float level low.	Report to designated individual in authority.
	Valve sticking or not seating properly, burned or pitted.	Report to designated individual in authority.
	Excessive carbon in cylinders.	Remove carbon from cylinders.
	Valve springs weak.	Report to designated individual in authority.
	Heat control valve not operating.	Free-up, and adjust valve.
	Fuel pump pressure low.	Clean screen; replace pump, if defective.
	Fuel strainer clogged.	Remove and clean strainer.
	Partly clogged or pinched fuel lines.	Clean and repair lines.
Intake manifold leak.	Inspect gaskets and tighten manifold stud nuts.	
Distributor cap cracked or shorted.	Replace cap.	
Engine stalls on idle.	Carburetor throttle valve closes too far, or idle mixture incorrect.	Adjust carburetor.
	Carburetor choke valve remains closed.	Free-up and lubricate valve.
	Dirt or water in idler passages of Carburetor.	Clean or replace carburetor.
	Air leak at intake manifold.	Inspect gaskets and tighten manifold stud nuts.
	Heat control valve defective.	Free-up and adjust valve.
	Spark plugs defective, gaps incorrect.	Clean or replace spark plugs, set gap clearance.
	Ignition timing early.	Reset timing.
	Low compression.	Report to designated individual in authority.
	Water leak in cylinder head or head gaskets.	Replace gasket; report cylinder head leak to designated individual in authority.



INDUSTRIAL TRUCK DIVISION



TROUBLE SHOOTING GUIDE

ENGINE (Continued)

TROUBLE	PROBABLE CAUSE	REMEDY
Engine misfires on one or more cylinders.	<p>Dirty spark plugs.</p> <p>Spark plug gap incorrect.</p> <p>Cracked spark plug porcelain.</p> <p>Spark plug wires grounded.</p> <p>Spark plug wires incorrectly installed in cap or at spark plugs.</p> <p>Distributor cap or rotor burned or broken.</p> <p>Valve tappet holding valve open.</p> <p>Low engine compression.</p> <p>Leaky cylinder head gasket.</p> <p>Cracked cylinder block, broken valve tappet or tappet screw.</p>	<p>Clean, adjust, or replace plugs.</p> <p>Reset gap.</p> <p>Replace spark plug.</p> <p>Replace wires.</p> <p>Install wires correctly.</p> <p>Replace defective parts.</p> <p>Report to designated individual in authority.</p> <p>Report to designated individual in authority.</p> <p>Replace gasket.</p> <p>Report to designated individual in authority.</p>
Engine does not idle properly.	<p>Ignition timing.</p> <p>Dirty spark plugs, or gaps too close.</p>	<p>Reset timing.</p> <p>Clean and adjust spark plugs.</p>
Engine misses at high speeds.	<p>Ignition coil or condenser weak.</p> <p>Distributor points sticking, dirty or improperly adjusted.</p> <p>Distributor rotor or cap cracked or burned.</p> <p>Leaky cylinder head gaskets.</p> <p>Uneven cylinder compression.</p> <p>High-tension or spark plug wires leaky, cracked insulation.</p> <p>Carburetor choke not adjusted.</p> <p>Carburetor accelerating pump system defective, dirt in metering jets or float level incorrect.</p> <p>Fuel pump defective, causing lack of fuel.</p> <p>Air cleaner dirty.</p> <p>Heat control valve defective.</p>	<p>Replace defective parts.</p> <p>Clean, adjust, or replace points.</p> <p>Replace defective parts.</p> <p>Replace gaskets.</p> <p>Report to designated individual in authority.</p> <p>Replace defective parts.</p> <p>Adjust choke.</p> <p>Report to designated individual in authority.</p> <p>Clean screen, replace defective pump.</p> <p>Clean complete air cleaner and refill oil cup.</p> <p>Free-up and adjust</p>

TROUBLE SHOOTING GUIDE

ENGINE (Continued)

TROUBLE	PROBABLE CAUSE	REMEDY
Engine misses at high speeds. (continued)	<p>Valves sticking, weak or broken valve springs.</p> <p>Fuel strainer clogged.</p> <p>Weak distributor bracket arm spring</p> <p>Excessive play in distributor shaft bearing.</p> <p>Spark plugs defective, dirty or gap incorrectly set.</p>	<p>Report to designated individual in authority.</p> <p>Remove and clean strainer.</p> <p>Replace point set.</p> <p>Replace distributor.</p> <p>Clean, adjust or replace spark plugs.</p>
Engine pings (Spark Knock).	<p>Ignition timing early.</p> <p>Distributor automatic spark advance stuck in advance position, or spring broken.</p> <p>Excessive carbon deposit in cylinders.</p> <p>Incorrect fuel.</p>	<p>Reset timing.</p> <p>Replace distributor.</p> <p>Remove cylinder head and clean.</p> <p>Drain, use correct fuel.</p>
Engine lacks power.	<p>Ignition timing late.</p> <p>Incorrect fuel.</p> <p>Leaky cylinder head gasket.</p> <p>Excessive carbon formation.</p> <p>Engine runs cold.</p> <p>Insufficient oil, or improper grade oil.</p> <p>Oil system failure.</p> <p>Air Cleaner dirty.</p> <p>Spark plug gaps too wide.</p> <p>Choke valve partially closed, or throttle does not open fully.</p> <p>Manifold heat control inoperative.</p> <p>Exhaust pipe, muffler or tail pipe obstructed.</p> <p>Low compression, broken valve springs, sticking valves.</p>	<p>Reset timing.</p> <p>Use correct fuel.</p> <p>Replace gasket.</p> <p>Remove cylinder head, and clean cylinder head, piston heads, cylinder block, and valves.</p> <p>Test thermostat; in cold weather, cover radiator.</p> <p>Lubricate in accordance with lubrication section.</p> <p>Report to designated individual in authority.</p> <p>Clean complete air cleaner, change oil in cup.</p> <p>Reset gaps.</p> <p>Adjust valve or throttle.</p> <p>Free-up and adjust control.</p> <p>Service or replace obstructed parts.</p> <p>Report to designated individual in authority.</p>



INDUSTRIAL TRUCK DIVISION



TROUBLE SHOOTING GUIDE

ENGINE (Continued)

TROUBLE	PROBABLE CAUSE	REMEDY
Engine lacks power. (Continued)	Improper tappet adjustment. Lack of fuel.	Adjust tappets. Clean filter, inspect fuel pump, inspect carburetor for water or dirt and clean if necessary.
Engine overheats.	Cooling system deficient. Water low, air flow through radiator core restricted. Clogged radiator core (Clogged internally). Cylinder head gasket leaking. Radiator or water pump leaking. Damaged or deteriorated hose or fan belt. Loose fan belt. Cylinder block or head leaking. Ignition timing incorrect. Damaged muffler, bent or clogged exhaust pipe. Excessive carbon in cylinders. Insufficient oil, or improper grade. Air Cleaner restricted. Inoperative thermostat. Water pump impeller broken. Poor compression. Valve timing incorrect.	Clean radiator core from engine side with compressed air or water, or fill radiator to proper level. Clean by flushing radiator. Tighten cylinder head stud nuts and/or replace gasket. Repair or replace defective parts. Replace defective parts. Adjust fan belt tension. Report to designated individual in authority. Reset timing. Service or replace defective parts. Remove cylinder head, and clean cylinder head, piston heads cylinder block, and valves. Refer to Lubrication Instructions. Clean complete change oil in cup. Replace thermostat and gasket. Replace pump. Report to designated individual in authority. Reset timing.
High fuel consumption.	High engine speeds (Excessive driving in lower gear range). Air cleaner clogged. Carburetor float level too high, accelerating pump not properly adjusted. Fuel line leaks.	Correct driving practice. Clean complete air cleaner and change oil in cup. Report to designated individual in authority. Correct leaks, replace lines.



INDUSTRIAL TRUCK DIVISION



TROUBLE SHOOTING GUIDE

ENGINE (Continued)

TROUBLE	PROBABLE CAUSE	REMEDY
High fuel consumption. (Continued)	<p>Overheated engine.</p> <p>Carburetor parts worn or broken.</p> <p>Fuel pump pressure too high, or leaky diaphragm.</p> <p>Engine running cold.</p> <p>Ignition incorrectly timed.</p> <p>Spark advance stuck.</p> <p>Leaking fuel pump bowl gasket.</p> <p>Low compression.</p> <p>Carburetor controls sticking.</p> <p>Engine idles too fast.</p> <p>Spark plugs dirty.</p> <p>Weak coil or condenser</p> <p>Clogged muffler, or bent exhaust pipe.</p> <p>Loose engine mounts, permitting engine to shake and raise fuel level in carburetor.</p>	<p>See "Engine overheats".</p> <p>Replace fuel carburetor.</p> <p>Replace fuel pump.</p> <p>Inspect thermostat, cover radiator in winter.</p> <p>Reset timing.</p> <p>Replace distributor.</p> <p>Replace gasket.</p> <p>Report to designated individual in authority.</p> <p>Free-up and lubricate controls.</p> <p>Adjust carburetor throttle stop screw.</p> <p>Clean or replace spark plugs.</p> <p>Replace coil or condenser.</p> <p>Service or replace defective parts.</p> <p>Tighten; if damaged, replace defective mounts.</p>
High oil consumption.	<p>High engine speeds, or excessive driving in low gear range.</p> <p>Oil leaks.</p> <p>Improper grade oil, or diluted oil.</p> <p>Overheating of engine causing thinning of oil.</p> <p>Oil filter clogged.</p> <p>Defective piston or rings, excessive side clearance of intake valves in guides, cylinder bores worn (scored, out-of-round, tapered); excessive bearing clearance, misaligned connecting rods.</p>	<p>Correct driving practice.</p> <p>Replace leaking gaskets.</p> <p>Use new oil of proper grade.</p> <p>See "Engine overheats".</p> <p>Clean filter case thoroughly and replace element.</p> <p>Report to designated individual in authority.</p>



INDUSTRIAL TRUCK DIVISION



TROUBLE SHOOTING GUIDE

ENGINE (Continued)

TROUBLE	PROBABLE CAUSE	REMEDY
Low oil pressure.	<p>Insufficient oil supply.</p> <p>Improper grade of oil, or diluted oil foaming at high speeds.</p> <p>Oil too heavy (funneling in cold weather).</p> <p>Oil pump screen clogged.</p> <p>Oil leaks.</p> <p>Faulty oil pump, pressure regulator valve stuck or improperly adjusted, or spring broken.</p>	<p>Fill crankcase to prescribed level.</p> <p>Change oil, inspect crankcase ventilator, inspect for water in oil.</p> <p>Change to proper grade oil. (Refer to Lubrication Instructions.)</p> <p>Remove oil pan and clean pump screen.</p> <p>Report to designated individual in authority.</p> <p>Report to designated individual in authority.</p>
Defective valves.	<p>Incorrect tappet adjustment.</p> <p>Other valve troubles.</p>	<p>Adjust tappets.</p> <p>Report to designated individual in authority.</p>
Abnormal engine noises.	<p>Loose fan, fan pulley or belt, heat control valve.</p> <p>Leaking intake or exhaust manifold or gaskets, cylinder head gasket, or spark plugs.</p> <p>Overheated engine, clogged exhaust system.</p> <p>Other abnormal engine noises.</p>	<p>Tighten or correct conditions as required.</p> <p>Tighten loose components or replace defective gaskets.</p> <p>Remove obstruction from exhaust system. Inspect for further serviceability.</p> <p>Report to designated individual in authority.</p>
Poor compression.	<p>Incorrect tappet adjustment.</p> <p>Leaking, sticking, or burned valves; sticking tappets; valve spring weak or broken; valve stems and guides worn; piston ring grooves worn or rings worn, broken, or stuck; cylinder bores scored or worn.</p>	<p>Adjust tappets.</p> <p>Report to designated individual in authority.</p>



INDUSTRIAL TRUCK DIVISION



TROUBLE SHOOTING GUIDE

FUEL SYSTEM

TROUBLE	PROBABLE CAUSE	REMEDY
Fuel does not reach carburetor.	No fuel in fuel tank. Fuel pump inoperative. Fuel line air leak between tank and fuel pump. Fuel line clogged. Fuel tank cap vent clogged.	Fill fuel tank. Replace pump. Repair or replace line. Disconnect and blow out lines. Clean vent.
Fuel reaches carburetor, but does not reach cylinders.	Choke does not close. Fuel passage in carburetor clogged. Carburetor float valve stuck closed.	Free-up and lubricate, inspect for proper operation. Clean or replace carburetor. Report to designated individual in authority.
High fuel consumption.	Lubricant in power train too heavy. Incorrect adjustment of carburetor. Vehicle overloaded. Tires improperly inflated. Tight brakes.	Use correct lubricant. Adjust carburetor. Reduce loads to specified maximum capacity. Inflate tires properly. Adjust brakes.
Low fuel pressure.	Air leak in fuel lines. Fuel pump defective, diaphragm broken; valves leaking, linkage worn. Fuel lines clogged.	Tighten connections, repair lines if damaged. Replace fuel pump. Clean or replace lines.
Engine idles too fast.	Improper carburetor throttle stop adjustment. Carburetor control sticking. Control return spring weak.	Adjust throttle stop screw. Free-up and lubricate control. Replace spring.
Fuel gauge does not register.	Loose wire connection at instrument panel or tank unit. Instrument panel unit or tank unit inoperative.	Tighten connections. Replace unit.



INDUSTRIAL TRUCK DIVISION



TROUBLE SHOOTING GUIDE

COOLING SYSTEM

TROUBLE	PROBABLE CAUSE	REMEDY
Overheating.	Unusual operating conditions of high temperature.	Inspect. (Refer to "Engine overheats".)
Loss of cooling solution.	Loose hose connections. Damaged or deteriorated hose. Leaking radiator.	Tighten hose connections. Replace hoses. Repair or replace radiator.
Engine operates too cool.	Thermostat sticking. Low air temperature.	Replace thermostat and gasket. Cover radiator.
Noises.	Frayed or loose fan belt. Water pump defective.	Replace or adjust belt. Replace pump.

THE ENGINE COOLING SYSTEM

Trouble spots resulting from service neglect

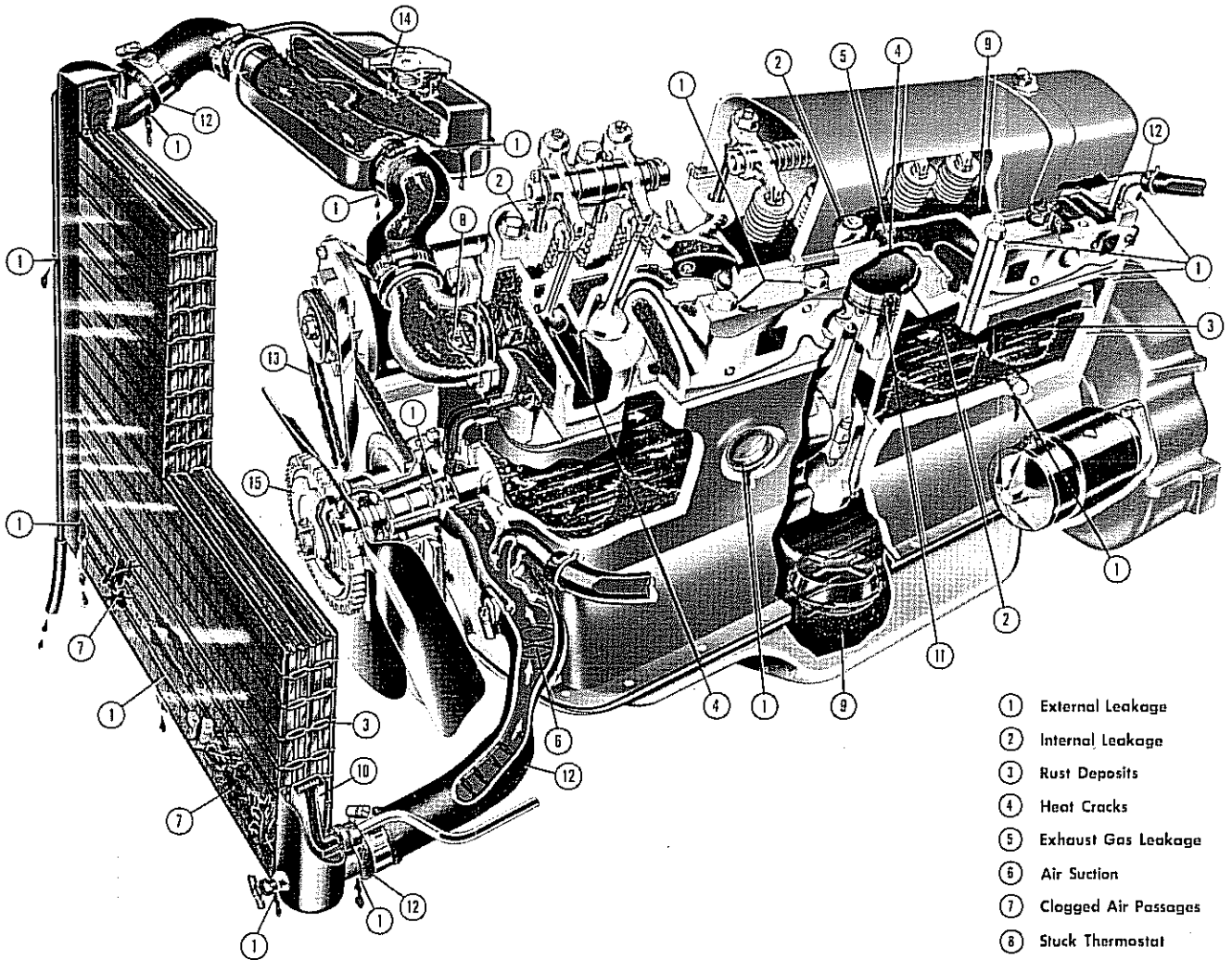

- ① External Leakage
- ② Internal Leakage
- ③ Rust Deposits
- ④ Heat Cracks
- ⑤ Exhaust Gas Leakage
- ⑥ Air Suction
- ⑦ Clogged Air Passages
- ⑧ Stuck Thermostat
- ⑨ Sludge Formation in Oil
- ⑩ Transmission Oil Cooler
- ⑪ Heat Damage
- ⑫ Hose Failure
- ⑬ Worn Fan Belt
- ⑭ Pressure Cap Leakage
- ⑮ Temperature Control Fan Drive

The cooling system depicted here does not represent that of any particular make of car, it incorporates features used by many different manufacturers.

All Rights Reserved.
No Part of This Chart May Be Reproduced Without Permission From Union Carbide Corporation.

Cooling System Care Pays!

This chart is distributed as a public service by
UNION CARBIDE CONSUMER PRODUCTS COMPANY

 Division of Union Carbide Corporation



INDUSTRIAL TRUCK DIVISION



TROUBLE SHOOTING GUIDE

IGNITION SYSTEM

TROUBLE	PROBABLE CAUSE	REMEDY
Ignition system troubles.	<p>Weak spark.</p> <p>Timing incorrect.</p> <p>Moisture on distributor wires, coil, or spark plugs.</p> <p>Ignition switch inoperative.</p> <p>Primary or secondary wiring loose, broken, or grounded.</p> <p>Coil defective.</p> <p>Distributor defective.</p> <p>Spark plug defective.</p>	<p>Refer to "Engine will not start".</p> <p>Retime ignition.</p> <p>Clean and dry thoroughly.</p> <p>Replace switch.</p> <p>Service.</p> <p>Refer to "Ignition coil troubles", below.</p> <p>Refer to "Distributor troubles", below.</p> <p>Refer to spark plug troubles below.</p>
Ignition coil.	<p>Connections loose; dirty or broken external wire, wet.</p> <p>Coil defective.</p>	<p>Clean and tighten, or repair, dry thoroughly.</p> <p>Replace coil.</p>
Distributor troubles.	<p>Distributor breaker points dirty or pitted, point gaps incorrect.</p> <p>Distributor breaker point arm spring weak.</p> <p>Distributor breaker points sticking.</p> <p>Distributor automatic advance defective.</p> <p>Distributor cap or rotor shorted, cracked or broken.</p> <p>Distributor rotor does not turn.</p> <p>Condenser defective.</p>	<p>Clean, adjust or replace breaker points.</p> <p>Replace breaker point arm.</p> <p>Free-up breaker points.</p> <p>Lubricate and free-up. If seized, replace distributor.</p> <p>Replace defective parts.</p> <p>Report to designated individual in authority.</p> <p>Replace condenser.</p>
Spark plug troubles.	<p>Cracked, broken, leaking, or improper type.</p> <p>Spark plug wires incorrectly installed on plugs or in distributor cap.</p> <p>Spark plugs dirty; gap incorrect.</p> <p>Spark plug porcelain cracked or broken.</p>	<p>Replace spark plug.</p> <p>Install wires correctly.</p> <p>Clean, set gaps, or replace plugs.</p> <p>Replace plug.</p>



INDUSTRIAL TRUCK DIVISION



TROUBLE SHOOTING GUIDE

STARTING MOTOR

TROUBLE	PROBABLE CAUSE	REMEDY
Starting motor cranks engine slowly.	<p>Engine oil too heavy.</p> <p>Battery charge low.</p> <p>Battery cell shorted.</p> <p>Battery connections corroded, broken, or loose.</p> <p>Dirty commutator.</p> <p>Insufficient brush surface contact.</p> <p>Defective starting motor.</p> <p>Starting switch defective.</p>	<p>Change to proper grade oil.</p> <p>Recharge or replace battery.</p> <p>Replace battery.</p> <p>Clean and tighten, or replace cables.</p> <p>Clean commutator.</p> <p>Free-up or replace brush.</p> <p>Replace starting motor.</p> <p>Replace switch.</p>
Starting motor does not crank engine.	<p>Engine oil too heavy.</p> <p>Starting motor, Solenoid, or cables defective; loose connections.</p> <p>Starting motor pinion gear jammed in flywheel drive gear.</p> <p>Dirty drive mechanism.</p> <p>Faulty Relay Switch.</p> <p>Ignition Fuse Blown.</p> <p>Faulty Ignition Switch.</p> <p>Faulty Neutral Starting Switch.</p>	<p>Change to proper grade oil.</p> <p>Replace or tighten loose connections.</p> <p>Remove starting motor and reinstall. Replace defective driving gear.</p> <p>Clean and lubricate drive mechanism.</p> <p>Replace Relay Switch.</p> <p>Replace Fuse.</p> <p>Replace Switch.</p> <p>Replace Switch.</p> <p>NOTE: The INDEX of this manual will list an ADJUSTABLE Neutral Starting Switch if your machine is so equipped.</p>



INDUSTRIAL TRUCK DIVISION



TROUBLE SHOOTING GUIDE

ALTERNATOR TROUBLES

TROUBLE	PROBABLE CAUSE	REMEDY
Noisy alternator.	Worn or dirty bearings Loose mounting bolts. Loose drive pulley. Defective diode. Defective stator.	Report to designated person in authority. Tighten as required. Tighten shaft nut. Report to designated person in authority. Report to designated person in authority.

C

C

C



INDUSTRIAL TRUCK DIVISION



TROUBLE SHOOTING GUIDE

BATTERY, LIGHTS AND HORN

TROUBLE	PROBABLE CAUSE	REMEDY
Battery discharged.	<p>Battery solution level low.</p> <p>Short in battery cell.</p> <p>Generator not charging.</p> <p>Loose or dirty connections; broken cables.</p> <p>Excessive use of starting motor.</p> <p>Idle battery, or excessive use of lights with engine at idle.</p> <p>Short circuits.</p>	<p>Add distilled water to bring level above plates; inspect for cracked case.</p> <p>Replace battery.</p> <p>Inspect generator, fan belt, and regulator.</p> <p>Clean and tighten connections; replace cables.</p> <p>Tune up engine; charge battery.</p> <p>Recharge or replace battery. Use lights sparingly.</p> <p>Replace defective wiring.</p>
Battery (other troubles)	<p>Overheated battery.</p> <p>Case bulged (or out of shape).</p>	<p>Inspect for short circuit or excessive generator charge.</p> <p>Inspect for overcharging and over-tightening of hold-down screws.</p>
Light switch.	<p>Loose or dirty connections; broken wire.</p> <p>Defective switch.</p>	<p>Clean and tighten; replace broken wire.</p> <p>Replace switch.</p>
Wiring.	<p>Loose or dirty connections; broken wire or terminal.</p>	<p>Clean, tighten, repair or replace. Wire or terminal.</p>
Lights do not light.	<p>Switch not fully "on".</p> <p>Loose or dirty connections; broken wire.</p> <p>Wiring circuit short-circuited, or open.</p> <p>Light burned out.</p>	<p>Turn switch "on" fully.</p> <p>Clean and tighten; replace or repair wire or terminal.</p> <p>Correct short circuit or replace defective parts.</p> <p>Replace light.</p>
Lights dim.	<p>Loose or dirty connection.</p> <p>Wiring short-circuited.</p> <p>Defective switch.</p>	<p>Clean and tighten connections.</p> <p>Correct short circuit or replace defective parts.</p> <p>Replace switch.</p>



INDUSTRIAL TRUCK DIVISION



TROUBLE SHOOTING GUIDE

BATTERY, LIGHTS AND HORN (Continued)

TROUBLE	PROBABLE CAUSE	REMEDY
Horn troubles.	Loose or dirty wiring connections.	Clean and tighten connections.
Horn sounds continuously.	Short-circuit in wiring between horn and horn button.	Replace wire.
Improper tone.	Loose or dirty wiring connections.	Clean and tighten connections.
	Cover or bracket screws loose.	Tighten.
	Points adjusted improperly.	Adjust points.
Horn will not operate.	Horn Fuse Blown.	Replace Fuse.
	Open Circuit.	Trace, repair or replace as required.
	Faulty Horn Relay.	Replace relay.



INDUSTRIAL TRUCK DIVISION



TROUBLE SHOOTING GUIDE

TRANSMISSION

TROUBLE	PROBABLE CAUSE	REMEDY
Excessive noise.	Incorrect driving practice. Insufficient lubricant. Gears or bearings broken or worn; gears worn on splines. Overheated transmission.	Correct practice. Add lubricant. Replace transmission Inspect lubricant grade and supply.
Inoperative in all ranges.	Shift lever linkage slipping or broken. Inoperative vacuum control. Internal trouble.	Check linkage and repair. Check operation of vacuum control and solenoid unit. Report to designated individual in authority.
Engine starts in ranges other than neutral.	Neutral starting switch out of position.	Reposition switch.
Shifting delayed or soft.	Low vacuum to vacuum control.	Check vacuum from carburetor.
Loss of lubricant.	Worn or damaged seals or gaskets.	Report to designated individual in authority.
Downshift rough with closed throttle.	Vacuum control not positioned correctly. Internal trouble.	Reposition as directed. Report to designated individual in authority.
High torque converter oil temperatures.	Improper driving practices. Low transmission fluid level. Internal trouble.	Correct driving practice. Check and fill. Report to designated individual in authority.



INDUSTRIAL TRUCK DIVISION



TROUBLE SHOOTING GUIDE

DRIVE AXLE

TROUBLE	PROBABLE CAUSE	REMEDY
Trouble.	Naisy gears or backlash. Damaged axle. Abnormal tire wear. Lubrication leaks.	Report to designated individual in authority. Replace axle. Inflate tires properly. Drain excessive lubricant; clean housing vent; remove excessive grease in wheel hubs; replace leaking defective gaskets.



INDUSTRIAL TRUCK DIVISION



TROUBLE SHOOTING GUIDE

STEERING AXLE

TROUBLE	PROBABLE CAUSE	REMEDY
Trouble.	Damaged axle. Lubrication leaks. Incorrect caster or camber. Uneven tire wear.	Replace axle. Replace oil seals. (Refer to Lubrication Section). Report to designated individual in authority. Report to designated individual in authority. Inflate tires properly. Check wheel alignment.



INDUSTRIAL TRUCK DIVISION



TROUBLE SHOOTING GUIDE

STEERING

TROUBLE	PROBABLE CAUSE	REMEDY
Steering difficult.	Lack of lubrication Tight steering system connections. Tight steering gear; misaligned wheels. Bent steering connecting linkage or arm. Misaligned steering gear mounting.	Lubricate. Lubricate and adjust linkage. Report to designated individual in authority. Straighten or replace linkage. Adjust mounting.
Wander or weaving.	Improper toe in camber or caster (axle twisted). Steering system connections or king pin bearings not properly lubricated. Loose wheel bearings. Steering gear worn or maladjusted. Steering gear mountings loose.	Report to designated individual in authority. Lubricate. Adjust wheel bearings. Report to designated individual in authority. Tighten mounting bolts.
Low speed shimmy or wobble.	Loose steering connections. Steering gear worn, or adjustment too loose. Loose wheel bearings.	Adjust and tighten linkage. Report to designated individual in authority. Adjust wheel bearings.
Vehicle pulls to one side.	Odd size, or new and old tires on opposite wheels. Tight wheel bearings. Bent steering arm or connection.	Match tires. Adjust. Lubricate wheel bearings. Straighten or replace bent linkage.





INDUSTRIAL TRUCK DIVISION



TROUBLE SHOOTING GUIDE

BRAKES

TROUBLE	PROBABLE CAUSE	REMEDY
Brakes drag.	<p>Improper pedal adjustment.</p> <p>Brake pedal return spring broken or weak.</p> <p>Brakes improperly adjusted.</p> <p>Brake shoe anchor pin tight in shoe.</p> <p>Brake shoe return spring broken or weak.</p> <p>Loose or damaged wheel bearings.</p> <p>Insufficient brake shoe clearance, or improper brake anchor pin adjustment.</p> <p>Brake backing plate loose.</p> <p>Grease on linings.</p> <p>Dirt imbedded in lining.</p> <p>Drums scored or rough.</p>	<p>Adjust brake pedal free travel.</p> <p>Replace spring.</p> <p>Adjust brakes.</p> <p>Free-up pin and lubricate lightly.</p> <p>Replace spring.</p> <p>Adjust or replace wheel bearings.</p> <p>Adjust brakes.</p> <p>Tighten plate.</p> <p>Correct grease leakage; clean or install new shoes and lining assemblies.</p> <p>Clean lining with wire brush.</p> <p>Replace drum and brake shoe and lining assemblies.</p>
Severe brake action on light pedal pressure.	<p>Brake shoes improperly adjusted.</p> <p>Grease on linings.</p> <p>Loose brake shoe anchor.</p>	<p>Adjust brakes.</p> <p>Correct grease leakage; clean or install new shoes and lining assemblies.</p> <p>Adjust and tighten.</p>
Brake locked.	<p>Brake pedal lacks free travel.</p> <p>Brakes frozen to drums (cold weather).</p>	<p>Adjust pedal free travel.</p> <p>Break loose by driving vehicle.</p>
Brake noisy or chatters.	<p>Brake lining worn.</p> <p>Grease on linings.</p> <p>Dirt embedded in linings.</p> <p>Improper or loose linings.</p> <p>Brake shoe or drum distorted.</p>	<p>Replace shoe and lining assemblies.</p> <p>Correct leakage; clean or replace shoe and lining assemblies.</p> <p>Clean lining with wire brush.</p> <p>Replace shoe and lining assemblies.</p> <p>Straighten or replace.</p>



INDUSTRIAL TRUCK DIVISION



TROUBLE SHOOTING GUIDE

BRAKES (Continued)

TROUBLE	PROBABLE CAUSE	REMEDY
Excessive pedal travel.	Lining worn. Brake improperly adjusted. Scored brake drums.	Adjust or replace shoe and lining assemblies. Adjust brake. Repair or replace drums.
Excessive pedal pressure.	Grease on linings; worn or glazed lining. Warped brake shoes, or defective brake linings. Shoes improperly adjusted. Brake drum scored or distorted. Shoes improperly adjusted. Insufficient fluid in master cylinder.	Correct grease leakage; clean up and replace shoe and lining assemblies. Replace shoe and lining assemblies. Adjust brakes. Repair or replace drums. Adjust brakes. Fill master cylinder to within 1/4 inch of the top.
Wheel troubles.	Wheel wobbles; bent. Wheel loose on hub. Wheel out of balance. Wheel bearings run hot.	Inspect mounting on hub, spindles, and drive axle; replace defective wheel or mounting. Tighten. Balance wheel. Adjust, lubricate wheel bearings.