

CLARK

**Industrial Truck
Division**

OPERATORS MANUAL

C 2 0 / 2 5 B

C 2 0 B P

C S 3 0

EFFECTIVE SERIAL NUMBERS

FIRST MACHINE OF LOT 625 THRU LAST MACHINE OF LOT 2169

Book No. 0-160-1 REV-2

Printing MAY 1982

Clark Equipment Company
Customer Service Publications Department
Battle Creek, Michigan 49016

SAFETY INSTRUCTIONS FOR MAINTAINING INDUSTRIAL TRUCKS

Powered industrial trucks may become hazardous if adequate maintenance is neglected. Therefore, adequate maintenance facilities, personnel and procedures should be provided.

Maintenance and inspection of all powered industrial trucks should be performed in conformance with the recommendation in this manual and the following practices.

1. A scheduled preventive maintenance, lubrication, and inspection system should be followed.
2. Only qualified and authorized personnel should be permitted to maintain, repair, adjust, and inspect industrial trucks.

3. Before Leaving The Truck:

- A. Stop truck.
- B. Fully lower the load engaging means.
- C. Place directional controls in neutral.
- D. Apply the parking brake.
- E. Stop the engine or turn off power.
- F. Lock the control or ignition circuit.
- G. Block the wheels if truck is on a ramp, or being worked on.

4. Before Working On Truck:

- A. Raise wheels free of floor or disconnect power source.
- B. Use chocks or other positive truck positioning devices.
- C. Block load engaging means, innermast(s), or chassis before working under them.

Before working on engine fuel system of gasoline powered trucks with gravity feed fuel systems, be sure fuel shutoff valve is closed.

Before working on engine fuel system of LP gas powered trucks, close LP gas cylinder valve and run engine until fuel in system is depleted and engine stops running.

Operation to check performance of the truck or attachments should be conducted in an authorized, safe clearance area.

5. Before Starting To Operate The Truck:

- A. Be in operating position.
- B. Depress clutch (or brake pedal on automatic transmission and electric trucks).
- C. Place directional controls in neutral.
- D. Start engine or turn on power.
- E. Before operating truck, check functioning of lift and tilt systems, directional and speed controls, steering, warning devices, brakes, and any attachment. (If used)
- F. Release parking brake.

- continued -

SAFETY INSTRUCTIONS FOR MAINTAINING INDUSTRIAL TRUCKS

6. Avoid fire hazards and have fire protection equipment present. Do not use an open flame to check level, or for leakage, of fuel, electrolyte or coolant. Do not use open pans of fuel or flammable cleaning fluids for cleaning parts.
7. Properly ventilate work area, vent exhaust fumes and keep shop clean and floor dry.
8. Handle LP gas cylinders with care. Do not drop, dent, or damage in any way.
9. Brakes, steering mechanisms, control mechanisms, warning devices, lights, governors, lift overload devices, guards and safety devices should be inspected regularly and maintained in a safe operating condition.
10. All parts of lift and tilt mechanisms and frame members should be carefully and regularly inspected and maintained in a safe operating condition.
11. Special trucks or devices designed and approved for hazardous area operation should receive special attention to ensure that maintenance preserves the original, approved safe operating features.
12. Fuel systems should be checked for leaks and condition of parts. Extra special consideration should be given in the case of a leak in the fuel system. Action should be taken to prevent the use of the truck until the leak has been corrected.
13. All hydraulic systems should be regularly inspected and maintained in conformance with good practice. Tilt cylinders, valves, and other similar parts should be checked to assure that "drift" has not developed to the extent that it would create a hazard.
14. Capacity, operation and maintenance instructions plates, tags, or decals should be maintained in legible condition.
15. Batteries, motors, controllers, limit switches, protective devices, electrical conductors and connections should be inspected and maintained in conformance with good practice. Special attention should be paid to the condition of electrical insulation.
16. Industrial trucks should be kept in a clean condition to minimize fire hazards and facilitate detection of loose or defective parts.
17. Modifications and additions which affect capacity and safe truck operation should not be performed by the customer or user without manufacturers prior written approval. Capacity, operation and maintenance instruction plates, tags or decals should be changed accordingly.
18. Care should be taken to assure that all replacement parts are interchangeable with the original parts and of a quality equal to that provided in the original equipment.



INDUSTRIAL TRUCK DIVISION



P L E A S E N O T E

I N S T R U C T I O N S O N U S E O F M A N U A L

This Operator's Manual is published as a service reference guide and includes Specifications, Operating Instructions, Lubrication and Preventive Maintenance Instructions, and Trouble Shooting Guide.

The TABLE OF CONTENTS for this manual is printed on green paper and is placed at the front for easy reference. A separate INDEX (also printed on green paper) is placed in front of the Lubrication and Preventive Maintenance Section.

Lubrication and Preventive Maintenance Instructions are listed under the TIME INTERVALS that they should be performed.

The TIME INTERVAL is part of the page number and code number.

Example: 8H 002-0; 8H is the TIME INTERVAL (8 operating hours), 002 is the PAGE NUMBER, and -0 is a CODE NUMBER that you as a customer should disregard. The dash number or code number is for the benefit of the publisher only.

The INDEX is set up under the TIME INTERVALS that the Lubrication and Preventive Maintenance should be performed.

Example: (8 Hours)	Time Interval & (H=Hours)	Page Number (000-)
Hydraulic Sump Tank, level check...	8H	503
Brake Pedal Free Travel, check.....	8H	303

The above states to check the sump tank fluid level every 8 operating hours and refer to page 503 for fluid recommendations etc. Also, to check brake pedal free travel at this interval and turn to page 303 for instructions.

Turn to the eight (8) hour section (8H) and then to the page listed — 503 or 303 etc. The instructions covered therein will pertain only to the checks or adjustments that should be performed at this TIME INTERVAL.

If, for instance, the Brake Pedal Free Travel is incorrect, you would then refer to the INDEX for "Brake Pedal Free Travel, adjust" which would be listed in the TIME INTERVALS following the 8 hour section.

<u>Example:</u> (100 Hours)	Time Interval & (H=Hours)	Page Number (000-)
Brake Pedal Free Travel, adjust....	100H	302

Turn to the one hundred hour section (100H) and then to



INDUSTRIAL TRUCK DIVISION



(continued)

I N S T R U C T I O N S O N U S E O F M A N U A L

page 302. Complete instructions as to the importance of pedal free travel, the method to check and adjust for correct free travel with illustrations are included therein.

N O T E

YOU WILL NOTE THAT AT THE BEGINNING OF EVERY SECTION A LUBRICATION AND PREVENTIVE MAINTENANCE ILLUSTRATION IS SHOWN GIVING THE LOCATION OF THE COMPONENTS TO BE SERVICED.

It is impossible to cover all types of machine operations in one manual. Operating conditions should determine the lubrication and maintenance intervals. Common sense and a close observance can best determine the frequency with which you should service your machine.

The care you give your machine will greatly determine the satisfaction and service life that you will obtain from it. A definite maintenance program should be set up and followed. Haphazard maintenance will only lead to faulty performance and short life.



INDUSTRIAL TRUCK DIVISION



TABLE OF CONTENTS

<u>Page</u>	<u>Description</u>
A001	Instruction On Use Of Manual
A003	Table Of Contents
B001	Illustration Of Machine
B003	Specifications
B031	New Machine 50 Hour Inspection

OPERATIONS

C002	Overall Controls
C003	Instrument Indicators
C103	Starting and Operating Instructions
C203	Fuel Tank Reserve Manual Cut-in Valve
C303	To Move, Stack and Lower Loads. Safety and Operating Suggestions
C401	Proper Handling of L.P. Fuel

LUBRICATION AND PREVENTIVE MAINTENANCE

<u>Time Interval & Number (H=Hours)</u>	<u>Page Number (0000-)</u>	<u>Description</u>
H	001	Index
8H	000	<u>8 Hour Lubrication and Preventive Maintenance Illustration</u>
8H	001	Horn, Fuel Tank and System Fuses
8H	003	Crankcase Oil Level check; Recommended Lubricants
8H	103	Cooling System check
8H	203	Instrument Indicators, check
8H	303	Brake Pedal Free Travel check; Parking Brake Operation check
8H	403	Engine Air Cleaner Service
8H	503	Hydraulic Sump Tank Level check; Hydraulic Control Lever Operation check
8H	602	Tires, inspect
100H	000	<u>100 Hour Lubrication and Preventive Maintenance Illustration</u>
100H	001	Converter Transmission and Axle Adaptor Level check; Fuel Tank and Lin inspect
100H	003	Engine Crankcase drain & refill; Crankcase Ventilation inspect, Engine Oil Filter change
100H	103	Cooling System inspect; clean radiator fins
100H	203	Fan and Generator Belt Adjustment
100H	302	Brake Pedal Free Travel check
100H	303	Brake Pedal Free Travel adjust; Master Cylinder level check
100H	403	Lift and Tilt Cylinders inspect; Lift Chains check and adjust; visually inspect all wiring and hydraulic piping; lubricate all miscellaneous linkage.
100H	503	Hydraulic Sump Tank Breather inspect
100H	603	Steering Gear verify lubricant level; Battery inspect
100H	702	Lubrication Charts
500H	000	<u>500 Hour Lubrication and Preventive Maintenance Illustration</u>
500H	001	Fuel Pump Strainer and Sediment Bowl clean; Fuel Pump Operation check
500H	003	Converter, Transmission and Axle Adaptor drain & refill; Transmission Fluid Filter change
500H	103	Hydraulic Sump Tank drain and refill; change filter element
500H	202	Steering Gear adjust
500H	302	Steering Axle and Linkage adjust
500H	403	Manifolds check security of mounting; Nuts, Bolts and Capscrews security check



INDUSTRIAL TRUCK DIVISION



TABLE OF CONTENTS

LUBRICATION AND PREVENTIVE MAINTENANCE

<u>Time Interval & Number (H-Hours)</u>	<u>Page (0000-)</u>	<u>Description</u>
1000H	000	<u>1000 Hour Lubrication and Preventive Maintenance Illustration</u>
1000H	001	Engine Tune Up; Air Cleaner, Fuel Pump service
1000H	003	Engine Tune Up; Cylinder Head Stud Nuts, Intake and Exhaust Manifolds, Crankcase Ventilation; Intake and Exhaust Valve Clearance adjust
1000H	004	Engine Tune Up; Intake and Exhaust Valve Clearance adjustments
1000H	103	Engine Tune Up; Compression test, Spark Plugs inspect
1000H	203	Engine Tune Up; Distributor
1000H	204	Engine Tune Up; Tach Dwell Meter
1000H	303	Engine Tune Up; Contact Point Adjustment
1000H	304	Ignition Timing
1000H	403	Engine Tune Up; Vacuum Test and Carburetor adjustment
1000H	503	Engine Tune Up; Governor adjustment
1000H	603	Starting Motor inspect
1000H	703	Generator inspect
1000H	803	Steering Wheel Bearings clean and repack; adjust
1000H	805	Axle Ends clean and repack
1000H	912	Bleeding Brake and inching system
1000H	1002	Brake adjustors
1000H	1103	Hand Brake adjustment
1000H	1202	Cooling System inspect and clean
1000H	1503	Main Hydraulic System Pressure checks
1000H	1703	Transmission Stall and Pressure checks
1000H	1793	Neutral Starting Switch
34M001A		Upright adjustments

TROUBLE SHOOTING GUIDE

<u>Page</u>	<u>Description</u>
TS 001	Engine
TS 251	Fuel System
TS 321	Cooling System
TS 341	Ignition System
TS 361	Starter
TS 381	Generator
TS 401	Battery & Horn
TS 483	Drive Axle
TS 521	Steering Axle
TS 541	Brake System
TS 653	Hydraulic System
TS 963	Hydratork Drive (Transmission)



INDUSTRIAL TRUCK DIVISION

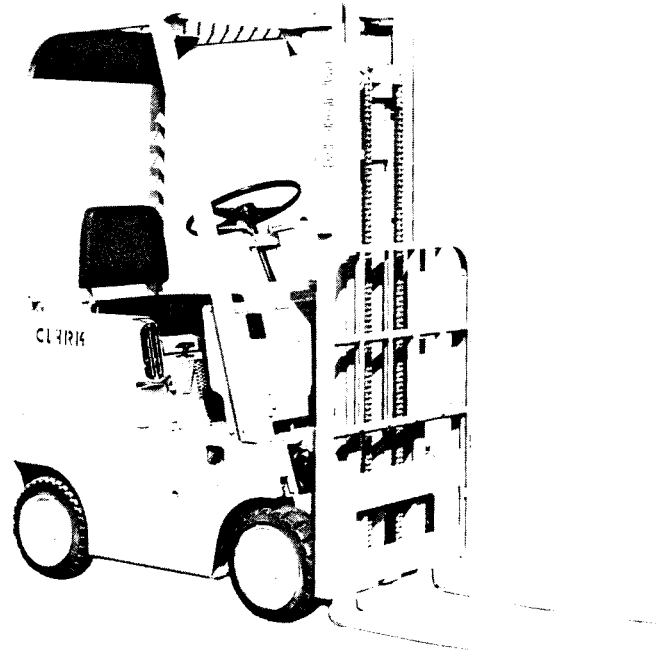

Plate 8085. C20B, C25B and CS30

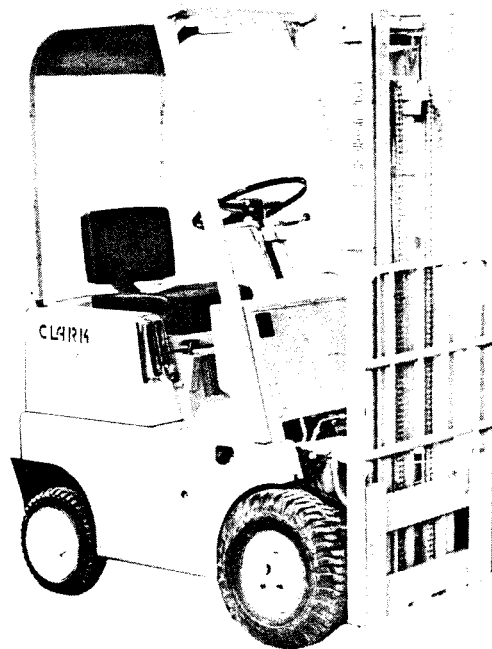

Plate 8086. C20BP

**ENGINEERING
SPECIFICATIONS**

CLARKLIFT® C 20
2,000 pounds capacity, 24 inch load center

	STANDARD	HI-LO	TSU
MODEL C 20 Service Weight	4,565 lbs.	4,600 lbs.	4,740 lbs.
Percent on drive wheels, truck empty:	54%		

APPROVED INSURANCE CLASSIFICATIONS. The following industrial truck classifications for this model are approved and listed by Underwriters' Laboratory and Factory Mutual: Type G; GS; LP; and LPS.

DIMENSIONS

Length (to front face of forks)	69½"	Tread, steer	27½"
Wheelbase	44"	Turning radius	62"
Width, standard	32"	Basic aisle for right angle stacking (add load length)	72¾"
Tread, drive	26"		

UNDERCLEARANCES

Upright	3"	Steer axle	3¾"
Drive axle	3"	Center of frame	4½"
		Counterweight	4"

SPEEDS AND GRADES

Travel speeds with rated load	10.8 MPH (950 FPM)
Gradeability with rated load	23.8%

	STANDARD		HI-LO		TSU	
	Loaded	Empty	Loaded	Empty	Loaded	Empty
Lifting speed (FPM)	83	94	62	70	64	72
Lowering speed (FPM)	60	80	60	65	60	80

ENGINE. Industrial Continental Red Seal, 4 cylinder, "L" head, equipped with stellite-faced valves; seats, positive valve rotators. Connecting rods, main bearings, cam shaft and timing gears are pressure lubricated by submerged gear-type pump. Mechanical governor controls engine speed accurately without choking off power. Updraft carburetor incorporates design features for minimum carbon monoxide emission.

Model	Y 112
Bore	3¾"
Stroke	3½"
Displacement, cu. inches	112
Crankcase Capacity, quarts	3½
Governed RPM with no load	2350
SAE rated horsepower at 2350 RPM	33
Maximum SAE torque, lb. foot at 1400 RPM	88
Fuel tank capacity, gallons	5½

ENGINE FILTERS. Three types: (1) Fuel filter in metallic bowl. (2) One pint oil filter with automotive-type replaceable cartridge. (3) Enclosed dry type intake air filter that uses a replaceable pleated paper cartridge with minute 5-micron openings. Directional air intake draws fresh air from outside the engine compartment through air scoops.

ELECTRICAL SYSTEM. 12-volt, 45 amp-hour battery. 25 amp low cut-in generator charges at idle. Other features include an enclosed electric starter motor with positive engagement and electrical cut-out; weather-shielded key starting switch; dust-proof distributor; electric horn. Multiple disconnect plug to instrument panel simplifies servicing.

INSTRUMENTS. Direct reading engine hour meter mounted on left-hand side above gas fill compartment. Ammeter, engine oil pressure light, fuel and temperature gauges all mounted in cowl, for easy reading.

AXLE AND FINAL DRIVE. Integral assembly with 3-point mounting including engine, torque converter, transmission, spiral bevel pinion and ring gear, differential and full floating drive axle assembly. Axle housing carries weight of truck, not drive shaft. Final gear reduction is made through fully enclosed pinion and ring gear at drive wheels.

HYDRATORK TRANSMISSION. Power-shifted constant mesh transmission and torque converter multiply engine torque without punishing "shock" on drive shaft and gears. Oil is cooled through separate cooler in bottom of radiator and is filtered through one pint automotive type replaceable cartridge filter. Direction selector lever for left-hand finger-tip control on steering column.

HYDRAULIC INCHING. In close quarters the "free pedal" portion of the left inching-brake pedal hydraulically actuates inching valve permitting power to be gradually disengaged from drive wheels, even when engine is running at top speed for fast lifting.

BRAKES. Right-foot brake pedal actuates brakes only. Self-adjusting shoes require no adjustment for life of lining. Foot brake torque multiplied through final reduction at each drive wheel, reduces pedal effort, increases brake life. Hydraulic internal expanding double shoe has bonded lining. Brake shoes and drums are enclosed within drive axle housing instead of inside drive wheels. Mechanical "V" block parking brake operates on transmission drive shaft.

STEERING. Large rear steer tires are equal in diameter to drive tires for a more comfortable ride, easier steering, and ability to negotiate rough surfaces. Steering also made easier by reduced weight on steer wheels, due to longer wheel base. Strong vanadium steel steer axle is mounted on two torsional rubber bushings to cushion shock and provide articulation up to 3". Positive stops for lateral stability. Inclined king pins for anti-kickback control. Recirculating ball type steering gear with 18" diameter steering handwheel. Accurate center point steering geometry. Tie rods are automotive type.

HYDRAULIC SYSTEM. Full feathering balanced spool type valves for gentle starts and stops. Built-in pressure relief valve protects system against overloads. Vane-type pump is driven by hardened gears. Hydraulic sump, built into frame of ¾" thick plate has 2.8 gallons capacity. Flexible rubber hydraulic hose lines are steel braid reinforced. System is protected from dirt by (1) a 5-micron pleated replacement filler cap breather (2) a 25-micron full flow filter in sump.

SEATING. Rubber mounted wide seat and backrest are Polyurethane foam, covered with vinyl plastic. Backrest is contoured and center pivoted to fit position of driver, reducing driver fatigue. Automotive-type latch releases the seat for horizontal adjustment up to 3".

MAINTENANCE. Split swing-out hood offers easy access for servicing. Check-points such as water and hydraulic sump filler caps, oil dip-stick and filler readily accessible. Battery tray swings out. Quickly detachable counterweights are hook mounted, secured with one large bolt.

OVERHEAD GUARD AND LOAD BACKREST. Driver's overhead guard and 48" high load backrest are standard equipment.

ADDED ADVANTAGES. Protectoseal gas tank filler cap; auxiliary fuel supply of ½ gallon; recessed pin-type coupler at 12"; multi-pass muffler; bolts and screws are zinc or cadmium plated; all exposed surfaces are shot-blasted and prime painted with weather-resistant paint.

COLORS. Standard delivery color is two-tone silver-grey and yellow; optional colors with grey are red, orange, green and blue.

**DIMENSIONAL
SPECIFICATIONS**

CLARKLIFT® C 20

2,000 pounds capacity, 24 inch load center

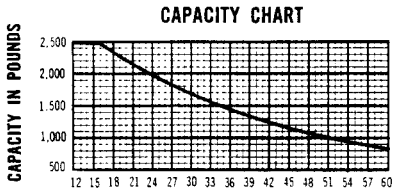

Load center in inches from front face of forks — Rated capacities shown above are computed with uprights in vertical position. They apply only on uprights with maximum fork heights up to and including 154"

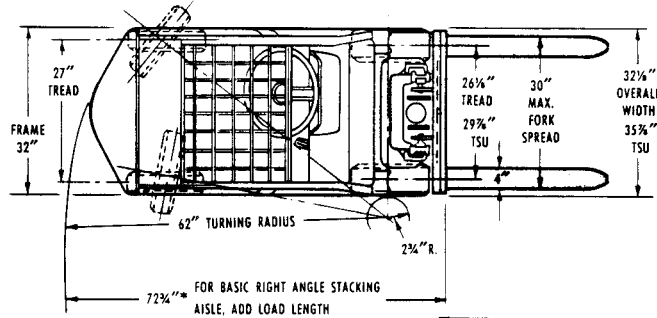

UPRIGHT DIMENSION TABLE

MFH			FREELIFT		
STD. HI-LO	STD. & FFL TSU	OVERALL HEIGHT LOWERED	STD.	HI-LO & FFL TSU	TSU
70	—	53	18	—	—
76	—	56	18	—	—
82	—	59	18	—	—
88	—	62	18	—	—
94	135	65	18	45	12 1/2
100	144	68	18	48	12 1/2
106	153	71	18	51	12 1/2
112	162	74	18	54	12 1/2
118	171	77	18	57	12 1/2
124	180	80	18	60	12 1/2
130	189	83	18	63	12 1/2
136	198	86	18	66	12 1/2
142	207	89	18	69	12 1/2
148	216	93	18	73	12 1/2
154	225	96	18	76	12 1/2
160	—	99	18	79	—
166	—	103	18	83	—
172	—	106	18	86	—
178	—	109	18	89	—

For overall height raised, less load backrest, add 20 1/2" to maximum fork height.

GRADE & DRAWBAR PULL CHART

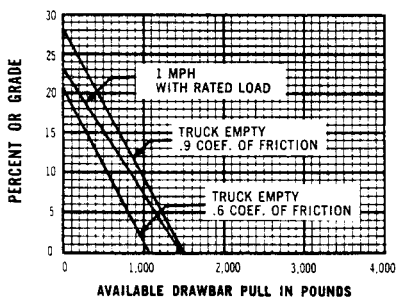

AVAILABLE DRAWBAR PULL IN POUNDS
With towing coupler 12" from floor

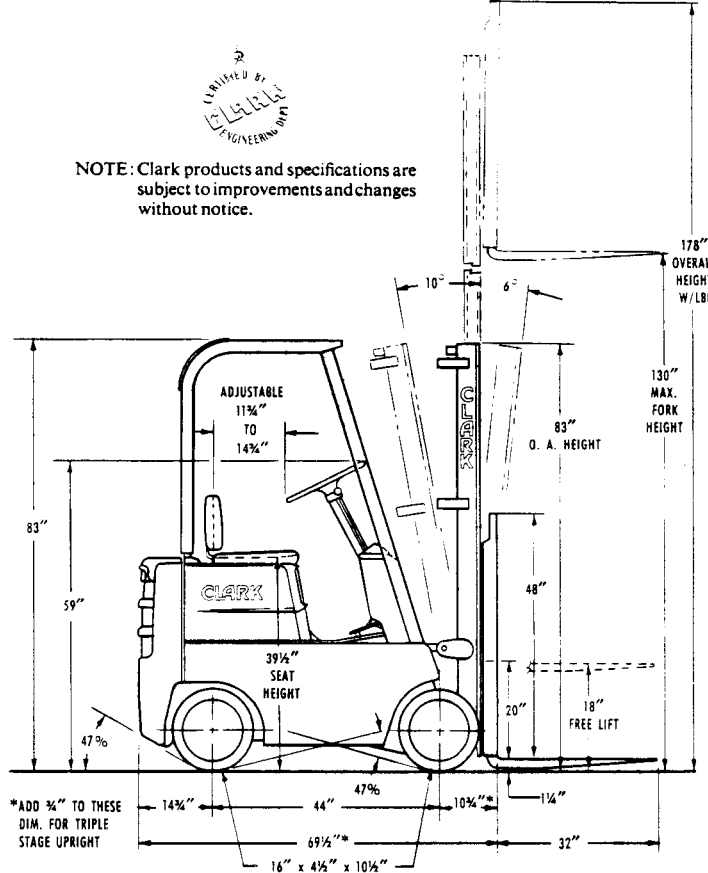

*ADD 3/4" TO THESE DIM. FOR TRIPLE STAGE UPRIGHT



NOTE: Clark products and specifications are subject to improvements and changes without notice.

Industrial Truck Division
Battle Creek, Michigan

GAS/DIESEL/ELECTRIC FORK LIFTS
ELECTRIC NARROW AISLE TRUCKS
ELECTRIC HAND TRUCKS/STRADDLE CARRIERS
TOWING TRACTORS/COMPLETE LINE OF HANDLING DEVICES

SS21515ME

PRINTED IN U.S.A.

**ENGINEERING
SPECIFICATIONS**

CLARKLIFT® C 25
2,500 pounds capacity, 24 inch load center

	STANDARD	HI-LO	TSU
MODEL C 25 Service Weight	5,048 lbs.	5,088 lbs.	5,223 lbs.
Percent on drive wheels, truck empty:	45%		

APPROVED INSURANCE CLASSIFICATIONS. The following industrial truck classifications for this model are approved and listed by Underwriters' Laboratory and Factory Mutual: Type G; GS; LP; and LPS.

DIMENSIONS

Length (to front face of forks)	71¾"	Tread, steer	27½"
Wheelbase	44"	Turning radius	64"
Width, standard	33½"	Basic aisle for right angle stacking (add load length)	75"
Tread, drive	27½"		

UNDERCLEARANCES

Upright	3"	Center of frame	5½"
Drive axle	3"	Counterweight	4"
Steer axle	3¾"	Grade Clearance	45%

SPEEDS AND GRADES

Travel speeds with rated load	10.8 MPH (950 FPM)
Gradeability with rated load	20.6%

	STANDARD		HI-LO		TSU	
	Loaded	Empty	Loaded	Empty	Loaded	Empty
Lifting speed (FPM)	83	94	62	70	64	72
Lowering speed (FPM)	60	80	60	65	60	80

ENGINE. Industrial Continental Red Seal, 4 cylinder, "L" head, equipped with stellite-faced valves; seats, positive valve rotators. Connecting rods, main bearings, cam shaft and timing gears are pressure lubricated by submerged gear-type pump. Mechanical governor controls engine speed accurately without choking off power. Updraft carburetor incorporates design features for minimum carbon monoxide emission.

Model	Y 112
Bore	3¾"
Stroke	3½"
Displacement, cu. inches	112
Crankcase Capacity, quarts	3½
Governed RPM with no load	2350
SAE rated horsepower at 2350 RPM	33
Maximum SAE torque, lb. foot at 1400 RPM	88
Fuel tank capacity, gallons	5½

ENGINE FILTERS. Three types: (1) Fuel filter in metallic bowl. (2) One pint oil filter with automotive-type replaceable cartridge. (3) Enclosed dry type intake air filter that uses a replaceable pleated paper cartridge with minute 5-micron openings. Directional air intake draws fresh air from outside the engine compartment through air scoops.

ELECTRICAL SYSTEM. 12-volt, 45 amp-hour battery. 25 amp low cut-in generator charges at idle. Other features include an enclosed electric starter motor with positive engagement and electrical cut-out; weather-shielded key starting switch; dust-proof distributor; electric horn. Multiple disconnect plug to instrument panel simplifies servicing.

INSTRUMENTS. Direct reading engine hour meter mounted on left-hand side above gas fill compartment. Ammeter, engine oil pressure light, fuel and temperature gauges all mounted in cowl, for easy reading.

AXLE AND FINAL DRIVE. Integral assembly with 3-point mounting including engine, torque converter, transmission, spiral bevel pinion and ring gear, differential and full floating drive axle assembly. Axle housing carries weight of truck, not drive shaft. Final gear reduction is made through fully enclosed pinion and ring gear at drive wheels.

HYDRATORK TRANSMISSION. Power-shifted constant mesh transmission and torque converter multiply engine torque without punishing "shock" on drive shaft and gears. Oil is cooled through separate cooler in bottom of radiator and is filtered through one pint automotive type replaceable cartridge filter. Direction selector lever for left-hand finger-tip control on steering column.

HYDRAULIC INCHING. In close quarters the "free pedal" portion of the left inching-brake pedal hydraulically actuates inching valve permitting power to be gradually disengaged from drive wheels, even when engine is running at top speed for fast lifting.

BRAKES. Right-foot brake pedal actuates brakes only. Self-adjusting shoes require no adjustment for life of lining. Foot brake torque multiplied through final reduction at each drive wheel, reduces pedal effort, increases brake life. Hydraulic internal expanding double shoe has bonded lining. Brake shoes and drums are enclosed within drive axle housing instead of inside drive wheels. Mechanical "V" block parking brake operates on transmission drive shaft.

STEERING. Large rear steer tires are equal in diameter to drive tires for a more comfortable ride, easier steering, and ability to negotiate rough surfaces. Steering also made easier by reduced weight on steer wheels, due to longer wheel base. Strong vanadium steel steer axle is mounted on two torsional rubber bushings to cushion shock and provide articulation up to 3". Positive stops for lateral stability. Inclined king pins for anti-kickback control. Recirculating ball type steering gear with 18" diameter steering handwheel. Accurate center point steering geometry. Tie rods are automotive type.

HYDRAULIC SYSTEM. Full feathering balanced spool type valves for gentle starts and stops. Built-in pressure relief valve protects system against overloads. Vane-type pump is driven by hardened gears. Hydraulic sump, built into frame of ¾" thick plate has 2.8 gallons capacity. Flexible rubber hydraulic hose lines are steel braid reinforced. System is protected from dirt by (1) a 5-micron pleated replacement filler cap breather (2) a 25-micron full flow filter in sump.

SEATING. Rubber mounted wide seat and backrest are Polyurethane foam, covered with vinyl plastic. Backrest is contoured and center pivoted to fit position of driver, reducing driver fatigue. Automotive-type latch releases the seat for horizontal adjustment up to 3".

MAINTENANCE. Split swing-out hood offers easy access for servicing. Check-points such as water and hydraulic sump filler caps, oil dip-stick and filler readily accessible. Battery tray swings out. Quickly detachable counterweights are hook mounted, secured with one large bolt.

OVERHEAD GUARD AND LOAD BACKREST. Driver's overhead guard and 48" high load backrest are standard equipment.

ADDED ADVANTAGES. Protectoseal gas tank filler cap; auxiliary fuel supply of ½ gallon; recessed pin-type coupler at 12"; multi-pass muffler; bolts and screws are zinc or cadmium plated; all exposed surfaces are shot-blasted and prime painted with weather-resistant paint.

COLORS. Standard delivery color is two-tone silver-grey and yellow; optional colors with grey are red, orange, green and blue.

**DIMENSIONAL
SPECIFICATIONS**

CLARKLIFT® C 25
2,500 pounds capacity, 24 inch load center

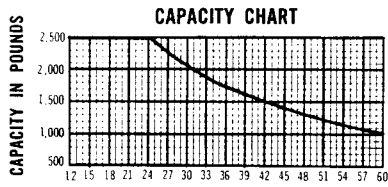

Load center in inches from front face of forks — They apply only on maximum fork heights up to and including 145" with standard upright or 153" with TSU.

UPRIGHT DIMENSION TABLE

MFH			FREELIFT		
STD. HI-LO	STD. & FF TSU	OVERALL HEIGHT LOWERED	STD.	HI-LO & FL TSU	TSU
70	—	53	18	—	—
76	—	56	18	—	—
82	—	59	18	—	—
88	—	62	18	—	—
94	135	65	18	45	12½
100	144	68	18	48	12½
106	153	71	18	51	12½
112	162	74	18	54	12½
118	171	77	18	57	12½
124	180	80	18	60	12½
130	189	83	18	63	12½
136	198	86	18	66	12½
142	207	89	18	69	12½
148	216	93	18	73	12½
154	225	96	18	76	12½
160	—	99	18	79	—
166	—	103	18	83	—
172	—	106	18	86	—
178	—	109	18	89	—

For overall height raised, less load backrest, add 20½" to maximum fork height.

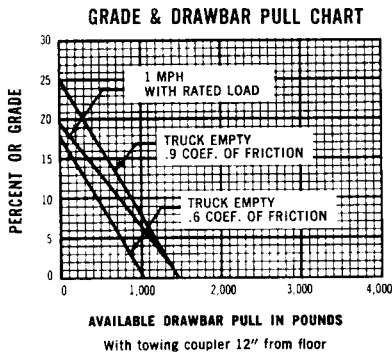

AVAILABLE DRAWBAR PULL IN POUNDS
With towing coupler 12" from floor

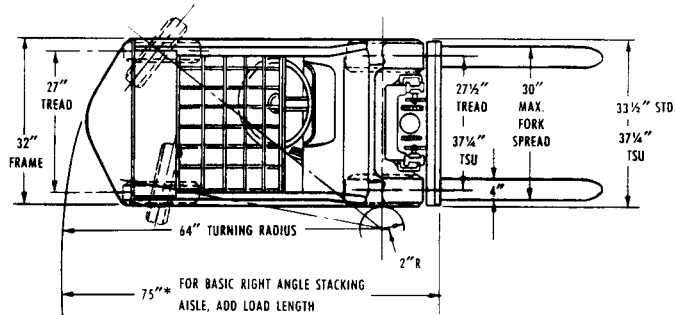

NOTE: Clark products and specifications are subject to improvements and changes without notice.

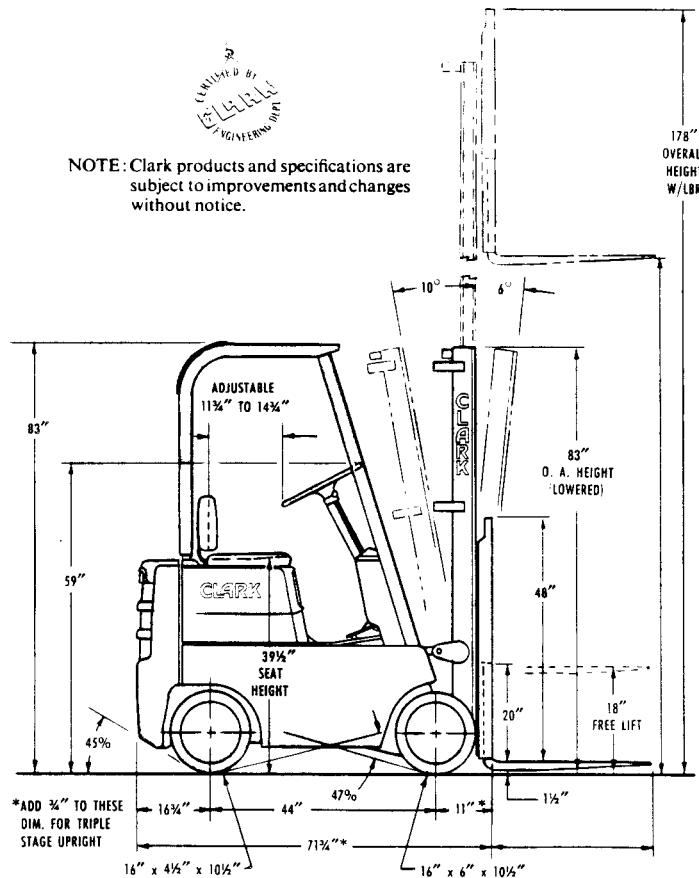

Industrial Truck Division
Battle Creek, Michigan

GAS/DIESEL/ELECTRIC FORK LIFTS
ELECTRIC NARROW AISLE TRUCKS
ELECTRIC HAND TRUCKS/STRADDLE CARRIERS
TOWING TRACTORS/COMPLETE LINE OF HANDLING DEVICES

SS21615ME

PRINTED IN U.S.A.



INDUSTRIAL TRUCK DIVISION



SPECIFICATIONS

ENGINEERING SPECIFICATIONS

CLARKLIFT® C 20P

2,000 pounds capacity, 24 inch load center
Pneumatic drive tires, cushion steer tires.

	STANDARD	HI-LO	TSU
MODEL C 20P Service Weight	4,918 lbs.	4,958 lbs.	5,093 lbs.
Percent on drive wheels, truck empty:	45%		

APPROVED INSURANCE CLASSIFICATIONS. The following industrial truck classifications for this model are approved and listed by Underwriters' Laboratory and Factory Mutual: Type G; GS; LP; and LPS.

DIMENSIONS

Length (to front face of forks)	74 ³ / ₄ "	Tread, steer	27 ¹ / ₂ "
Wheelbase	44 ¹ / ₄ "	Turning radius	64"
Width, standard	36"	Basic aisle for right angle stacking (add load length)	77 ³ / ₄ "
Tread, drive	29 ³ / ₄ "		

UNDERCLEARANCES

Upright	3 ¹ / ₂ "	Steer axle	3 ³ / ₄ "
Drive axle	5 ¹ / ₄ "	Center of frame	6 ³ / ₄ "
		Counterweight	6 ¹ / ₄ "
		Grade Clearance	7 ³ / ₈ "

SPEEDS AND GRADES

Travel speeds with rated load	11 MPH
Gradeability with rated load	20.7%

	STANDARD		HI-LO		TSU	
	Loaded	Empty	Loaded	Empty	Loaded	Empty
Lifting speed (FPM)	83	94	62	70	64	72
Lowering speed (FPM)	60	80	60	65	60	80

ENGINE. Industrial Continental Red Seal, 4 cylinder, "L" head, equipped with stellite-faced valves; seats, positive valve rotators. Connecting rods, main bearings, cam shaft and timing gears are pressure lubricated by submerged gear-type pump. Mechanical governor controls engine speed accurately without choking off power. Updraft carburetor incorporates design features for minimum carbon monoxide emission.

Model	Y 112
Bore	3 ³ / ₁₆ "
Stroke	3 ¹ / ₂ "
Displacement, cu. inches	112
Crankcase Capacity, quarts	3 ¹ / ₂
Governed RPM with no load	2350
SAE rated horsepower at 2350 RPM	33
Maximum SAE torque, lb. foot at 1400 RPM	88
Fuel tank capacity, gallons	5 ¹ / ₂

ENGINE FILTERS. Three types: (1) Fuel filter in metallic bowl. (2) One pint oil filter with automotive-type replaceable cartridge. (3) Enclosed dry type intake air filter that uses a replaceable pleated paper cartridge with minute 5-micron openings. Directional air intake draws fresh air from outside the engine compartment through air scoops.

ELECTRICAL SYSTEM. 12-volt, 45 amp-hour battery. 25 amp low cut-in generator charges at idle. Other features include an enclosed electric starter motor with positive engagement and electrical cut-out; weather-shielded key starting switch; dust-proof distributor; electric horn. Multiple disconnect plug to instrument panel simplifies servicing.

INSTRUMENTS. Direct reading engine hour meter mounted on left-hand side above gas fill compartment. Ammeter, engine oil pressure light, fuel and temperature gauges all mounted in cowl, for easy reading.

AXLE AND FINAL DRIVE. Integral assembly with 3-point mounting including engine, torque converter, transmission, spiral bevel pinion and ring gear, differential and full floating drive axle assembly. Axle housing carries weight of truck, not drive shaft. Final gear reduction is made through fully enclosed pinion and ring gear at drive wheels.

HYDRATORK TRANSMISSION. Power-shifted constant mesh transmission and torque converter multiply engine torque without punishing "shock" on drive shaft and gears. Oil is cooled through separate cooler in bottom of radiator and is filtered through one pint automotive type replaceable cartridge filter. Direction selector lever for left-hand finger-tip control on steering column.

HYDRAULIC INCHING. In close quarters the "free pedal" portion of the left inching-brake pedal hydraulically actuates inching valve permitting power to be gradually disengaged from drive wheels, even when engine is running at top speed for fast lifting.

BRAKES. Right-foot brake pedal actuates brakes only. Self-adjusting shoes require no adjustment for life of lining. Foot brake torque multiplied through final reduction at each drive wheel, reduces pedal effort, increases brake life. Hydraulic internal expanding double shoe has bonded lining. Brake shoes and drums are enclosed within drive axle housing instead of inside drive wheels. Mechanical "V" block parking brake operates on transmission drive shaft.

STEERING. Large rear steer tires are equal in diameter to drive tires for a more comfortable ride, easier steering, and ability to negotiate rough surfaces. Steering also made easier by reduced weight on steer wheels, due to longer wheel base. Strong vanadium steel steer axle is mounted on two torsional rubber bushings to cushion shock and provide articulation up to 3". Positive stops for lateral stability. Inclined king pins for anti-kickback control. Recirculating ball type steering gear with 18" diameter steering handwheel. Accurate center point steering geometry. Tie rods are automotive type.

HYDRAULIC SYSTEM. Full feathering balanced spool type valves for gentle starts and stops. Built-in pressure relief valve protects system against overloads. Vane-type pump is driven by hardened gears. Hydraulic sump, built into frame of ³/₈" thick plate has 2.8 gallons capacity. Flexible rubber hydraulic hose lines are steel braid reinforced. System is protected from dirt by (1) a 5-micron pleated replacement filler cap breather (2) a 25-micron full flow filter in sump.

SEATING. Rubber mounted wide seat and backrest are Polyurethane foam, covered with vinyl plastic. Backrest is contoured and center pivoted to fit position of driver, reducing driver fatigue. Automotive-type latch releases the seat for horizontal adjustment up to 3".

MAINTENANCE. Split swing-out hood offers easy access for servicing. Check-points such as water and hydraulic sump filler caps, oil dip-stick and filter readily accessible. Battery tray swings out. Quickly detachable counterweights are hook mounted, secured with one large bolt.

OVERHEAD GUARD AND LOAD BACKREST. Driver's overhead guard and 48" high load backrest are standard equipment.

ADDED ADVANTAGES. Protectoseal gas tank filler cap; auxiliary fuel supply of 1/2 gallon; recessed pin-type coupler at 12"; multi-pass muffler; bolts and screws are zinc or cadmium plated; all exposed surfaces are shot-blasted and prime painted with weather-resistant paint.

COLORS. Standard delivery color is two-tone silver-grey and yellow; optional colors with grey are red, orange, green and blue.

**DIMENSIONAL
SPECIFICATIONS**

CLARKLIFT® C 20P

2,000 pounds capacity, 24 inch load center
Pneumatic drive tires, cushion steer tires.

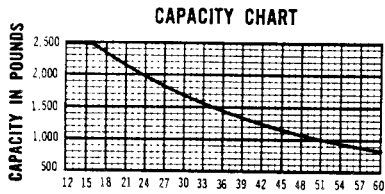

Load center in inches from front face of forks —
They apply only on maximum fork heights up to
and including 145" with standard upright or 153"
with TSU.

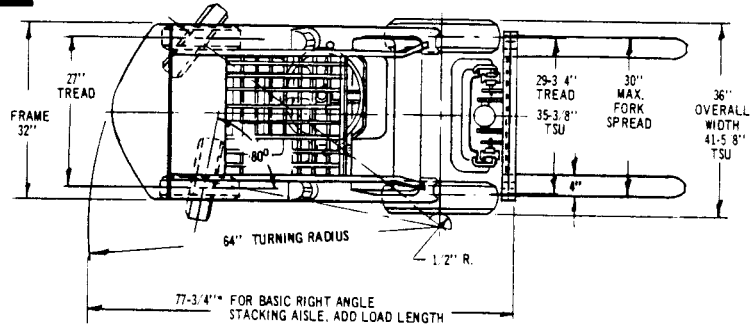

UPRIGHT DIMENSION TABLE

MFH			FREELIFT		
STD. HI-LO	STD. & FF TSU	OVERALL HEIGHT LOWERED	STD.	HI-LO & FL TSU	TSU
70	—	53	18	—	—
76	—	56	18	—	—
82	—	59	18	—	—
88	—	62	18	—	—
94	135	65	18	45	—
100	144	68	18	48	12 1/2
106	153	71	18	51	12 1/2
112	162	74	18	54	12 1/2
118	171	77	18	57	12 1/2
124	180	80	18	60	12 1/2
130	189	83	18	63	12 1/2
136	198	86	18	66	12 1/2
142	207	89	18	69	12 1/2
148	216	93	18	73	12 1/2
154	225	96	18	76	12 1/2
160	—	99	18	79	—
166	—	103	18	83	—
172	—	106	18	86	—
178	—	109	18	89	—

For overall height raised, less load backrest, add
20 1/2" to maximum fork height.

GRADE & DRAWBAR PULL CHART

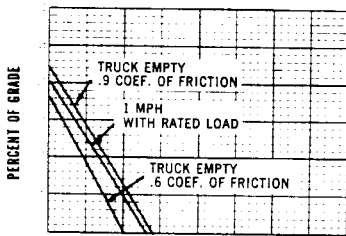

AVAILABLE DRAWBAR PULL IN POUNDS
With towing coupler 12" from floor

Industrial Truck Division
Battle Creek, Michigan

GAS DIESEL ELECTRIC FORK LIFTS
ELECTRIC NARROW AISLE TRUCKS
ELECTRIC HAND TRUCKS STRADDLE CARRIERS
TOWING TRACTORS COMPLETE LINE OF HANDLING DEVICES

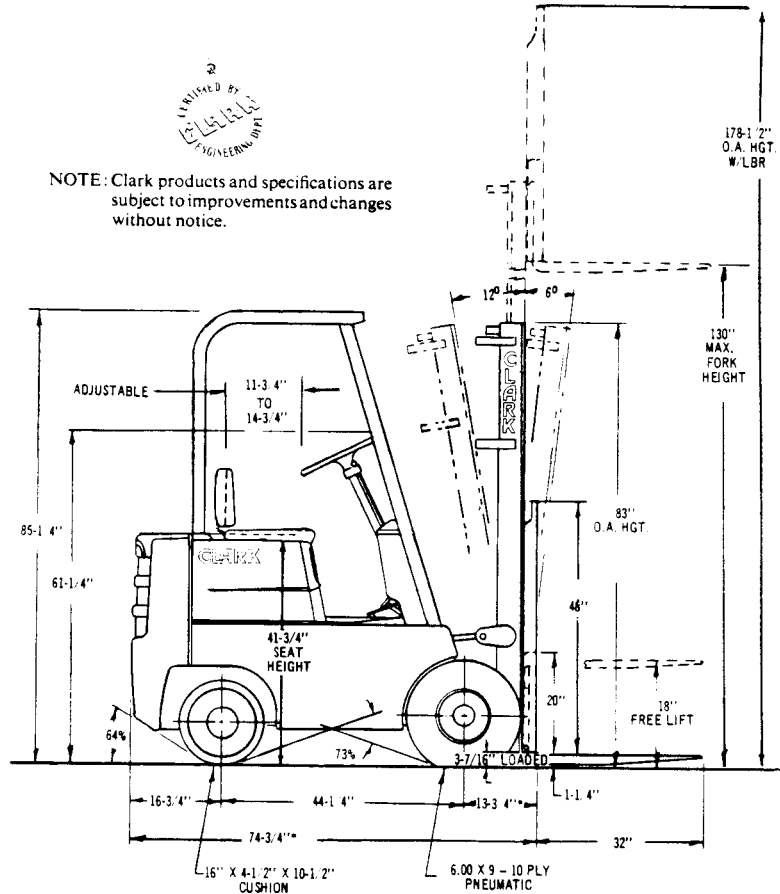

*ADD 1" TO THESE DIM. FOR TRIPLE STAGE UPRIGHT



NOTE: Clark products and specifications are
subject to improvements and changes
without notice.

ENGINEERING
SPECIFICATIONS

CLARKLIFT® CS 30

3,000 pounds capacity, 24 inch load center

MODEL CS 30	130" STD.	130" HI-LO	130" FFL/TSU
Service Weight	5,775	5,835	6,040
Weight on Drive Wheels - Empty	2,190	2,260	2,355
Weight on Drive Wheels - Loaded	7,657	7,727	7,880

INSURANCE CLASSIFICATIONS: Underwriters' Laboratories, Inc. listed and Factory Mutual approved. Type G or LP standard. GS or LPS optional.

SPEEDS AND GRADES	HYDRATORK CS 30		
	STD.	HI-LO	FFL/TSU
Std. travel speed - Loaded	66	62	62
Std. gradeability @ .9 c.f. - Loaded	87	70	70
Optional travel speed - Loaded	60	60	60
Gradeability @ .9 c.f. - Empty	80	65	80
Drawbar pull @ .9 c.f. - Empty	1800 lbs.		

ENGINE: Industrial Continental Red Seal, 4 cylinder, "L" head, equipped with stellite-faced valves; seats, positive valve rotators. Connecting rods, main bearings, camshaft and timing gears are pressure lubricated by submerged gear-type pump. Mechanical governor controls engine speed accurately without choking off power. Updraft carburetor incorporates design features to reduce carbon monoxide emission.

Model	Y 112
Bore	3 ⁹ / ₁₆ "
Stroke	3 ¹ / ₂ "
Displacement, cu. in.	112
Crankcase capacity, qts.	3 ¹ / ₂
Governed RPM with no load	2350
SAE rated horsepower at 2350 RPM	33
Maximum SAE torque, lb. ft. at 1400 RPM	88
Fuel tank capacity, gals.	5 ¹ / ₂

ENGINE FILTERS: Three types: (1) Fuel filter in metallic bowl. (2) One pint oil filter with automotive-type replaceable cartridge. (3) Enclosed dry type intake air filter that uses a replaceable pleated paper cartridge with minute 5-micron openings. Directional air intake draws fresh air from outside the engine compartment through air scoops.

ELECTRICAL SYSTEM: 12-volt, 46 amp-hour battery. 25 amp low cut-in generator charges at idle. Other features include an enclosed electric starter motor with positive engagement and electrical cut-out; weather-shielded key starting switch; dustproof distributor; electric horn. Multiple disconnect plug to instrument panel simplifies servicing.

INSTRUMENTS: Direct reading engine hour meter mounted on left hand side above gas fill compartment. Ammeter, engine oil pressure light, fuel and temperature gauges all mounted in cowl, for easy reading.

AXLE AND FINAL DRIVE: Integral assembly with 3-point mounting including engine, torque converter, transmission, spiral bevel pinion and ring gear, differential and full floating drive axle assembly. Axle housing carries weight of truck, not drive shaft. Final gear reduction is through fully enclosed pinion and ring gear at drive wheels.

HYDRATORK® TRANSMISSION: Power-shift, constant mesh transmission and torque converter multiply engine torque without punishing "shock" on drive shaft and gears. Oil is cooled through separate cooler in bottom of radiator and is filtered through one pint automotive-type replaceable cartridge filter. Direction selector lever for left hand fingertip control on steering column.

HYDRAULIC INCHING: In close quarters the "free pedal" portion of the left inching-brake pedal hydraulically actuates inching valve permitting power to be gradually disengaged from drive wheels, even when engine is running at top speed for fast lifting.

STANDARD UPRIGHT ASSEMBLY: Full roller upright, constructed with interlocking "I" beams and channel rails. Four, canted, variable retainment, upright rollers and four, canted, carriage rollers along with two, lateral thrust, carriage rollers bearing on the outside of the inner rails - minimize the "I" beam deflection and rail spreading caused by off-center loading. Rollers packed with waterproof grease and lifetime sealed. Inner and outer rails reinforced with heavy tie bars. Rollers shim adjustable without disassembly of upright rails. Chrome plated tilt cylinder rods. Anti-cavitation valve to prevent hydraulic voids in tilt cylinders. Urethane wiper rings on lift and tilt cylinders. Heavy duty, bar type carriage. Upset-forged and heat treated forks have full section strength at the heel and positive fork retainers. Free floating lift cylinder mount. Modulating flow control valve reduces lowering speed as load weight increases. Lift chains are held within their sheaves by retaining pins.

BRAKES: Right foot brake pedal actuates brakes only. Self-adjusting shoes require no adjustment for life of lining. Foot brake torque multiplied through final reduction at each drive wheel, reduces pedal effort, increases brake life. Hydraulic internal expanding double shoe has bonded lining. Brake shoes and drums are enclosed within drive axle housing instead of inside drive wheels. Mechanical "V" block parking brake operates on transmission drive shaft.

STEERING: Large rear steer tires are equal in diameter to drive tires for a more comfortable ride, easier steering, and ability to negotiate rough surfaces. Strong vanadium steel steer axle is mounted on two torsional rubber bushings to cushion shock and provide articulation up to 3". Positive stops for lateral stability. Inclined king pins for anti-kickback control. Recirculating ball type steering gear with 18" diameter steering handwheel. Accurate center point steering geometry. Tie rods are automotive type.

HYDRAULIC SYSTEM: Full feathering balanced spool type valves for gentle starts and stops. Built-in pressure relief valve protects system against overloads. Vane-type pump is driven by hardened gears. Hydraulic sump, built into frame of ³/₈" thick plate has 2.8 gallons capacity. Flexible rubber hydraulic hose lines are steel braid reinforced. System is protected from dirt by (1) a 5-micron pleated replacement filler cap breather (2) a 25-micron full flow filter in sump.

SEATING: Rubber mounted wide seat and backrest are Polyurethane foam, covered with vinyl plastic. Backrest is contoured and center pivoted to fit position of driver, reducing driver fatigue. Automotive-type latch releases the seat for horizontal adjustment up to 3".

MAINTENANCE: Split swing-out hood offers easy access for servicing. Checkpoints such as water and hydraulic sump filler caps, oil dipstick and filler readily accessible. Battery tray swings out. Quickly detachable counterweights are hook mounted, secured with one large bolt.

OVERHEAD GUARD AND LOAD BACKREST EXTENSION: Overhead guard and 48" high load backrest extension are standard equipment.

ADDED ADVANTAGES: Protectoseal gas tank filler cap; auxiliary fuel supply of ¹/₂ gallon; recessed pin-type coupler at 12"; multi-pass muffler; bolts and screws are zinc or cadmium plated.

PAINT: Exposed surfaces are shot-blasted, primed and painted with weather resistant paint. Standard color is Clark Green with yellow wheel rims. Optional colors are solid yellow or orange.

DIMENSIONAL SPECIFICATIONS

CLARKLIFT® CS 30

3,000 pounds capacity, 24 inch load center

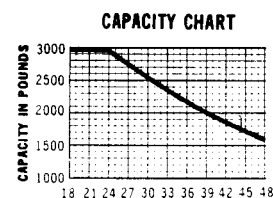
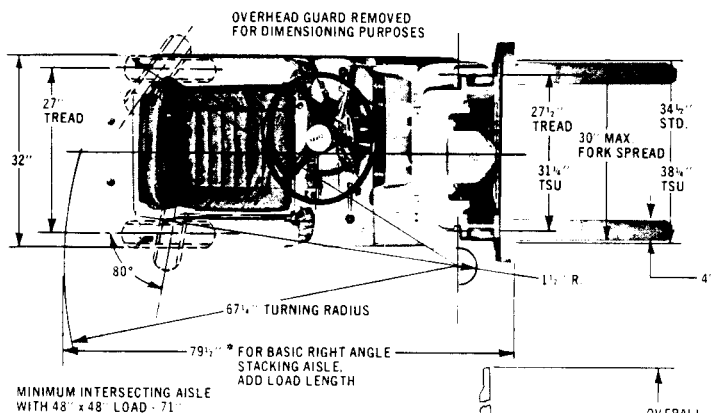

Load center in inches from front face of forks — Rated capacities shown above are computed with uprights in vertical position. Lifts above 144 maximum fork height contact factory. Specific capacities will be shown on truck nameplate.



Clark products and specifications are subject to improvements and changes without notice.

UPRIGHT DIMENSION TABLE

MFH		Overall Height Lowered	FREE LIFT	
STD. & HI-LO	FFL/TSU		STD.	HI-LO & FFL/TSU
70	—	53	16	—
76	—	56	16	—
82	—	59	16	—
88	—	62	16	—
94	135	65	16	45 1/2
100	144	68	16	48 1/2
*106	*153	71	16	51 1/2
112	162	74	16	54 1/2
118	*171	77	16	57 1/2
124	180	80	16	60 1/2
*130	*189	83	16	63 1/2
136	—	86	16	66 1/2
—	198	88	—	68 1/2
142	—	89	16	69 1/2
148	—	92	16	72 1/2
—	207	93	—	73 1/2
*154	—	95	16	75 1/2
—	216	98	—	78 1/2
160	—	99	16	79 1/2
166	—	102	16	82 1/2
—	225	103	—	83 1/2
172	—	106	16	86 1/2
*178	—	109	16	89 1/2

For overall height fully raised, add 49" to maximum fork height with LBRE; 20" without LBRE. * Indicates preferred standard sizes. Intermediate height available in increments of 3" MFH.

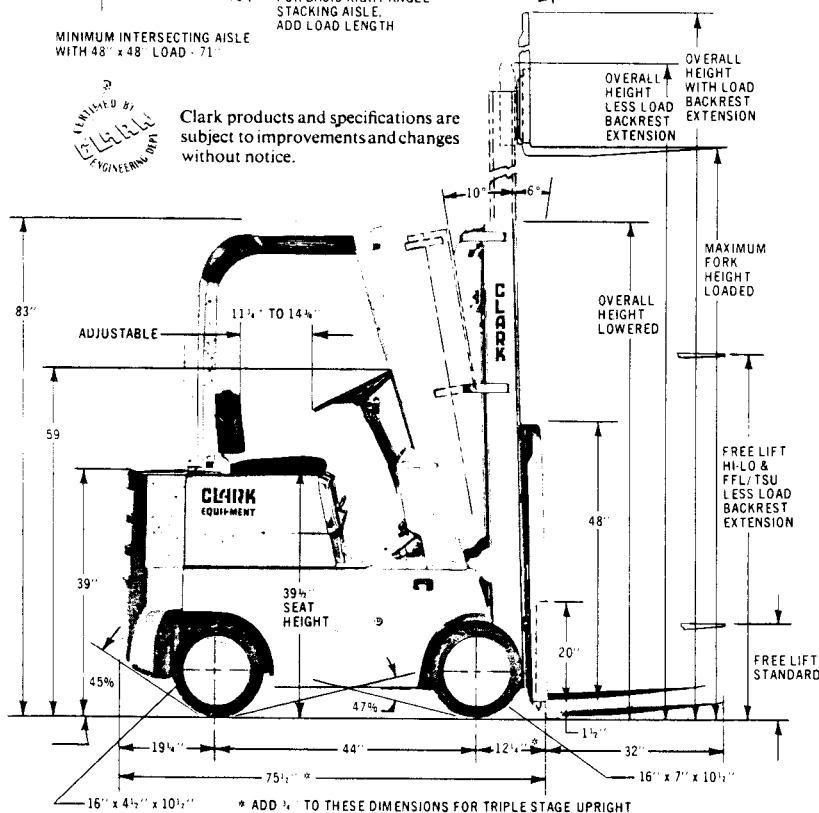

UNDERCLEARANCES

Upright	3"	Frame	4 1/2"
Drive Axle	3"	Counterweight	4"
Steer Axle	4"	Grade Clearance	45%



INDUSTRIAL TRUCK DIVISION



Specifications C20B, C20BP, C25B, CS30

AXLE END CAPACITY 1# each end

BATTERY 12 Volt Negative Ground

BRAKE PEDAL FREE TRAVEL

Left Foot Inching-Brake Pedal.....
..... 3/16 to 5/16 inch

Right Foot Brake Pedal.... 3/16 to 1/2 inch

COOLING SYSTEM

Capacity 10 quarts

DISTRIBUTOR

Rotation (viewed from cap end).....
..... Counterclockwise

Point Opening (inch) .022

Cam Angle Range.....(degrees) 31-34

Centrifugal Advance

	Dist. R.P.M.	Degrees
Start	300	.5-2.5

Intermediate 400 3-5

Intermediate 800 5.5-7.5

Maximum 1000 9-11

Contact Spring Tension.....(ounces) 19-23
(exert pull at 90° just behind contact)

ENGINE OIL CAPACITY

Crankcase (quarts) 3 1/2

Crankcase & Filter..... 4

FAN BELT DEFLECTION (long span)..... 3/4 inch

GENERATOR

Brush Spring Tension (ounces)..... 24-32

3rd. Brush Spring Tension..... 16-22

Field Current ... 1.69-1.79 amps. @ 12 volts

Cold Output
..... 25 amps. 14.0 volts @ 1970 (gen.) RPM

Charging Starts Cold
..... 25 amps. 750 (gen.) RPM

Charging Starts Hot
..... 25 amps. 2200 (gen.) RPM

HYDRAULIC PUMP CAPACITY

6 G.P.M. at 1450 engine R.P.M. - 100 P.S.I

HYDRAULIC PRESSURE RELIEF VALVE

By-Pass Pressure Setting 2000 P.S.I.

IGNITION TIMING 4° ATDC

Firing Order..... 1-3--2

SPARK PLUG GAP

Standard025

Resistor03

STARTING MOTOR

Brush Tension (oz.)..... 15

Lock Test

Draw current (amps.) 4-35

Volts 5.8

Torque (lb. ft.)..... 10.5

No Load Test

Draw Current 49 to 76

Volts 10.6

Speed (R.P.M.).... 6200 min. 9400 max.

STARTER RELAY

Point Opening020-.030

Opening Voltage..... (min.) 16

STEER AXLE

Axle Alignment:

Toe-in..... (inch) 1

Camber Angle (degrees) 1

Caster..... (degrees) 1

Left-hand Turning Radius Angle:

Left Wheel (degrees) 1

Right Wheel (degrees) 1

Right-hand Turning Radius Angle:

Right Wheel (degrees) 1

Left Wheel (degrees) 1

TRANSMISSION

Speeds 1 Forward 1 Reverse

Capacity 15 quarts



INDUSTRIAL TRUCK DIVISION



Specifications C20B, C20BP, C25B, CS30

(CONTINUED)

TIRE PRESSURE C20BP (drive tires)... 100 P.S.I.

VOLTAGE REGULATOR

Circuit Breaker

Armature Air Gap(inches) .020
Contact Point Gap020 ± 10%
Contacts Close 11.8 to 13.5 Volts
(125° F. ambient temp.)

Voltage Regulator

Armature Air Gap...(inches).075 ± 10%
Operating Voltages..... 13.5 to 14.4
(125° F. ambient temp.)

Current Regulator

Armature Air Gap...(inches) .075 ± 10%
Operating Amperage 31 to 35.5
(125° F. ambient temp.)

WHEEL MOUNTING TORQUE

Drive Wheels..... 125 lb. ft.

Steer Wheels..... 125 lb. ft.

PITMAN ARM LOCKNUT TORQUE100-125 lb. ft.

STEERING GEAR MOUNTING BOLTS AND CLAMP BOLT
TORQUE..... 90 lb. ft.



INDUSTRIAL TRUCK DIVISION



SPECIFICATIONS

L.P. Gas and Gasoline ENGINE TORQUE SPECIFICATIONS

Engines have many studs, bolts, and cap screws of special material and sizes and it is very important that care be exercised to torque all studs and bolts correctly.

The torque specifications, foot pounds, listed below MUST be followed in order to have the engine conform to the original specifications.

Size - Diameter	5/16"	3/8"	7/16"	1/2"	9/16"	5/8"
Cylinder Heads	-----	35-40	70-85	100-110	130-140	145-155
Manifolds	15-20	25-30	40-50	50-60	50-60	60-70
Gear Covers, Water Pumps, Front and Rear End Plates	15-20	25-30	50-55	80-90	-----	-----
Oil Pans	12-16	12-16	-----	-----	-----	-----



INDUSTRIAL TRUCK DIVISION



NEW MACHINE 50 HOUR SERVICE AND INSPECTION

Air Cleaner, Service	8H 403
Battery Test and Level Check	100H 603
Brake Master Cylinder Level Check	100H 303
Brake Pedal, Adjust	100H 302
Cooling System, Inspect	100H 103
Cylinder Head, Tighten	1000H 003
Engine Crankcase, Drain and Refill	100H 003
Engine Oil Filter, Change	100H 003
Fan Belt, Adjust	100H 203
Fuel Pump Strainer, Clean or Replace	500H 002
Hand Brake, Adjust	1000H 1103
Hydraulic Oil Filter, Change	500H 103
Intake and Exhaust Manifold, Tighten	500H 403
Lift Chains, Adjust	100H 403
Lubricate Machine.....	100H 702
Nuts, Bolts and Capscrews, Tighten	500H 403
Pressure Check Main Hydraulic System	1000H 1503
Steering Gear Level Check	100H 603
Transmission, Converter and Axle Adaptor Level Check	100H 002
Transmission, Converter and Axle Adaptor Change Filter	500H 003

N O T E

PERFORM THIS SERVICE AND INSPECTION AFTER
THE FIRST 50 HOURS OF OPERATION ON NEW
MACHINES.

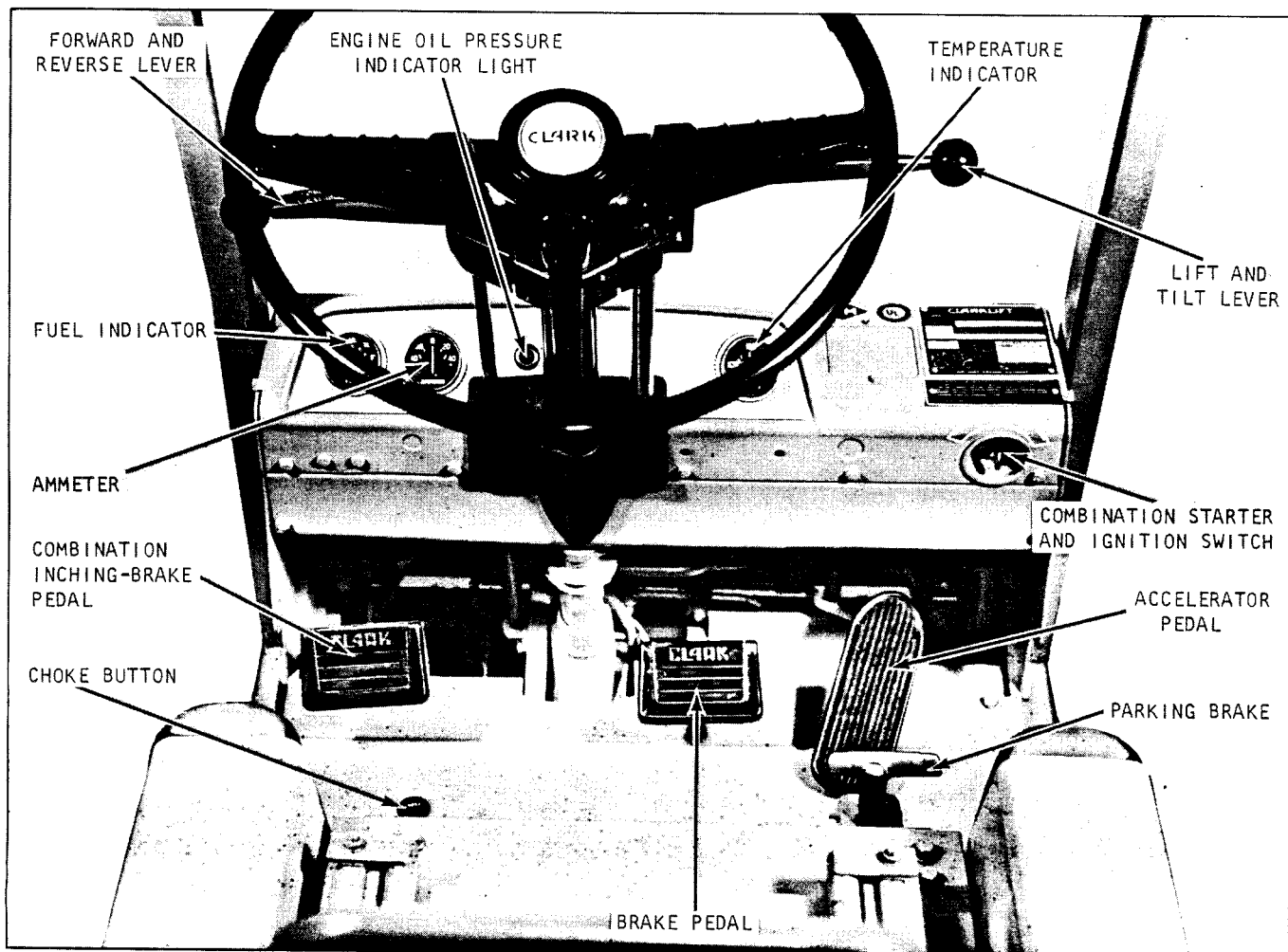

Plate 7761. Instruments and Controls

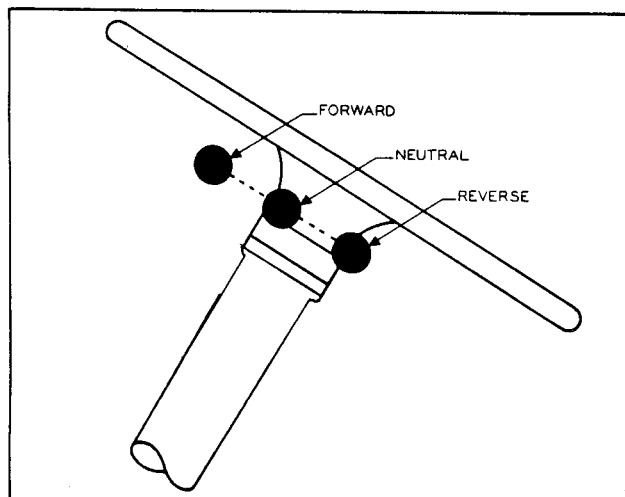

Plate 7759. Directional Control Lever

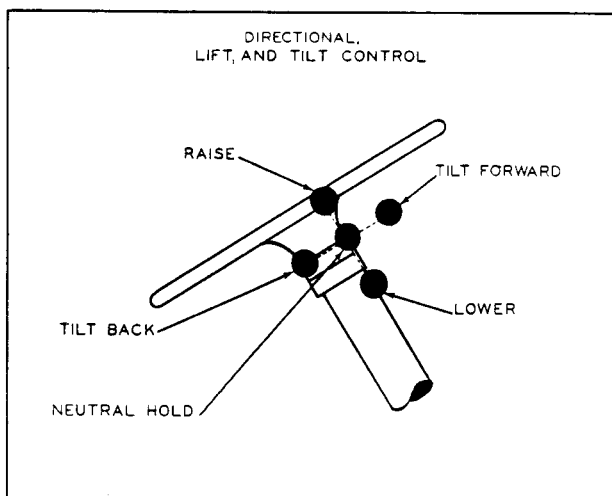

Plate 4448. Hydraulic Control Lever

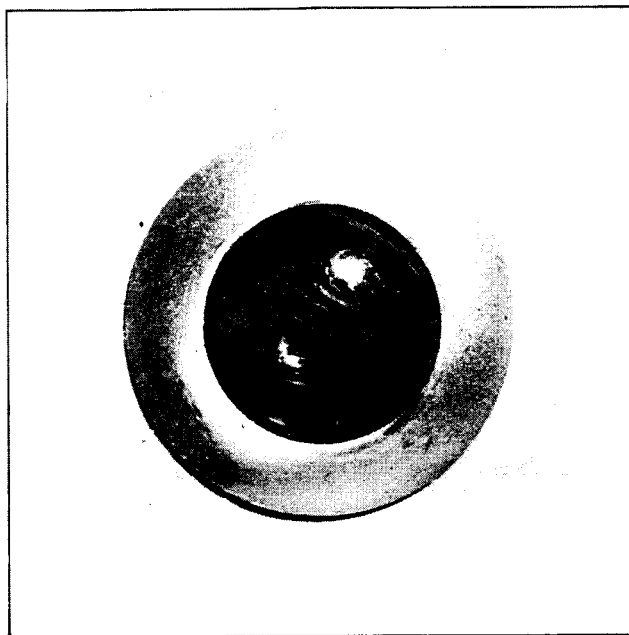

Plate 6885. Oil Pressure
Warning Light

C A U T I O N

IF OIL PRESSURE WARNING LIGHT COMES ON,
STOP THE ENGINE IMMEDIATELY AND FIND THE
CAUSE OF THE TROUBLE. REFER TO TROUBLE
SHOOTING SECTION FOR THIS INFORMATION.

C A U T I O N

ON NEW MACHINES, AFTER STARTING ENGINE --
RUN IT AT IDLE FOR 5 MINUTES, THEN STOP
ENGINE AND RECHECK OIL LEVEL IN CRANK-
CASE - BRING OIL LEVEL TO HIGH MARK, IF
NECESSARY.

C A U T I O N

DO NOT IDLE THE ENGINE FOR LONG PERIODS, AS IT
IS NOT ONLY DETRIMENTAL TO THE ENGINE BUT ALSO
INCREASES OPERATING COSTS AS YOU ARE USING FUEL
WITHOUT BENEFIT.

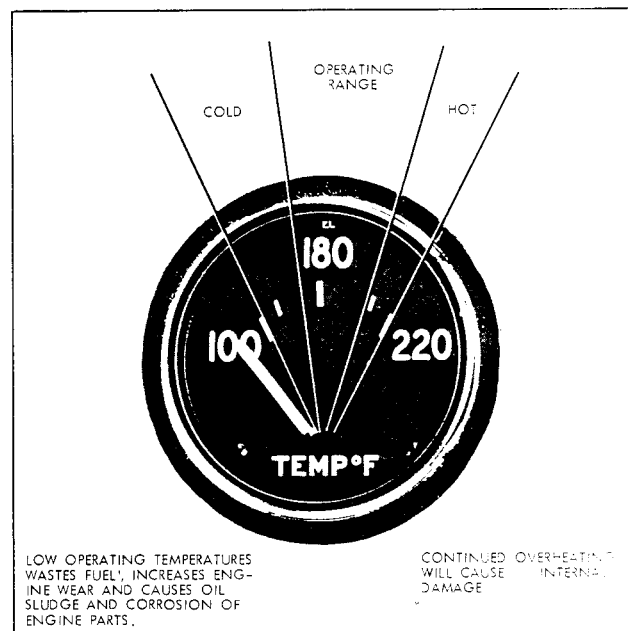

Plate 6287. Engine Coolant
Temperature Indicator

N O T E

BEFORE PLACING MACHINE IN OPERATION RUN
ENGINE A FEW MINUTES TO WARM OIL ESPE-
CIALLY IN COLD OPERATING CONDITIONS.

LOW OPERATING TEMPERATURES WASTES FUEL AND
INCREASES ENGINE WEAR.

N O T E

THE COOLANT TEMPERATURE SHOULD REGISTER 35°
TO 205° F. AFTER THE FIRST TEN OR FIFTEEN
MINUTES OF OPERATION.

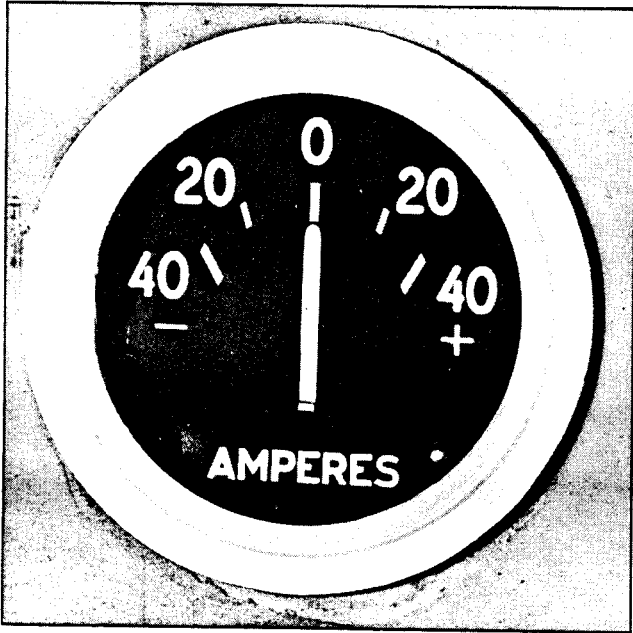

Plate 7647. Ammeter

AMMETER

The ammeter is connected in the generator (or alternator if used) and battery circuit in such a manner as to indicate rate of charge or discharge. If the generator (or alternator) is functioning properly the ammeter should show a small amount of charge at engine idle. As engine R.P.M. increases the rate of charge also increases. When the battery becomes fully charged the circuit is regulated to reduce the rate of charge and cause the ammeter needle to return to near neutral position, showing only a small amount of charge.

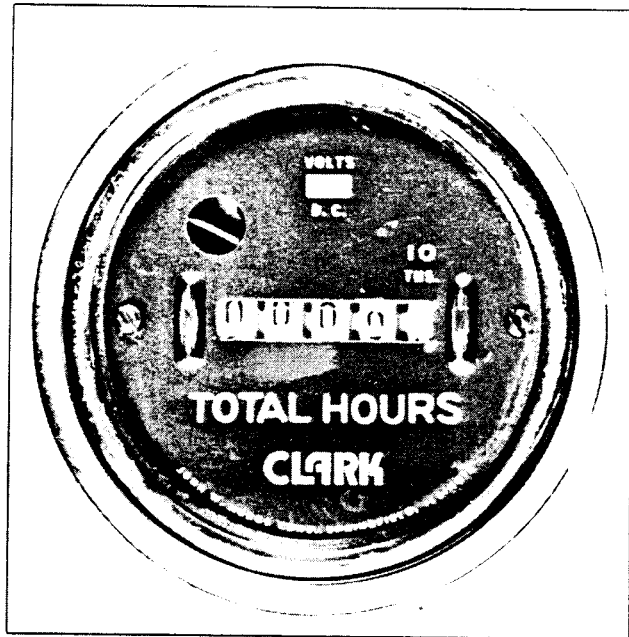

Plate 7162. Hour Meter

HOUR METER

The hour meter accurately records the actual hours of machine operation. This will serve as an aid in determining the time intervals for lubrication and preventative maintenance services.

N O T E

Refer to DIESEL ENGINE MANUAL for machines so equipped.

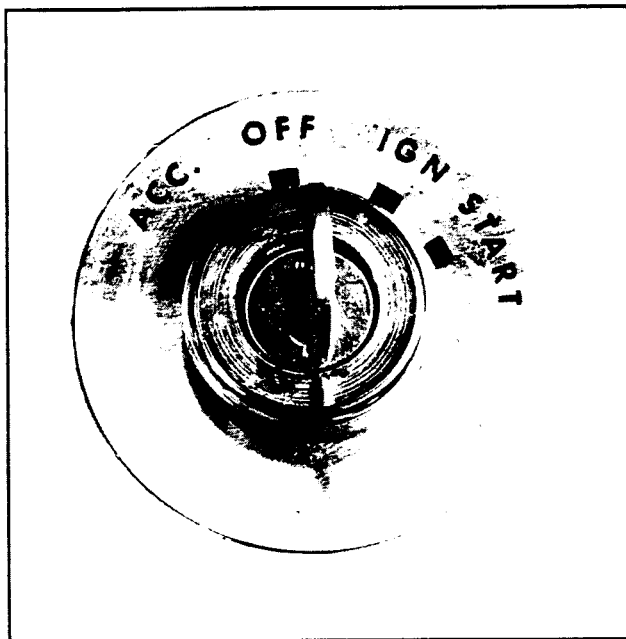

Plate 6418. Ignition Switch

STARTING

Place all transmission control levers in neutral position. Pull out on choke and engage the starter by actuating the ignition switch in the start position.

C A U T I O N

DO NOT ENGAGE THE STARTER LONGER THAN 15 SECONDS WITHOUT A MINUTE OR SO INTERVAL BETWEEN TRIALS.

If the engine becomes overchoked or flooded; push choke button in, depress accelerator pedal fully and engage starter. If all necessary equipment is in correct working order, the engine will start.

After engine has started, check instrument panel making certain the engine oil pressure indicator shows adequate pressure. If no oil pressure is indicated, stop engine and correct the difficulty.

N O T E

RUN ENGINE A FEW MINUTES TO WARM OIL BEFORE PUTTING MACHINE TO WORK, ESPECIALLY IN COLD OPERATING CONDITIONS.

TO OPERATE MACHINE

1. Place transmission control lever in neutral position and start engine.
2. Release parking brake and move transmission control lever into position for desired direction. Accelerate as required.
3. Inching Operation: To inch the machine into a load depress the left foot combination inching-brake pedal only far enough to permit gradual disengagement of power from the drive wheels. The master cylinder operated by the left foot pedal is so designed that after the inching mechanism has fully actuated, a further depression of the pedal will cause the brakes to become applied. The right foot pedal is not connected to the inching mechanism and has its separate master cylinder which serves to operate the brakes as on a conventional automobile. After the operator becomes familiar with the foot pedal controls and a definite feel is developed, inching may be accomplished in a smooth manner even when the engine is running at governed R.P.M. for fast lifting.

C A U T I O N

ALLOW FOOT TO REST ON INCHING BRAKE PEDAL ONLY WHEN INCHING IS DESIRED. DO NOT ALLOW FOOT TO REST ON INCHING PEDAL WHILE DRIVING MACHINE FROM POINT TO POINT. 'RIDING' THE INCHING PEDAL WILL CAUSE CONTINUED SLIPPAGE OF THE TRANSMISSION SELECTOR PACKS RESULTING IN OVERHEATING AND UNNECESSARY WEAR OR DAMAGE TO TRANSMISSION COMPONENTS.

TO STOP MACHINE

Remove foot from accelerator pedal and depress left inching pedal for enough to permit power to become disengaged from the drive wheels. Further depression of the left inching brake pedal will apply the brakes. Normally the left pedal is depressed in far enough to disengage power from the wheels while the right pedal is used for braking action. If machine is to be parked, place transmission controls in neutral, apply hand brake and shut engine off.

C A U T I O N

IF THE ENGINE HAS BEEN OPERATING AT OR NEAR FULL LOAD, IT SHOULD BE ALLOWED TO RUN AT FAST IDLE (600 to 800 R.P.M.) FOR ONE OR TWO MINUTES AFTER LOAD IS REMOVED BEFORE BEING STOPPED. THIS ALLOWS INTERNAL ENGINE TEMPERATURES TO EQUALIZE.

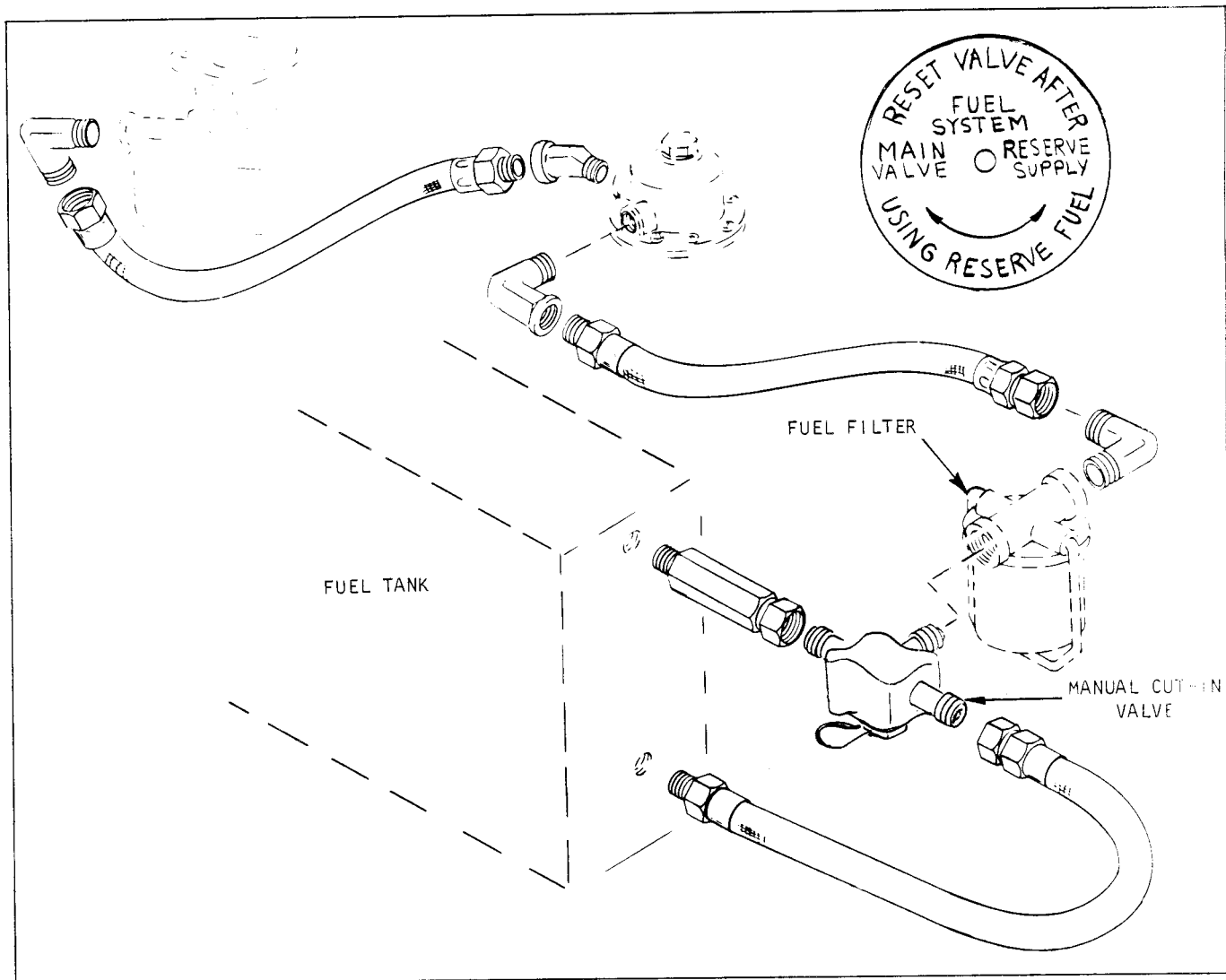

Plate 7806. Fuel Reserve Valve

The auxiliary fuel reserve manual cut-in valve located at the rear of the fuel tank, may be turned to the reserve supply position in the event the main fuel tank supply becomes exhausted. The reserve fuel supply of approximately 1/2 gallon will in

most cases be adequate to allow the machine to be driven to its refueling location. After the fuel supply has been replenished the manual cut-in lever should be turned to the main tank position.



INDUSTRIAL TRUCK DIVISION



OPERATIONS

To Move A Load.

The forks should be adjusted sidewise on the fork bars to obtain firm support and maximum balance of the load. Raise or lower the forks to the proper level and engage the load by driving forward. Tilt the upright backward sufficiently to adequately cradle the load, and raise load sufficiently to clear obstructions, accelerating engine slightly at the same time. Back away from stack.

The operator should have clear vision ahead when moving in a forward direction. When this is not possible, the operator should drive in reverse and turn in his seat to obtain clear vision backward.

When the load is to be deposited, enter the area squarely, especially when placing one load on top of another, in order that all piles will be square and secure. Place load directly over desired area and slowly lower into position. Disengage forks from the load by using necessary lift-tilt and then back away.

Loads will vary in size, shape, method of packaging, stacking procedures, etc. The best way to handle a load will depend on these factors. If in doubt, consult with your supervisor.

I M P O R T A N T

EVERY 8 OPERATING HOURS (OR EVERY SHIFT) ELEVATE UPRIGHT TO THE UPPER LIMIT. THIS WILL PROVIDE LUBRICATION TO THE TOP PORTION OF THE LIFT CYLINDER. CHECK FOR NORMAL SEQUENCE OF OPERATION.

OPERATING SAFETY RULES AND PRACTICES.

1. Operators of powered industrial trucks should be physically qualified. An examination should be made on an annual basis and include such things as field of vision, hearing, depth perception and reaction timing.

2. Only trained and authorized operators should be permitted to operate a powered industrial truck. Methods should be devised to train operators in the safe operation of powered industrial trucks. It is recommended that badges or other visual indication of the operator's authorization should be displayed at all times during work period.

GENERAL.

1. Safeguard the pedestrians at all times. Do not drive a truck up to anyone standing in front of a bench or other fixed object.

2. Do not allow anyone to stand or pass under the elevated portion of any truck, whether loaded or empty.

3. Unauthorized personnel should not be permitted to ride on powered industrial trucks. A safe place to ride should be provided where riding of trucks is authorized.

4. Do not put arms or legs between the uprights of the mast or outside the running lines of the truck.

5. When leaving a powered industrial truck unattended, load engaging means should be fully lowered, controls should be neutralized, power shut off, brakes set, key or connector plug removed. Block wheels if truck is parked on an incline.

6. Maintain a safe distance from the edge of ramps or platforms and do not, while on any elevated dock or platform, push freight cars. Do not use trucks for opening or closing freight doors.

7. Have brakes set and wheel blocks in place to prevent movement of trucks, trailers, or railroad cars while loading or unloading. Fixed jacks may be necessary to support a semi-trailer during loading or unloading when the trailer is not coupled to a tractor. Check the flooring of trucks, trailers, and railroad cars for breaks and weakness before driving onto them.

8. Be sure of sufficient headroom under overhead installations, lights, pipes, sprinkler system, etc.

9. Use an Overhead Guard and Load Backrest Extension unless conditions prevent their use.

```

x x x x x x x x x x x x x x x x x x x x x x x x x x x x
x
x                               W A R N I N G
x
x AN OVERHEAD GUARD IS INTENDED TO OFFER
x
x PROTECTION FROM THE IMPACT OF SMALL
x
x PACKAGES, BOXES, BAGGED MATERIAL, ETC.,
x
x REPRESENTATIVE OF THE JOB APPLICATION,
x
x BUT NOT TO WITHSTAND THE IMPACT OF A
x
x FALLING CAPACITY LOAD.
x
x x x x x x x x x x x x x x x x x x x x x x x x x x x x

```

10. Use only approved industrial trucks in hazardous locations.



INDUSTRIAL TRUCK DIVISION



OPERATIONS

11. Elevate personnel only on an approved safety platform firmly secured to the lifting carriage and/or forks.
12. Report all accidents involving personnel, building structures, and equipment.
13. Fire aisles, access to stairways, and fire equipment should be kept clear.

TRAVELING.

1. Observe all traffic regulations including authorized plant speed limits. Under normal traffic conditions, keep to the right. Maintain a safe distance, approximately three truck lengths from the truck ahead, and keep the truck under control at all times. Use of truck on public roads should conform to local traffic regulations.
2. Yield the right of way to ambulances, fire trucks, or other vehicles in emergency situations.
3. Do not pass another truck traveling in the same direction at intersections, blind spots, or at other dangerous locations.
4. Slow down and sound horn at cross aisles and other locations where vision is obstructed. If the load being carried obstructs forward view travel with the load trailing.
5. Cross railroad tracks diagonally wherever possible. Do not park closer than 8 feet from center of railroad tracks.
6. Look in the direction of, and keep a clear view of the path of travel.
7. Ascend or descend grades slowly.

When ascending or descending grades in excess of 10%, loaded trucks should be driven with the load upgrade.

Unloaded trucks should be operated on all grades with the load engaging means downgrade.

On all grades the load and load engaging means should be tilted back if applicable, and raised only as far as necessary to clear the road surface.

8. Under all travel conditions the truck should be operated at a speed that will permit it to be brought to a stop in a safe manner.

9. Travel with load engaging means or load low and, where possible, tilted back. Do not elevate the load except during stacking.

10. Make starts, stops, turns or direction reversals in a smooth manner so as not to shift load and/or overturn the truck.

11. Stunt driving and horseplay should not be permitted.

12. Slow down for wet and slippery floors.

13. Before driving over a dockboard or bridgeplate, be sure that it is properly secured. Drive carefully and slowly across the dockboard or bridgeplate and never exceed its rated capacity.

14. Do not run vehicles onto any elevator unless specifically authorized to do so. Approach elevators slowly, and then enter squarely after the elevator car is properly leveled. Once on the elevator, neutralize the controls, shut off power, and set brakes. It is advisable that all personnel leave the elevator before a truck is allowed to enter or leave.

15. Avoid running over loose objects on the roadway surface.

LOADING.

1. Handle only stable or safely arranged loads. When handling off-center loads which cannot be centered, operate with caution.

2. Handle only loads within the rated capacity of the truck.

3. Adjust for long or high (including multiple tiered) loads which may affect capacity.

4. When attachments are used, particular care should be taken in securing, manipulating, positioning, and transporting the load. Operate trucks equipped with attachments as partially loaded trucks when not handling a load.

5. Place load engaging means under the load as far as possible and carefully tilt the mast backward to stabilize the load. Caution should be used in tilting backward with high or segmented loads.

6. Use extreme care when tilting load forward or backward particularly when high tiering. Do not tilt forward with load engaging means elevated except to pick up a load. Do not tilt an elevated load forward except when the load is in a deposit position over a rack or stack. When stacking or tiering use only enough backward tilt to stabilize the load.

OPERATOR CARE OF THE TRUCK.

1. Give special consideration to the proper functioning of tires, horn, lights, battery, controller, lift system (including load engaging means, chains, cable, and limit switches), brakes and steering mechanism. If at any time



INDUSTRIAL TRUCK DIVISION



OPERATIONS

OPERATOR CARE OF THE TRUCK (CONT.).

a powered industrial truck is found to be in need of repair, defective, or in any way unsafe, the matter should be reported immediately to the designated authority, and the truck should be taken out of service until it has been restored to safe operating condition.

2. Do not make repairs or adjustments unless specifically authorized to do so.
3. Do not fill fuel tanks while engine is running and avoid spillage.
4. Spillage of oil or fuel should be carefully washed away or completely evaporated and fuel tank cap replaced before restarting engine.
5. Do not operate a truck with a leak in the fuel system until the leak has been corrected.
6. Do not use open flames for checking electrolyte level in storage batteries or gasoline level in fuel tanks.

NOTE

The preceding is reproduced from:

American National Standard ... Safety Standard
for Powered Industrial Trucks. B56.1 - 1969

SERVICE RECORDER:

The service recorder records number of productive lifts in addition to busy and idle time of each truck. The records are made on a 6-inch diameter chart, revolving once. This model records the raising or lowering of a predetermined load. The limits generally are between 5% of the truck's capacity and a full load. Minimums may be established, and the chart will show only those lifts of the minimum weight or greater. Selective load records are made by using an adjustable pressure switch. This switch fits into the hydraulic system between the lift control and the cylinder. It is sensitive to system pressure changes but insensitive to surges or vibration. Switch setting can be adjusted externally and then sealed. The load recording stylus is always in contact with the chart. When the predetermined load or more is lifted, an electrical circuit is closed and this stylus is lifted up, making a record. A surge dampener is recommended particularly when lift trucks are in service where rough or uneven floors occur.

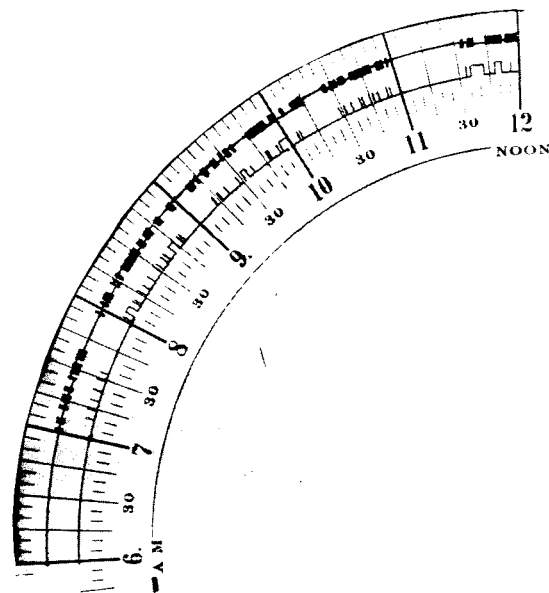

Plate 10161. Service Recorder Chart

HOW TO OPERATE SERVICE RECORDERS

Wind the Clock Movement: No key is needed. Turn the star-shaped winding disc clockwise until the movement is wound fairly tight. Do not overwind. It is a good practice to wind the clock each time a chart is changed even if it is not run down.



Plate 10164

Place Chart in the Recorder: Snap up the two finger-like clamps. Slip the chart down over the now vertical clamps to the face of the winding disc.



Plate 10165

To Set the Chart: Before clamping it down, turn the chart so that the place on it that corresponds to the present time of the day is at the little white spot on rim of Recorder case. If this is not done correctly, the recorder will be "that much off" all day.

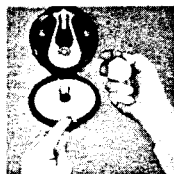

Plate 10166

Fasten the Chart in Place By snapping down the two clamping fingers. Now close and lock the Recorder and it is ready to operate for its full cycle, the length of time depending on the model and clock speed.



Plate 10167

HOW TO READ THE CHART:

This section of chart shows a typical record. The wide marks in the outer record band show when the truck was in motion. The fine line shows down time.

Inner record band shows lifts. Load recording stylus normally rests at lower or inner position. When activated by pressure switch, it is moved outward to record each lift.

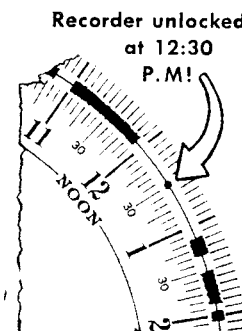

Plate 10162. Service Recorder Chart

When the key is turned to lock or unlock the Recorder, the stylus makes a round dot at the exact time of locking or unlocking. The mark appears on the face of the chart, and it is also embossed on the back. It is unmistakable.



INDUSTRIAL TRUCK DIVISION



OPERATIONS

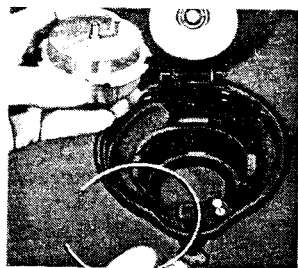

Plate 10163. Clock Exchange

HOW TO EXCHANGE CLOCK MOVEMENTS:

A clock movement is inherently a delicate mechanism that should receive reasonably good care. We have tried to make the clocks in Servis Recorders as rugged as possible to withstand the rough use they sometimes get. If the clock should fail, it can be easily lifted out and mailed in for repair or replacement. Merely unscrew the winding disc by turning it counter-clockwise and pry out wire retaining ring.

To replace the clock movement, first notice that one of the four retaining lugs in the Recorder case is wider than the rest. Match this wide space in movement top and settle movement into place. Then force wire retaining ring into place securely under lugs.

It is a good policy to have a spare clock movement in stock to insure uninterrupted service. Extra clocks are inexpensive.



INDUSTRIAL TRUCK DIVISION



FUEL HANDLING AND STORAGE SAFETY

Liquefied Petroleum Gas Fuel (LPG Powered Trucks)

1. The storage and handling of liquefied petroleum gas (LP-Gas) should be in accordance with the Standard for Storage and Handling of Liquefied Petroleum Gases (NFPA No. 58, USA Standard Z106.1-1965).
2. Trucks using LP-Gas should be refueled only at locations designated for that purpose. Safe outdoor locations are preferable to indoor. Trucks should be refueled as provided in the Standard for the Storage and Handling of Liquefied Petroleum Gases (NFPA No. 58, USA Standard Z106.1-1965.)
3. Reasonable care should be exercised in handling of LP-Gas containers to avoid damage. Do not drop, throw, roll, or drag LP-Gas containers or any associated parts of the containers or fuel systems.
4. Do not over-fill LP-Gas containers.
5. Engine should be stopped and operator off the truck during refueling.
6. Trained and designated personnel should recharge or exchange LP-Gas containers.
7. Personnel engaged in recharging of LP-Gas containers should wear protective clothing such as face shield, long sleeves, and gauntlet gloves.
8. Never use a match or flame to check for leaks, use a soap solution.
9. LP-Gas powered trucks should not be refueled nor stored near underground entrances, elevator shafts nor any other place where LP-Gas could collect in a pocket causing a potentially dangerous condition.
10. Trucks equipped with permanently mounted LP-Gas containers should be refueled outdoors.
11. Exchange of removable LP-Gas containers preferably should be done outdoors, but may be done indoors. Means should be provided in the fuel system to minimize the escape of fuel when the containers are exchanged. This should be accomplished by either of the following methods:
 - A. Using an automatic quick closing coupling (a type closing in both directions when uncoupled) in the fuel line, or.....
 - B. Closing the valve at the LP-Gas container and allowing the engine to run until the fuel in the line is consumed.
12. When installing removable LP-Gas containers they should be so located on the truck that the safety pressure relief valve opening is always in contact with the vapor space (top) of the cylinder. This is accomplished by an indexing pin which, when the tank is properly installed, positions the container.
13. All reserve LP-Gas containers should be stored and transported with the service valve closed. Safety relief valves should have direct communication with the vapor space of the container at all times.
14. The careless handling of LP-Gas containers can result in a serious accident. Extreme care should be exercised when transporting containers so that they are not accidentally dropped or physically damaged. When it is necessary to move more than one container at one time, a proper carrying device should be provided.
15. Physical damage such as dents, scrapes, or gouges, may materially weaken the structure of the LP-Gas container and render it unsafe for use. All LP-Gas containers should be examined before recharging and again before reuse, for the following defects or damage:
 - A. Dents, scrapes, and gouges of the pressure vessel.
 - B. Damage to the various valves and liquid level gage.
 - C. Debris in the relief valve.
 - D. Indications of leakage at valves or threaded connections.
 - E. Deterioration damage or loss of flexible seals in the fill or servicing connections.All defective or damaged LP-Gas containers should be removed from service.
16. Smoking should be prohibited in the refueling area.
17. Whenever vehicles using LP-Gas as a fuel are parked overnight or stored for prolonged periods of time indoors, with the fuel containers in place, the service valve on the fuel container should be closed.



INDUSTRIAL TRUCK DIVISION



LUBRICATION AND PREVENTIVE MAINTENANCE

When checking or adjusting L.P. Gas equipment be sure to:

1. Properly ventilate work area.
2. Eliminate ignition sources (sparks, pilot lights etc.).
3. Prohibit smoking.
4. Have fire fighting equipment present.
5. Check all equipment, lines, connections with soapy water. NEVER USE A MATCH OR FLAME WHEN CHECKING FOR LEAKS.

6. Check cylinder (container) for security of mounting.

7. Inspect hoses, grommets or whatever means is used to protect hoses from damage where they run through sheet metal etc. Replace any component that is unfit for further service.

8. Check all equipment for security of mounting.

9. Check the Solenoid Lock-Off Valve to be sure it is working. Upon turning off the ignition switch there should be an audible click indicating the valve has actuated shutting off the fuel flow at the valve. The valve should not open again until the ignition switch is turned on and the engine cranked. Cranking the engine provides oil pressure to the engine oil pressure sending unit which actuates completing an electrical circuit to the solenoid lock-off valve. The valve then opens allowing the L.P. Gas to pass through.

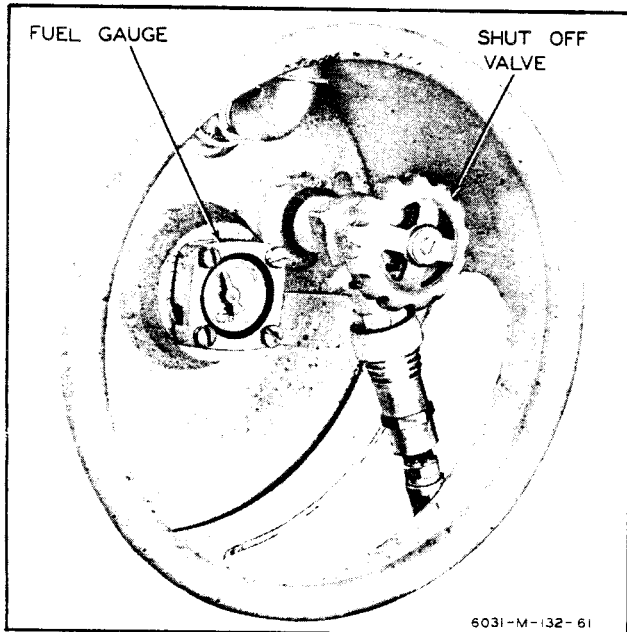

Plate 6031. Typical L.P. Gas Container

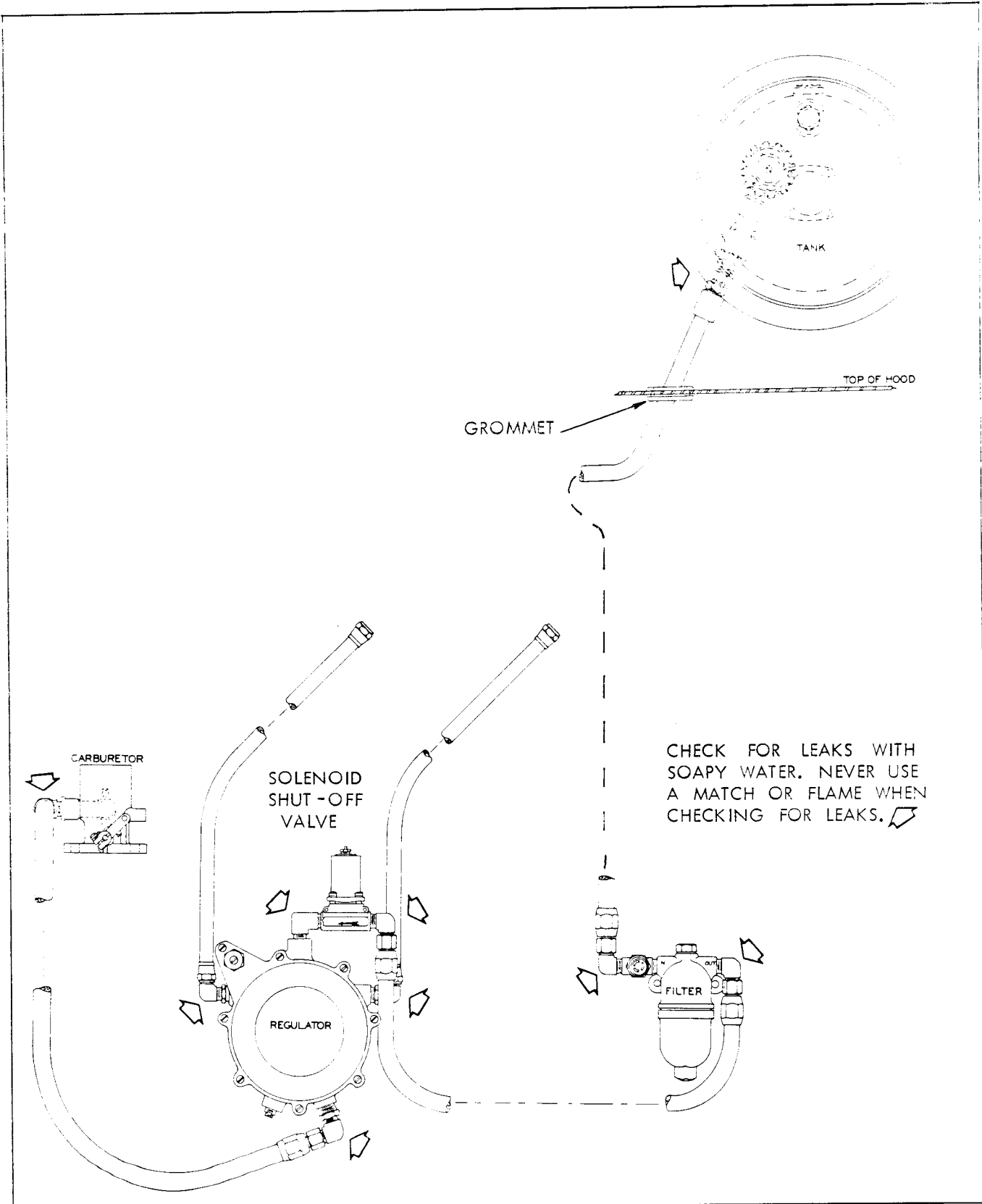

Plate 7405. Typical L.P. GAS Installation



INDUSTRIAL TRUCK DIVISION



LUBRICATION AND PREVENTIVE MAINTENANCE

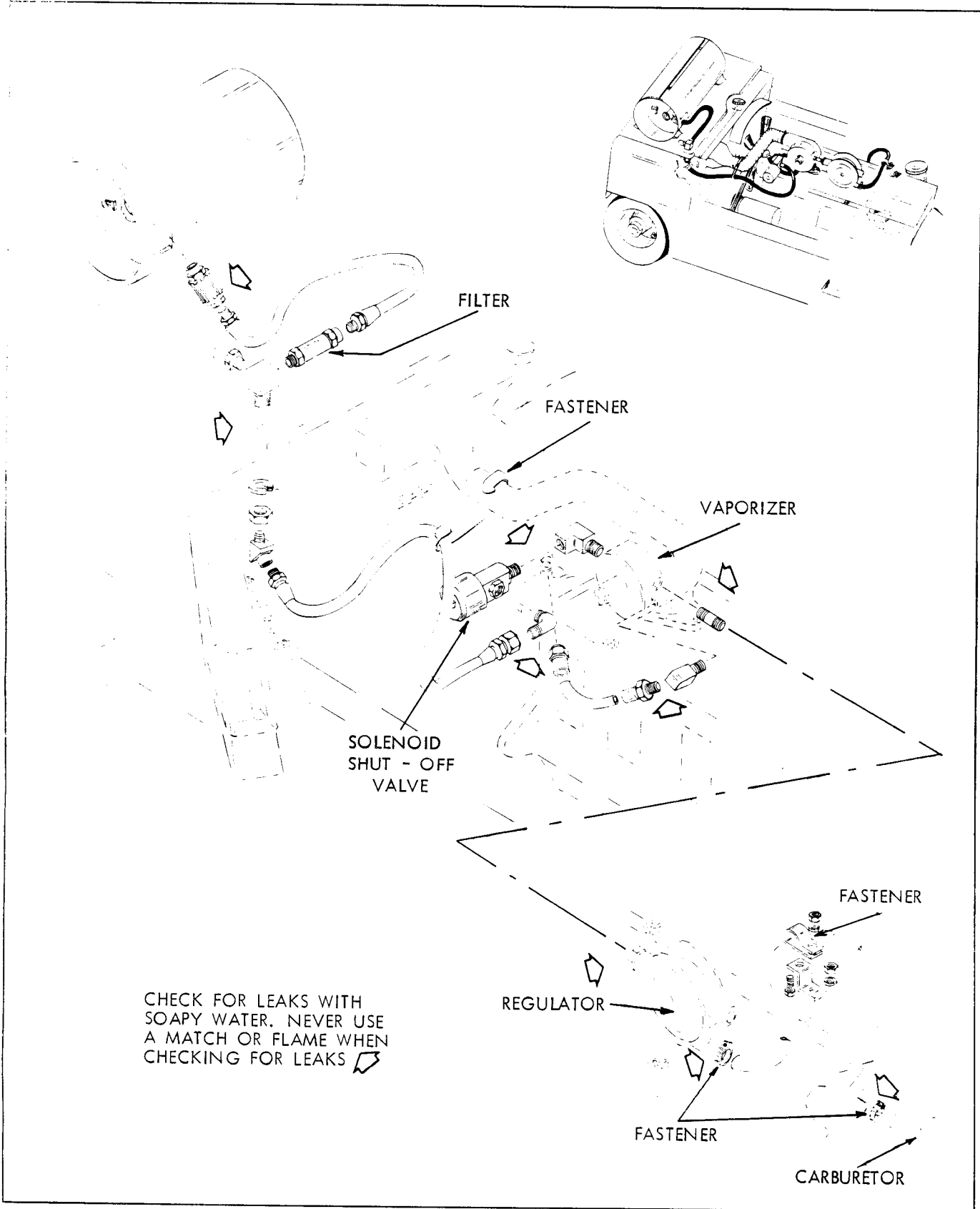

Plate 7406. Typical L.P. GAS Installation



INDUSTRIAL TRUCK DIVISION



FUEL HANDLING AND STORAGE SAFETY

(Gasoline Powered Trucks)

Liquid Fuels. (Such as Gasoline and Diesel Fuel).

1. The storage and handling of liquid fuels should be in accordance with the Flammable and Combustible Liquids Code. (NFPA No. 30).

2. Trucks using liquid fuels should be refueled only at locations designated for that purpose. Safe outdoor locations are preferable to those indoors. The Flammable and Combustible Liquids Code (NFPA No. 30), Paragraph 7211, outlines recommendations for arranging safe indoor fueling facilities.

3. Engines should be stopped and operator off the truck during refueling.

4. Liquid fuels not handled in approved dispensing pumps should be transported in safety cans. Safety cans should be inspected regularly for damage to closures and for leaks; faulty cans repaired or replaced. Care should be exercised in handling of safety cans to avoid damage.

5. Reasonable care should be exercised to prevent the spillage of fuel or overfilling either the vehicle fuel tanks or safety cans. Filler cap should be replaced and any spilled fuel disposed of by using a noncombustible adsorbent before the engine is restarted.

6. Smoking should be prohibited in the refueling area.



INDUSTRIAL TRUCK DIVISION



LUBRICATION AND PREVENTIVE MAINTENANCE INDEX

	Time Interval & (H=Hours)	Page Number (0000-)		Time Interval & (H=Hours)	Page Number (0000-)
<u>(8 HOURS)</u>			<u>(100 HOURS cont'd)</u>		
Air Cleaner Service	8H	403	Steer Gear level check	100H	603
Brake Pedal Operation	8H	303	Transmission & Converter level check	100H	001
Brake Operation, Parking	8H	303	<u>(500 HOURS)</u>		
Crankcase Oil Level check....	8H	003	Fuel Pump	500H	00
Engine Cooling System check..	8H	103	Fuel Pump Strainer	500H	00
Engine Coolant Temp. Ind. ...	8H	203	Hyd. Oil Filter change	500H	00
Fuel Tank check	8H	001	Hyd. Sump Tank drain & refill	500H	405
Horn.....	8H	001	Nuts, Bolts and Capscrews, tighten	500H	403
Horn Fuse	8H	001	Steering Axle and Linkage adjustment	500H	302
Hydraulic Control Levers.....	8H	503	Steering Gear adjustment....	500H	202
Hyd. Sump Tank Level check...	8H	503	Transmission and Converter Oil Filter	500H	003
Ignition Fuse	8H	001	Transmission, Converter & Axle Adaptor drain and refill	500H	000
Oil Pressure Indicator	8H	203	<u>(1000 HOURS)</u>		
Tires Inspect	8H	602	Axle Ends clean and repack..	1000H	805
<u>(100 HOURS)</u>			Brake Adjusters	1000H	1002
Battery level and test	100H	603	Brake System; test, adjust and bleed	1000H	912
Brake Master Cylinder level check	100H	303	Carburetor, adjust	1000H	403
Brake Pedal, adjust	100H	302	Compression test, Engine....	1000H	10
Cooling System	100H	103	Cooling System, inspect and clean.....	1000H	1200
Engine Breather	100H	003	Crankcase Ventilation	1000H	00
Engine Crankcase	100H	003	Cylinder Head Tightening Sequence	1000H	003
Engine Oil Filter	100H	003	Distributor, inspect and adjust	1000H	203
Fan Belt, adjust	100H	203	Engine Tune-Up	1000H	001
Fuel Tank and Lines	100H	001	Generator, inspect	1000H	703
Hyd. Sump Tank Breather.....	100H	503	Governor, adjust	1000H	503
Hyd. System inspect	100H	403			
Lift Brackets, inspect	100H	403			
Lift Chain, adjust	100H	403			
Lubrication Charts.....	100H	702			



INDUSTRIAL TRUCK DIVISION



LUBRICATION AND PREVENTIVE MAINTENANCE INDEX

(1000 HOURS cont'd)	Time Interval & Number (H=Hours)	Page Number (0000-)	LUBRICATION & PREVENTIVE MAINTENANCE ILLUSTRATIONS		
			Description	Time Interval & Number (H=Hours)	Page Number (0000-)
Hand Brake, adjust	1000H	1103			
Intake and Exhaust Valve Clearance, adjust	1000H	003	Lube. & Prev. Main. illus.	8H	000
Ignition Timing	1000H	304	Lube. & Prev. Main. illus.	100H	000
Neutral Starting Switch adjustment	1000H	1793	Lube. Instruction Diagram	100H	702
Pressure checks (Main Hydraulic System)	1000H	1503	Lube. & Prev. Main. illus.	500H	000
Transmission Pressure checks..	1000H	1703	Lube. & Prev. Main. illus.	1000H	000
Spark Plugs, clean & adjust...	1000H	103			
Starter, inspect.....	1000H	603			
Steer Wheel Bearings, inspect & adjust	1000H	803			
Upright & Lift Carriage Roller Adjustments checks	34M001A				
Regulator, inspect	1000H	704			
Wiring, inspect	1000H	704			

NOTE

When performing the 100, 500 or 1000 Hour Lubrication and Preventive Maintenance, always include the previous Lubrication and Preventive Maintenance Schedules.

8 HOURS

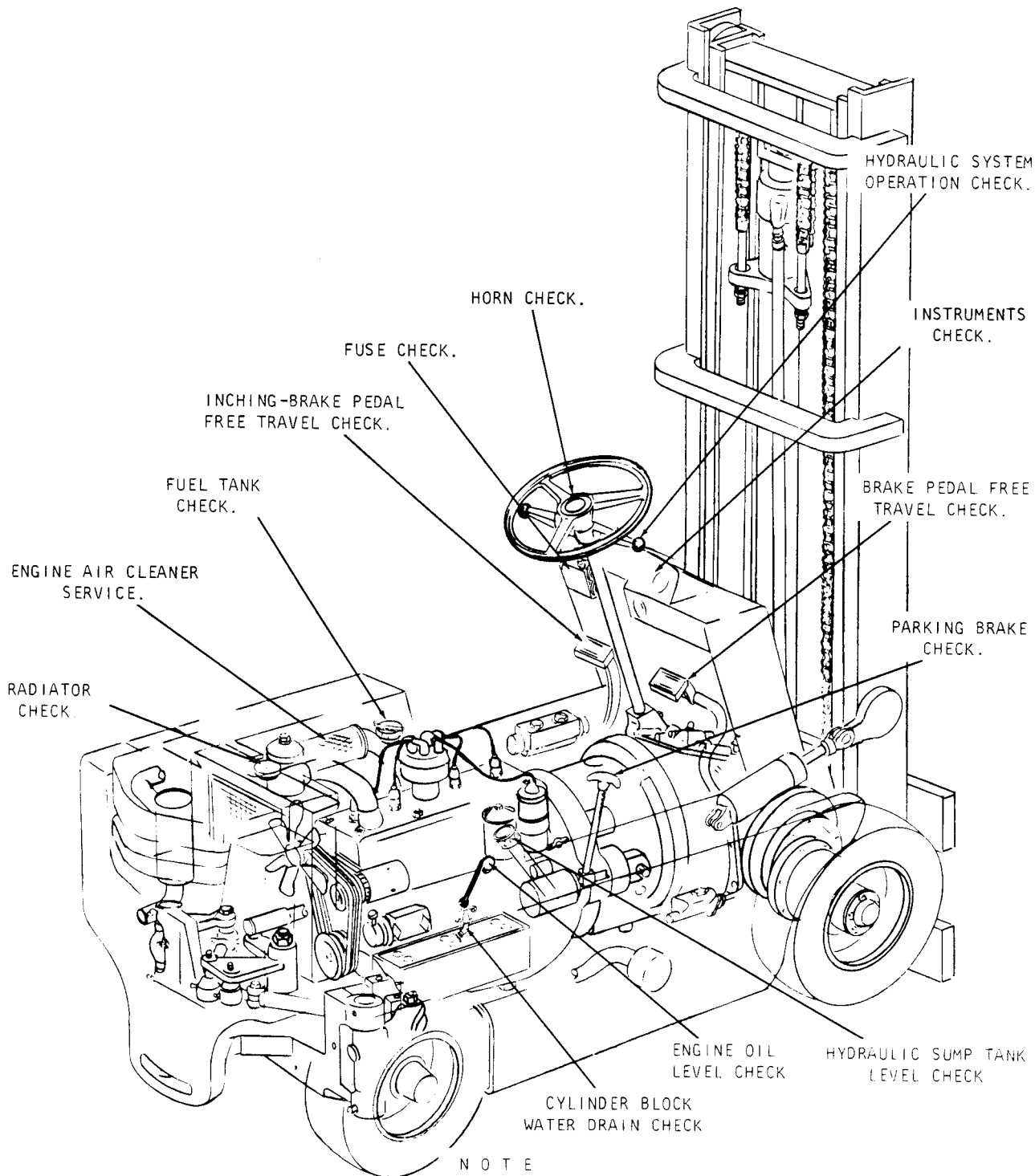

AFTER EACH 8 HOURS OF OPERATION, PERFORM THE ABOVE PREVENTIVE MAINTENANCE SERVICES.

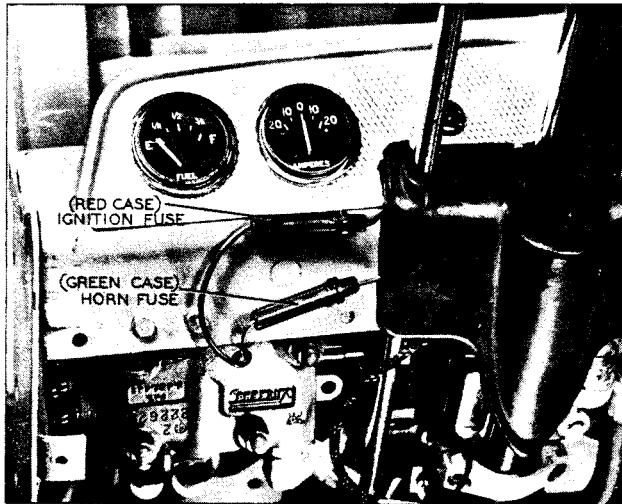

Plate 6624. Horn and Ignition Fuse

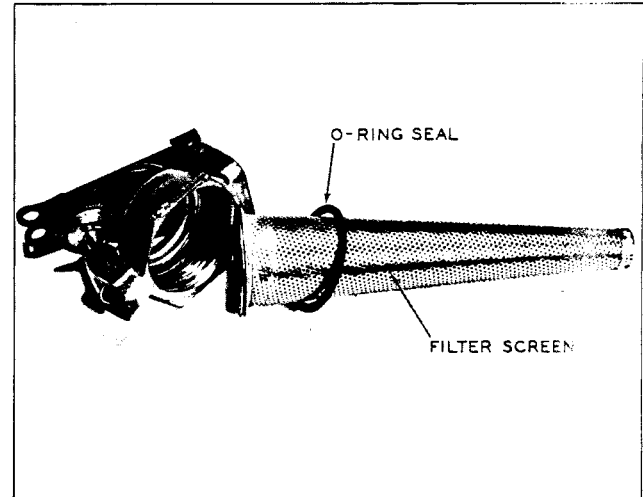

Plate 6627. Fuel Tank Filler Cap and Screen

HORN

Check to be sure the horn is working properly.

FUSES

Check the electrical circuit fuses. The fuse holders are located beneath the dash. A red wire leads to the ignition fuse holder and a green wire leads to the horn fuse holder.

FUEL TANK

Check fuel supply and fill if necessary. Use a good grade of fuel.

Before filling full tank, make certain the filler cap screen is in place and not damaged (on machines so equipped).

WARNING

DO NOT FILL THE TANK WITH THE FILLER CAP SCREEN REMOVED.



INDUSTRIAL TRUCK DIVISION



LUBRICATION AND PREVENTIVE MAINTENANCE

ENGINE CRANKCASE

Before attempting to start the engine, first make sure that it has sufficient oil. The oil filler pipe is located on the left side of the machine. The oil level stick is of the dipstick or bayonet type and is located on the right side of the machine. Fill the crankcase reservoir through the filler pipe to the proper level as indicated on the dipstick.

CAUTION

NEVER PERMIT THE OIL LEVEL TO FALL BELOW THE "ADD" MARK ON THE DIPSTICK.

DO NOT OVERFILL THE CRANKCASE, AS TOO MUCH OIL WILL BRING THE LEVEL HIGH ENOUGH FOR THE CONNECTING RODS TO DIP, THUS CAUSING EXCESSIVE QUANTITIES OF OIL TO BE THROWN TO THE CYLINDER WALLS RESULTING IN OIL CONSUMPTION, SMOKING, EXCESSIVE CARBON DEPOSITS AND FOULED SPARK PLUGS.

NOTE

ON L.P. GAS MACHINES, USE A NON-DETERGENT OIL DURING BREAK-IN PERIODS.

Crankcase Capacity — Refer to Specifications

	Service "MS" Oils	
S.A.E. 10W	0 ^o to 32 ^o F.	
S.A.E. 20W	32 ^o to 75 ^o F.	
S.A.E. 30	above 75 ^o F.	

or use 10W — 30 MULTI-GRADE OIL

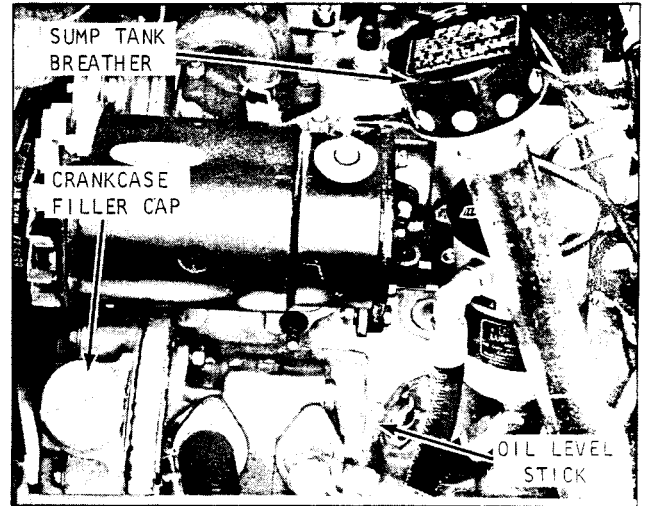

Plate 7758. Engine Crankcase Fill

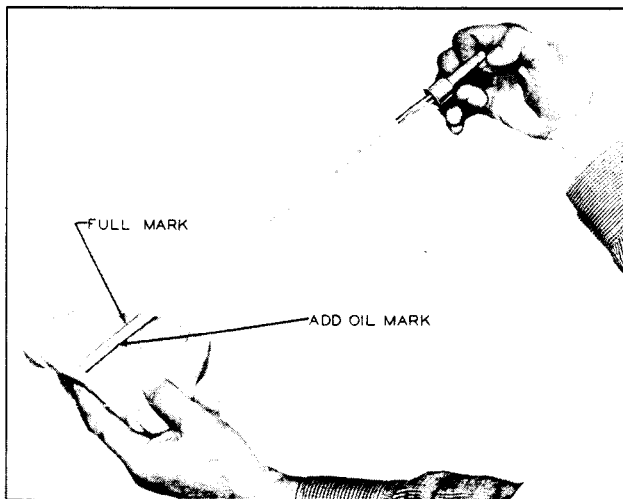

Plate 3145. Crankcase Oil Check



INDUSTRIAL TRUCK DIVISION



LUBRICATION AND PREVENTIVE MAINTENANCE

ENGINE COOLING

Make sure that the radiator drain cock and the water drain in the cylinder block are closed Plate 7469. Check radiator coolant level and fill to within 1 inch of the top with clean water; or if operation is in cold weather, use a suitable anti-freeze solution.

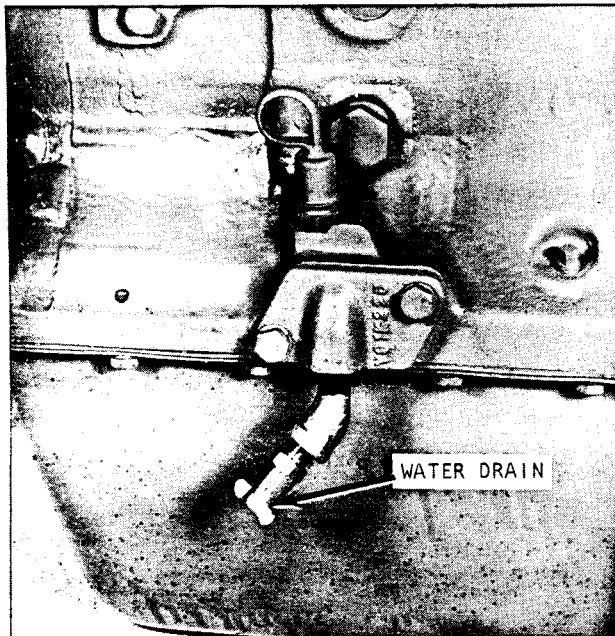

Plate 7469. Cylinder Block Water Drain

It is recommended that a soluble oil in the proportion of 1 ounce per gallon of water be added to the Cooling System.

CAUTION

NEVER POUR COLD WATER OR COLD ANTI-FREEZE INTO THE RADIATOR OF AN OVERHEATED ENGINE. ALLOW THE ENGINE TO COOL AND AVOID THE DANGER OF CRACKING THE CYLINDER HEAD OR BLOCK. KEEP ENGINE RUNNING WHILE ADDING WATER OR ANTI-FREEZE.

CAUTION

WHEN PERMANENT ANTI-FREEZE OF THE ETHYLENE GLYCOL TYPE IS USED, THE COOLANT SOLUTION MUST CONTAIN AT LEAST 40% WATER.

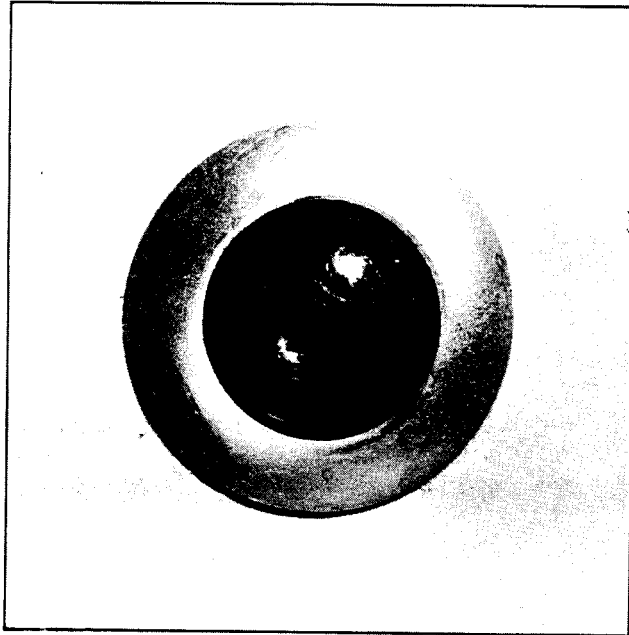

Plate 6885. Oil Pressure
Warning Light

C A U T I O N

IF OIL PRESSURE WARNING LIGHT COMES ON,
STOP THE ENGINE IMMEDIATELY AND FIND THE
CAUSE OF THE TROUBLE. REFER TO TROUBLE
SHOOTING SECTION FOR THIS INFORMATION.

C A U T I O N

ON NEW MACHINES, AFTER STARTING ENGINE --
RUN IT AT IDLE FOR 5 MINUTES, THEN STOP
ENGINE AND RECHECK OIL LEVEL IN CRANKCASE
- BRING OIL LEVEL TO HIGH MARK, IF
NECESSARY.

C A U T I O N

DO NOT IDLE THE ENGINE FOR LONG PERIODS, AS IT
IS NOT ONLY DETRIMENTAL TO THE ENGINE BUT ALSO
INCREASES OPERATING COSTS AS YOU ARE USING FUEL
WITHOUT BENEFIT.

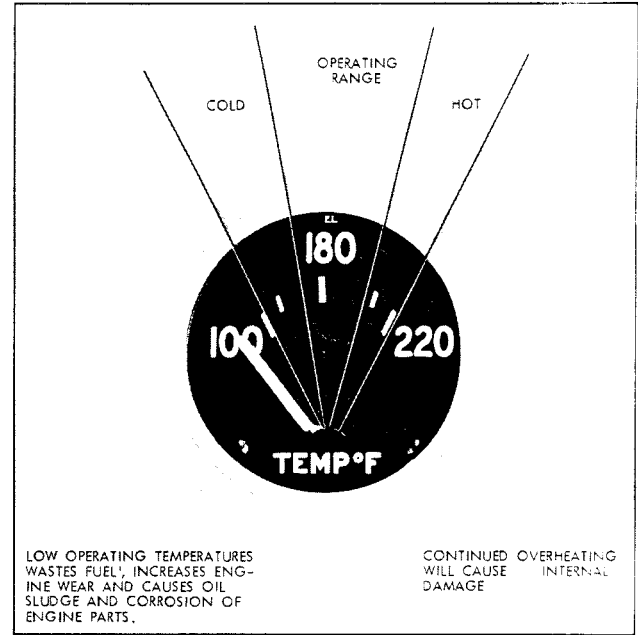

Plate 6287 Engine Coolant
Indicator

N O T E

BEFORE PLACING MACHINE IN OPERATION RUN
ENGINE A FEW MINUTES TO WARM OIL ESPE
CIALLY IN COLD OPERATING CONDITIONS.

LOW OPERATING TEMPERATURES WASTES FUEL AND
INCREASES ENGINE WEAR.

N O T E

THE COOLANT TEMPERATURE SHOULD REGISTER 150°
TO 205° F. AFTER THE FIRST TEN OR FIFTEEN
MINUTES OF OPERATION.

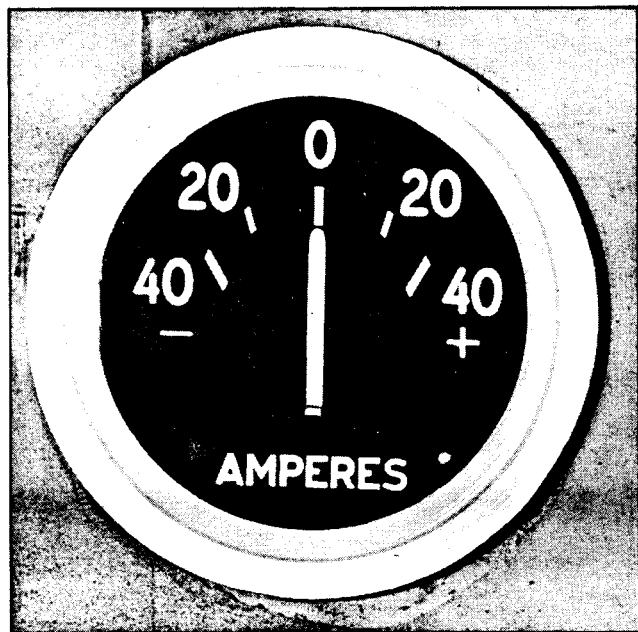

Plate 7647. Ammeter

AMMETER

The ammeter is connected in the generator (or alternator if used) and battery circuit in such a manner as to indicate rate of charge or discharge. If the generator (or alternator) is functioning properly the ammeter should show a small amount of charge at engine idle. As engine R.P.M. increases the rate of charge also increases. When the battery becomes fully charged the circuit is regulated to reduce the rate of charge and cause the ammeter needle to return to near neutral position, showing only a small amount of charge.



Plate 7162. Hour Meter

HOUR METER

The hour meter accurately records the actual hours of machine operation. This will serve as an aid in determining the time intervals for lubrication and preventative maintenance services.

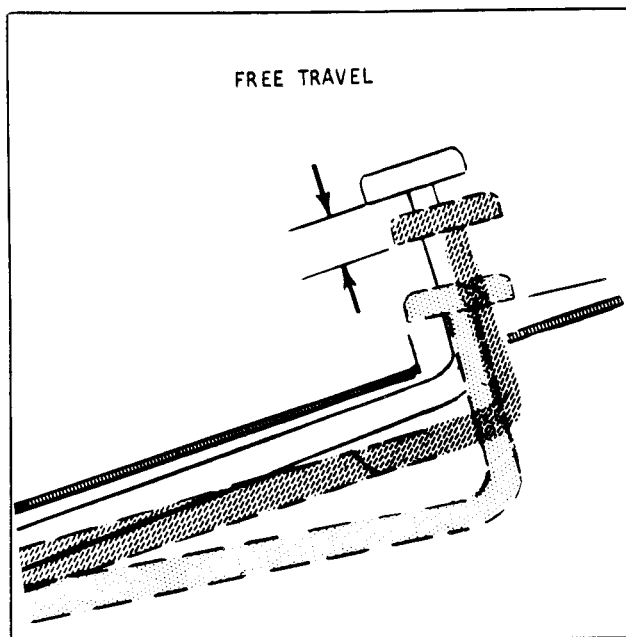

Plate 7048. Right Foot Brake Pedal and Left Foot Inching-Brake Pedal Free Travel Check

RIGHT FOOT BRAKE PEDAL & LEFT FOOT INCHING-BRAKE PEDAL

1. Depress inching-brake pedal by hand. When resistance from the master cylinder is noticed, the distance traveled should be within the limits listed in specifications. If free travel is incorrect an adjustment should be made at the cylinder linkage adjuster.

2. Repeat the above procedure at the right foot brake pedal.

3. Depress each foot pedal and hold for at least 10 seconds. Pedals must be solid, must not be spongy or drift under foot pressure.

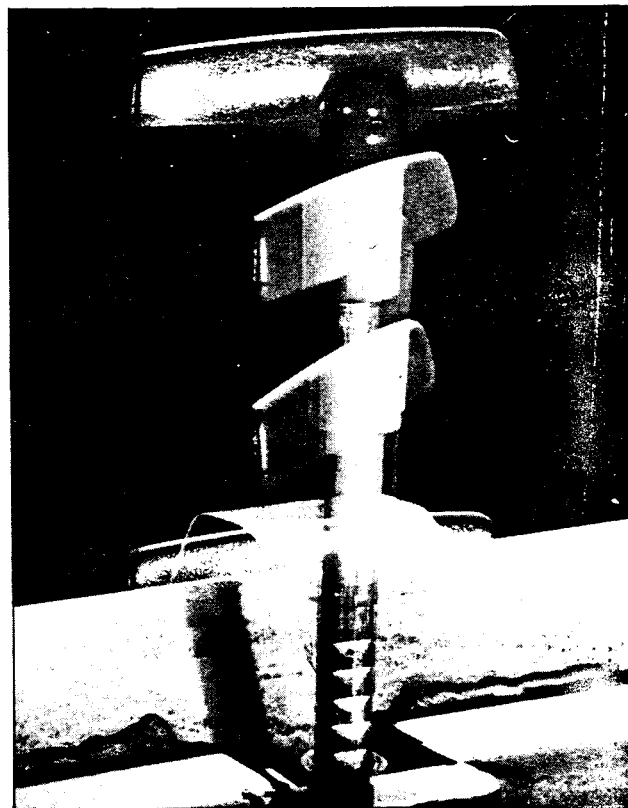

Plate 7482. Parking Brake

PARKING BRAKE

The parking brake linkage should be adjusted so that the brake handle will have 2 inches of upward free travel, before resistance is noticed and the brake becomes applied.

The parking brake must be capable of holding the truck, with full rated load, on a 15% grade. This shall be tested while occupying the driver's seat with the parking brake applied and truck out of gear.

If brake operation is not satisfactory, report to designated person in authority.

LUBRICATION AND PREVENTIVE MAINTENANCE

ENGINE AIR CLEANER (DRY TYPE)

Operating conditions determine the air cleaner service periods. The air cleaner should be checked every 8 operating hours and cleaned. This may be necessary more often under dusty operating conditions.

dirt from entering at these points. Periodically remove hoses and check interior for any signs of dirt or dust. If found, this indicates that more frequent cleaning intervals are necessary as the hose interior should be free of all dirt and dust.

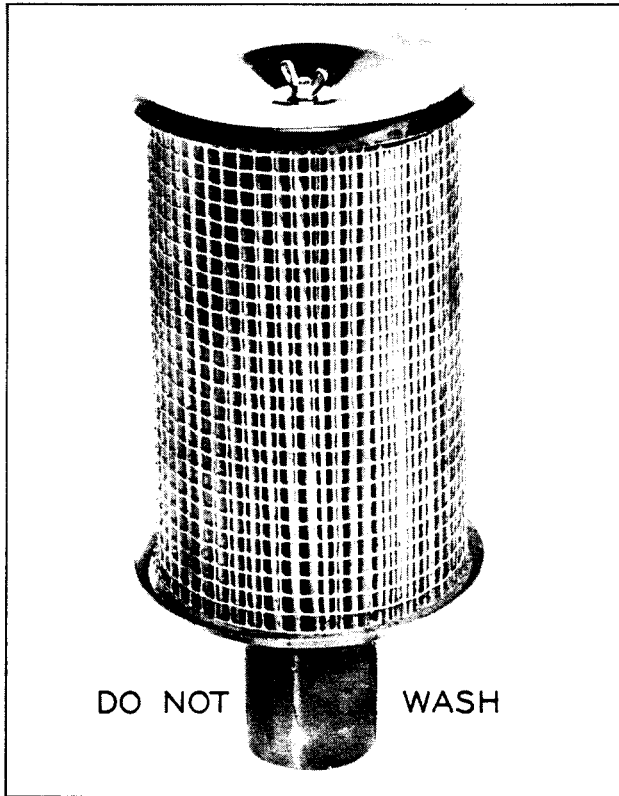

Plate 5697. Air Cleaner

Proper servicing means cleaning unit thoroughly and maintaining air-tight connections between the air cleaner and intake manifold so that all air entering the engine is filtered.

1. Remove air cleaner cartridge (2) and tap cartridge on a hard flat surface until all loose dirt is removed.

2. After cleaning by the above procedure, clean unit with filtered, moisture free, compressed air. Direct air stream from the inside, (thru cartridge) outward at the same time rotating cartridge by hand.

NOTE

IF FILTER CARTRIDGE CANNOT BE PROPERLY CLEANED, REPLACEMENT IS NECESSARY.

Check all hose connections to be sure they are tight thus preventing any air and

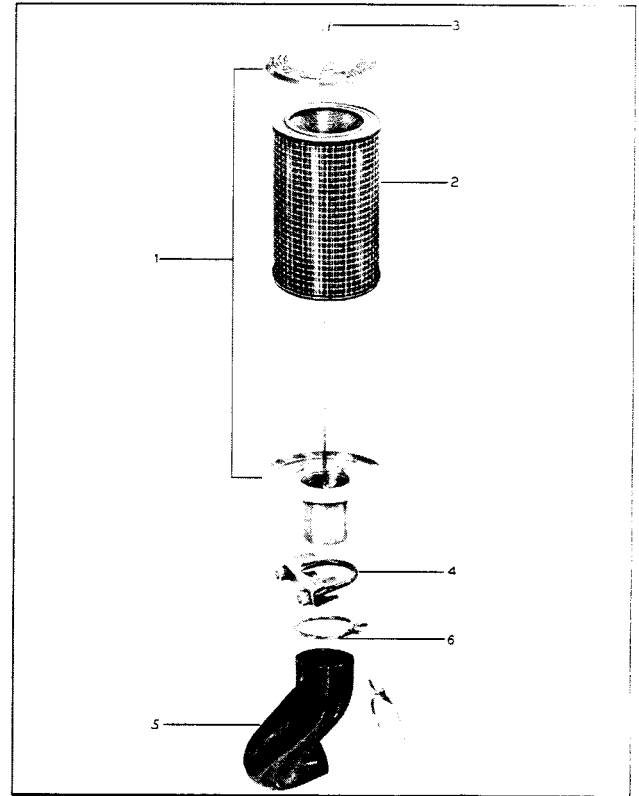

Plate 6980. Air Cleaner Components

NOTE

DEPENDING ON THE TYPE OF OPERATING THE MACHINE IS SUBJECTED TO WILL DETERMINE THE FREQUENCY OF AIR CLEANER MAINTENANCE. HAZARD MAINTENANCE WILL LEAD TO SHORT ENGINE LIFE. AIR CLEANER MAINTENANCE MAY SEEM TRIVIAL, BUT IT CAN MEAN LONGER ENGINE LIFE, LESS ENGINE UPKEEP AND BETTER ECONOMY PROVIDED PROPER MAINTENANCE IS EXERCISED. CLOSE OBSERVANCE AND COMMON SENSE CAN BEST DETERMINE THE FREQUENCY OF AIR CLEANER MAINTENANCE.

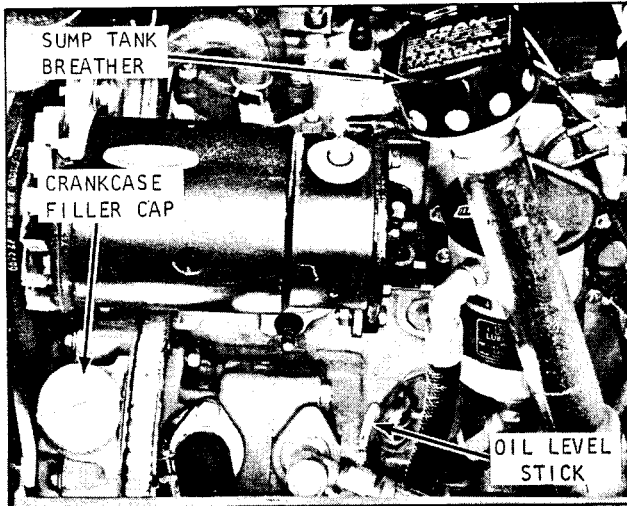

Plate 7758. Sump Tank Breather

HYDRAULIC SUMP TANK

Check hydraulic sump tank fluid level in the following manner:

1. Lower upright.
2. Shut engine off.
3. Remove sump breather. Fluid level should be up to bottom of filler pipe.

If necessary, fill sump tank using MS 68 Hydraulic Oil. Start engine and operate valve control levers allowing any air in the lines to escape, then recheck sump tank fluid level before putting machine into operation.

HYDRAULIC CONTROL LEVERS

I M P O R T A N T

EVERY 8 OPERATING HOURS (OR EVERY SHIFT)

ELEVATE UPRIGHT TO THE UPPER LIMIT. THIS WILL PROVIDE LUBRICATION TO THE TOP PORTION OF THE LIFT CYLINDER.

Check lift and tilt operation. The lift and tilt cylinders should actuate when lift or tilt levers are moved either way from neutral position.

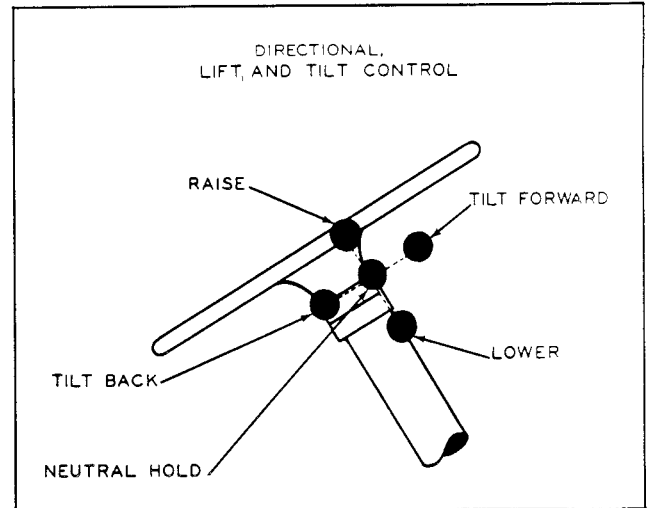

Plate 4448. Lift and Tilt Levers

When load is elevated and control lever returned to neutral position, load should remain in elevated position with no noticeable downward drift. If load drifts downward excessively, this may indicate lift cylinder U-Cup or seal damage -- report to designated person in authority.

With tilt lever in neutral position, upright should remain steady with no noticeable backward or forward drift. If upright drifts excessively either way, this may indicate tilt cylinder seal or U-Cup damage -- report to designated person in authority.

C A U T I O N

NEVER ALLOW LOADED OR UNLOADED LIFT CARRIAGE TO REMAIN IN AN ELEVATED POSITION FOR ANY PROLONGED PERIODS. LIFT CARRIAGE SHOULD BE LOWERED WHEN NOT IN USE.

DO NOT HOLD CONTROL LEVERS IN EXTREME POSITIONS AFTER A LOAD HAS REACHED ITS LIMITS. TO DO SO WILL RESULT IN HIGH OIL PRESSURE THAT MAY RESULT IN HEATING OF THE HYDRAULIC OIL.



INDUSTRIAL TRUCK DIVISION



IMPORTANT

RIM AND WHEEL MAINTENANCE:

N O T E

"In order to maintain and insure maximum service, a continuous maintenance program is advisable... maintenance procedures should be carried out both during tire inspections and during tire changes."

x x		
x	x	
x	W A R N I N G	x
x		x
x	PULL DAMAGED RIMS OR WHEELS. DEFLATE	x
x		x
x	TIRES PRIOR TO THE REMOVAL OF RIMS OR	x
x		x
x	WHEELS FROM THE VEHICLE.	x
x		x
x x		

Check all metal surfaces thoroughly while making tire inspections...watch for...

1. Fatigue cracks in metal.
2. Bent flanges, resulting from road obstructions.
3. Deep rim tool marks.
4. Loose, missing or damaged nuts.
5. Bent or stripped studs.
6. Excessive rust or corrosion.

Mark damaged or hazardous areas with chalk so that part will be removed from service...replace damaged parts.

Insure that replacements are made with the proper sizes and types...refer to your machine serial number when ordering replacement parts. Care should be taken to assure that all replacement parts are interchangeable with the original parts and of a quality equal to that provided in the original equipment.

Check all metal surfaces, as listed above, and check for cracks. These are caused by deep rim tool marks, overloading and overinflating tires and using larger than recommended tire sizes.

Cracks in wheel between stud holes are caused by loose wheel nuts...improper installation procedures and use of incorrect sizes or types of attaching parts. Insufficient mounting torque can cause wheel shimmy, resulting in damage to parts and extreme tire tread wear. Excessive mounting torque can cause studs to break and disc to crack in the stud hole area.

Thoroughly clean wheels...remove rust, dirt and other foreign materials from all surfaces. Hand

or electric wire brushes, and blasting or chemical baths may be used.

Bead seat areas of the rim should be free of rust and rubber deposits. This is especially important for drop-center tubless rims...because of the air-sealing element.

Paint rim by brush or spray with a fast-drying metal primer. Surfaces should be clean and dry prior to painting. Insure that bare metal areas on outside or tire side of rim are covered. This is especially important on drop-center tubless rims, because warm and sometimes moist air is in constant contact with the metal surface on the tire side of the rim.

Lubricate tire side of rim base just prior to mounting tire...avoid the use of any lubricant which contains water or solvent that is injurious to rubber...a combination lubricant and rust-preventive compound is preferable. This protective measure is of particular importance with drop-center tubless rims as the air in the tire is contained by the tire-side rim surface.

N O T E

Rim Distributors can supply the proper compound that serves as a lubricant and rust preventive.

TIRE MAINTENANCE:

Inspect for proper inflation. Refer to Specifications for correct tire pressure.

Inspect tires and wheels regularly for cuts, breaks, alignment, security of wheel clamp bolts (on machine using split rims), and lug nuts or bolts.

Even with the best of maintenance practices, cuts will still be a source of tire trouble. The correct procedure for handling and repairing tires should be given careful attention. Close inspection of all tires should be made at the time of inflation check, and all tires having cuts that penetrate into the cord body should be taken off for proper repair.

Failure to make regular inspections and repairs, when needed, will result in further deterioration of the cord body and eventually a blowout. Small rocks and dirt will get into shallow cuts in the tread and if neglected will gradually be pounded through the cord body.

One simple method to forestall this action is to clean out the cut with an awl or similar tool to remove any stones or other matter which may be lodged in the cut. Use a sharp, narrow-bladed knife and cut away the rubber around the cut to form a cone-shaped cavity extending to the bottom of the injury. The sides of the cavity should be slanted enough to prevent stones from



INDUSTRIAL TRUCK DIVISION



IMPORTANT

TIRE MAINTENANCE (CONTINUED):

wedging into it. Tires with cuts treated in this manner may be continued in service without danger of further growth of these injuries. If a tire has at least one deep cut that requires a repair, then all smaller cuts may be quickly and economically repaired and vulcanized by the steam kettle method.

XXXXXXXXXXXXXXXXXXXXXXXXXXXXXXXXXXXX
X
X WARNING X
X IT IS NOT RECOMMENDED THAT TIRES WITH X
X BREAKS BE USED AGAIN. X
X
XXXXXXXXXXXXXXXXXXXXXXXXXXXXXXXXXXXX

If uneven tire wear is evident, wheel alignment should be checked.

TIRE INFLATION:

Before inflating tires, make certain all wheel nuts are tightened to proper torque (see Specifications).

XXXXXXXXXXXXXXXXXXXXXXXXXXXXXXXXXXXX
X
X WARNING X
X IN ALL CASES, WHEN REMOVING TIRES WITH X
X SPLIT RIMS FROM THE MACHINE FOR REPAIR X
X OR PERIODIC ROTATION, COMPLETELY DEFLATE X
X TIRES. THIS IS ACCOMPLISHED BY REMOVING X
X THE VALVE CORE. X
X
XXXXXXXXXXXXXXXXXXXXXXXXXXXXXXXXXXXX

XXXXXXXXXXXXXXXXXXXXXXXXXXXXXXXXXXXX
X
X WARNING X
X IN ALL CASES, WHEN REMOVING TIRES EQUIPPED X
X WITH THE LOCK RING TYPE RIM FROM THE MA- X
X CHINE FOR REPAIR OR PERIODIC ROTATION, X
X COMPLETELY DEFLATE TIRES. THIS IS ACCOM- X
X PLISHED BY REMOVING THE VALVE CORE. X
X
XXXXXXXXXXXXXXXXXXXXXXXXXXXXXXXXXXXX

XXXXXXXXXXXXXXXXXXXXXXXXXXXXXXXXXXXX
X
X WARNING X
X WHEN REPAIRING TIRES USED ON MACHINES X
X THAT EMPLOY THE LOCK RING TYPE RIM, USE X
X CAUTION WHEN INFLATING TIRE, PROCEED AS X
X FOLLOWS: X
XXXXXXXXXXXXXXXXXXXXXXXXXXXXXXXXXXXX

1. After positioning lock ring on rim, turn wheel and rim assembly over so that lock ring is on side toward ground.
2. Inflate tire to 5 to 10 pounds.
3. Turn rim over and tap lock ring carefully with a mallet to be sure it is properly seated.
4. If you have access to a steel cage...use it. (see next page)...otherwise turn rim and wheel over once again so that lock ring is on the bottom and inflate tire to proper pressure.

XXXXXXXXXXXXXXXXXXXXXXXXXXXXXXXXXXXX
X
X WARNING X
X IF LOCK RING IS NOT LOCATED PROPERLY, IT X
X IS POSSIBLE FOR IT TO POP OFF RIM WITH X
X GREAT FORCE WHEN TIRE IS INFLATED AND X
X COULD RESULT IN SERIOUS INJURY TO ANYONE X
X STRUCK BY IT. X
XXXXXXXXXXXXXXXXXXXXXXXXXXXXXXXXXXXX

On machine using split rims, make periodic checks for noises in the wheel, as it is possible for damage to occur to the wheel bolts if they are not securely tightened when tires are changed. If the wheel bolts are loose or have been sheared off as a result of being loose, a grinding or scraping noise will be present when wheels are turned. Should this condition exist, it will be necessary to immediately remove the rim and tire from the machine and determine the cause of noise and repair or replace defective parts.

NOTE

Refer to WARNING on deflation of tires before removing wheels from machine.

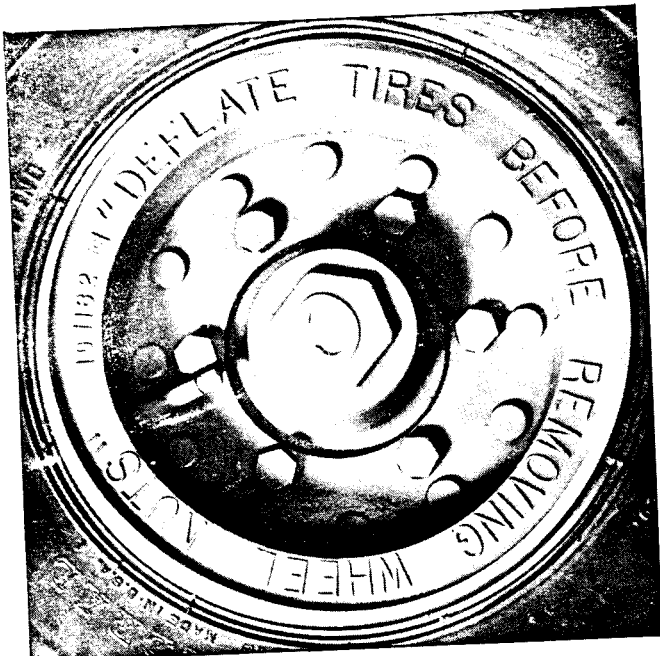

Plate 7613. Typical Split Wheel

seated prior to inflation. An inflated tire contains potentially explosive energy that can blow rings loose.

All wheel/tire assemblies should be inflated in a safety cage. The air hose should have a special set-up as shown in Plate 9702. The hose should have an adapter so that it can be securely fastened to the valve stem. Using this set-up you would:

1. Attach air hose to valve stem.
2. Open shut-off valve allowing compressed air to enter tube.
3. Shut off air supply occasionally to check pressure in tube at air gauge.
4. Inflate to proper capacity. If pressure exceeds proper inflation capacity, depress the relief valve to release excess air pressure.
5. This alternating procedure is followed until proper inflation is reached. See specifications.

I M P O R T A N T

MAINTAIN UNIFORM INFLATION IN BOTH TIRES OF A DUAL ASSEMBLY SO THAT WEIGHT IS EQUALLY SUSTAINED. NEVER RE-INFLATE A TIRE THAT HAS GONE FLAT WITHOUT FIRST INSPECTING IT AND THE WHEEL ASSEMBLY.

The tire inflation arrangement as shown in Plate 9702 can be made up from local suppliers.

Parts can be ordered from the following suppliers:

Relief Valve - Model 250V-1/4"

Humphrey Products
P.O. Box 2008
Kilgore at Sprinkle Rd.
Kalamazoo, Mich.

Shut-Off Valve - Imperial #77E (1/4" to 1/4" 1 PT)

Kendall Industrial Supplies, Inc.
702 N. 20th St.
Battle Creek, Mich. 49016

Air Gauge - Marshaltown #23 (160 lb., 1/4" 1 PT, 2 1/2" diameter gauge)

Kendall Industrial Supplies, Inc.
702 N. 20th St.
Battle Creek, Mich. 49016

Safety Cage

Meyers Tire Supplies
6400 Epworth Blvd.
Detroit, Mich.

DIRECTIONAL TREAD TIRES

All directional tread tires are to be mounted in the correct position with respect to the arrow cast on the side of the tire as explained and illustrated below.

Directional Tread Dual Tires:

1. Inside dual tire arrow to point in the direction of forward rotation, see Plate 6422.

(Rotate wheel to bring arrow on tire above the wheel. Arrow must point toward front of truck.)

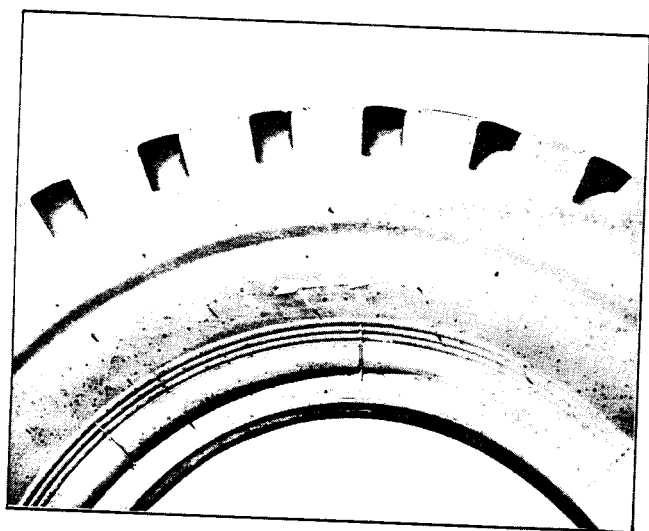

Plate 6422. Inside Dual Tire
(or Single Drive Tire)
(Arrow to point toward front of truck)

2. Outside dual tire arrow to point in the direction of rearward rotation, see Plate 6423.

(Rotate wheel to bring arrow on tire above the wheel. Arrow must point toward rear of truck.)

Directional Tread Single Drive Tires:

1. Tire arrow to point in the direction of forward rotation, see Plate 6422.

(Rotate wheel to bring arrow on tire above the wheel. Arrow must point toward front of truck, see Plate 6422.)

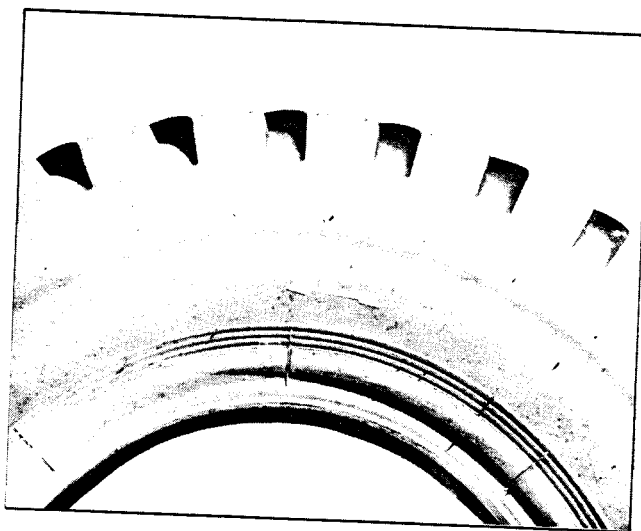

Plate 6423. Outside Dual Tire
(Arrow to point toward rear of truck)

SOLID OR CUSHION TIRE AND RIM MAINTENANCE

1. Inspect tires regularly - remove all sharp objects picked up by treads before they have a chance to cut further into the rubber and cause chipping or possible separation of the rubber from the base metal.
2. Avoid overloading and do not allow vehicle to stand under heavy loads for prolonged periods as this will cause a "flat" spot on the tires.
3. Check steering axle alignment regularly to protect against fast, irregular tread wear and separation.
4. If rubber tires come in contact with oils, grease, and gasoline they should be wiped off without delay.
5. Regular lubrication of all wheel bearings will assure free-rolling and elimination of tire drag when stopping or starting.

100 HOURS

LUBRICATE MACHINE

LIFT CHAINS INSPECT, LUBRICATE & ADJUST. USE CHAIN LUBE CLARK NUMBER 886399. NOTE: When Operating In Abrasive Atmosphere, Keep Lift Chains Free Of Lubricant.

HYDRAULIC VALVE & LINES INSPECT.

INCHING-BRAKE PEDAL FREE TRAVEL ADJUST.

STEERING GEAR LEVEL CHECK.

ENGINE CRANKCASE VENT PIPE INSPECT.

FUEL TANK AND LINES INSPECT.

COOLING SYSTEM INSPECT.

WATER PUMP INSPECT.

LIFT CYLINDER INSPECT.

BRAKE PEDAL FREE TRAVEL CHECK & ADJUST.

TILT CYLINDERS INSPECT.

LIFT CARRIAGE INSPECT.

TRANSMISSION & AXLE ADAPTER LEVEL CHECK.

BRAKE SYSTEM CHECK.

BATTERY CHECK.

NOTE

ENGINE CRANKCASE DRAIN - REFILL

ENGINE OIL FILTER ELEMENT - CHANGE

FAN & GENERATOR DRIVE BELTS INSPECT & ADJUST.

IN ADDITION TO THE ABOVE, PERFORM THE 8 HOUR PREVENTIVE MAINTENANCE SERVICES

SUMP TANK BREATHER - SERVICE.

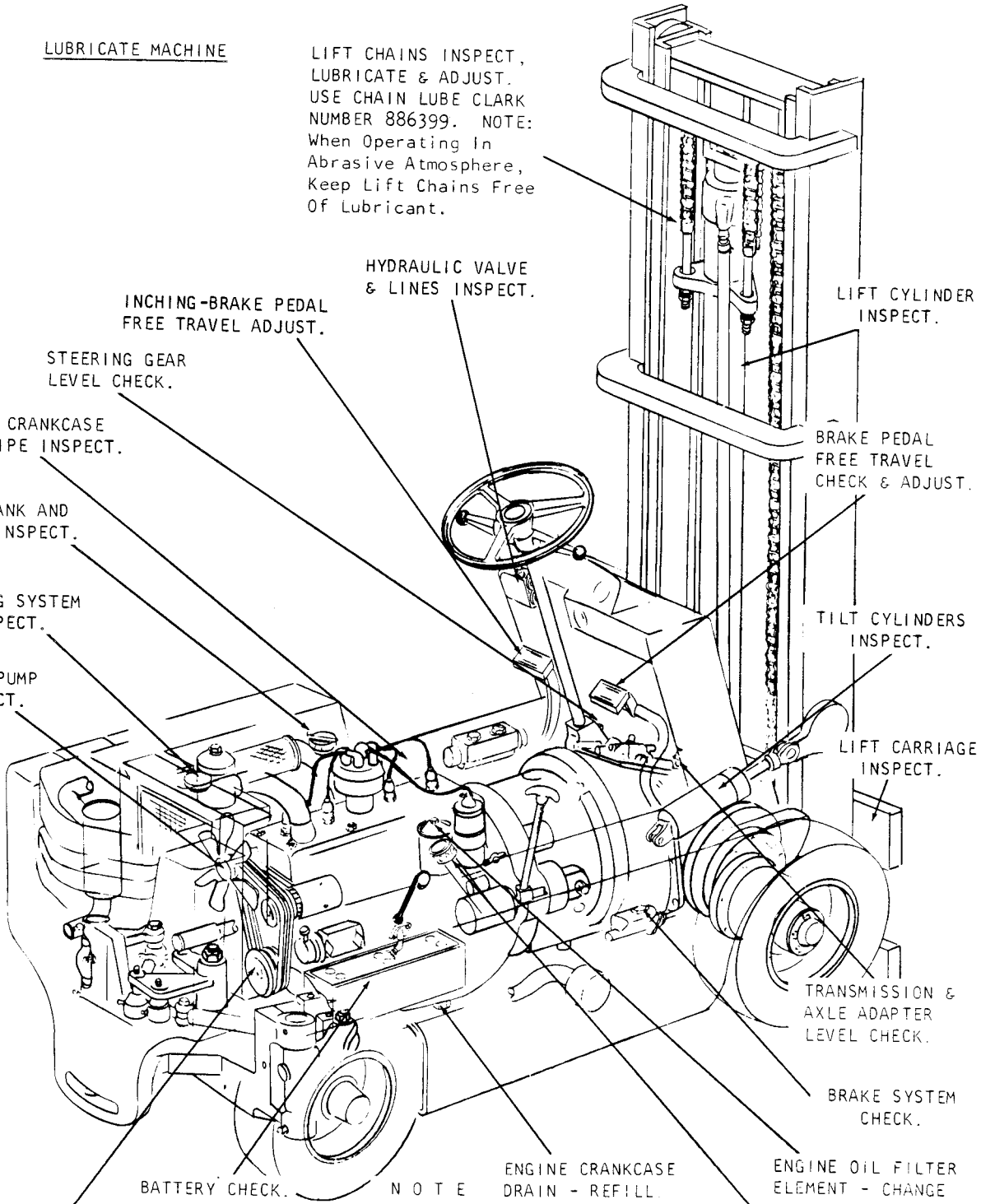

Plate 7993. Lubrication and Preventive Maintenance Illustration

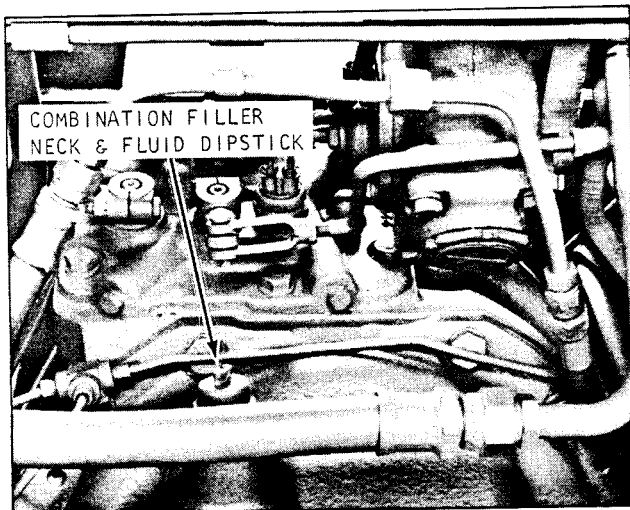

Plate 7762. Transmission Dipstick

CONVERTER, TRANSMISSION AND AXLE ADAPTER HOUSING.

Verify fluid level, fill if necessary with Automatic Transmission Fluid Type "A" Armour Qualified (Clark Part # 879803). A combination filler neck and fluid level stick is provided in the Transmission Axle Adaptor Housing for filling or checking fluid level.

With directional selector in "NEUTRAL" position, start engine and operate approximately four minutes. Stop engine and check fluid level. Fill if necessary to "FULL" mark on fluid level stick.

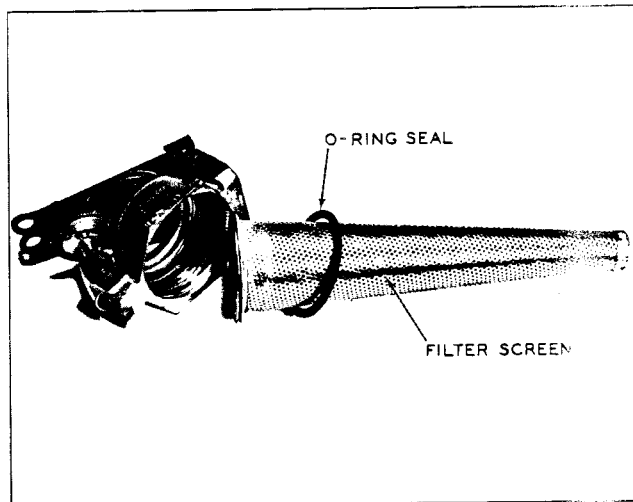

Plate 6627. Fuel Tank Filler Cap and Screen

FUEL LINES

Make certain that fuel line connections are secure. Check fuel lines for obstructions and leaks. Check screen in fuel filler cap (machines so equipped) to make certain that it is properly installed.

W A R N I N G

THE FUEL TANK IS AN INTEGRAL PART OF THE MACHINE FRAME AND ANY WELDING IN THIS AREA SHALL NOT BE ATTEMPTED WITHOUT FIRST TAKING ADEQUATE SAFETY PRECAUTIONS.

ENGINE CRANKCASE

Every 100 operating hours, drain and refill. (Drain at operating temperatures). Refill, then run engine a few minutes and add oil as necessary to bring oil level to full mark indicated on the dipstick.

Crankcase Capacity — Refer to Specifications

Service "MS" Oils
 S.A.E. 10W 0° to 32° F.
 S.A.E. 20W 32° to 75° F.
 S.A.E. 30 above 75° F.
 or use 10W...30 MULTI-GRADE OIL.

ENGINE CRANKCASE VENTILATION PIPE

Check crankcase ventilation pipe for damage or obstructions. The pipe must be open to provide proper ventilation. Clean, repair or replace as required.

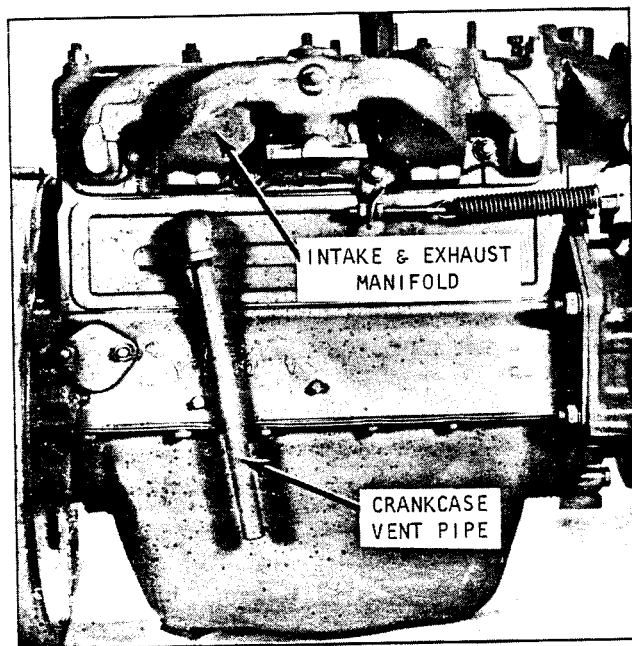

Plate 7470. Crankcase Vent Pipe

ENGINE OIL FILTER

The oil filter element is of the replaceable type. The element should be changed whenever the crankcase is drained. To remove the element, remove oil filter cover screw and gasket, oil filter cover, cover spring and cover gasket. Lift out oil filter element. Install new element after draining and thoroughly cleaning filter case. Install new gaskets and replace cover spring, oil filter cover and secure with oil filter cover screw.

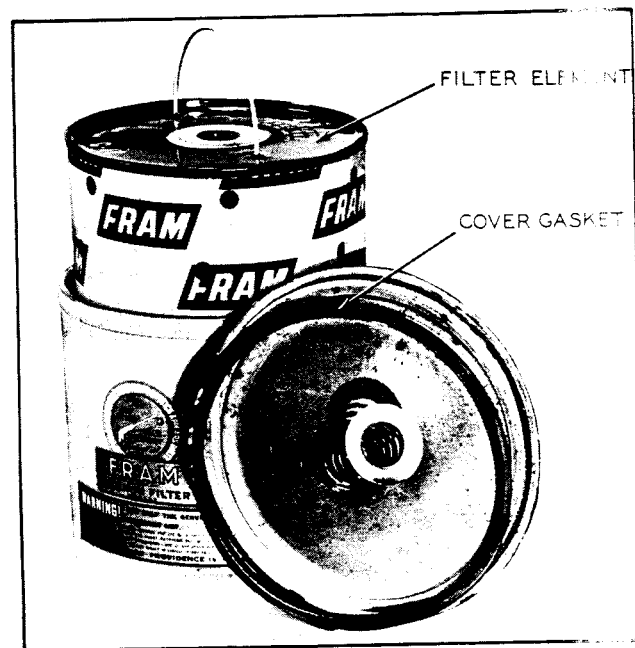

Plate 6642. Engine Oil Filter

CAUTION

START ENGINE. RUN AT IDLE FOR A FEW MINUTES, CHECK COVER AND COVER SCREW LEAKS.



Plate 6458. Radiator Pressure Cap

W A R N I N G

USE EXTREME CARE IN REMOVING THE RADIATOR PRESSURE CAP. IN PRESSURE SYSTEMS, THE SUDDEN RELEASE OF PRESSURE CAN CAUSE A STEAM FLASH AND THE FLASH, OR THE LOOSENED CAP CAN CAUSE SERIOUS PERSONAL INJURY. LOOSEN CAP SLOWLY AND ALLOW STEAM TO ESCAPE. THIS MACHINE IS EQUIPPED WITH A 7 LB PRESSURE CAP.

COOLING SYSTEM

Check radiator, hoses and water pump for leaks.

Add proper amount of water or anti-freeze solution to cooling system. If anti-freeze is not available and machine is to be at rest for an appreciable length of time, drain system when temperature is likely to be 32° F, or lower. If water is added to radiator containing anti-freeze solution, always test solution in radiator with a hydrometer to determine the degree of protection. For proper amount of anti-freeze solution required to protect the cooling system, refer to instructions on anti-freeze container.

N O T E

COOLING SYSTEM CAPACITY - REFER TO SPECIFICATIONS.

Accumulated foreign material should be blown from radiator fins with compressed air. Direct air stream through radiator fins towards engine to make this procedure effective.

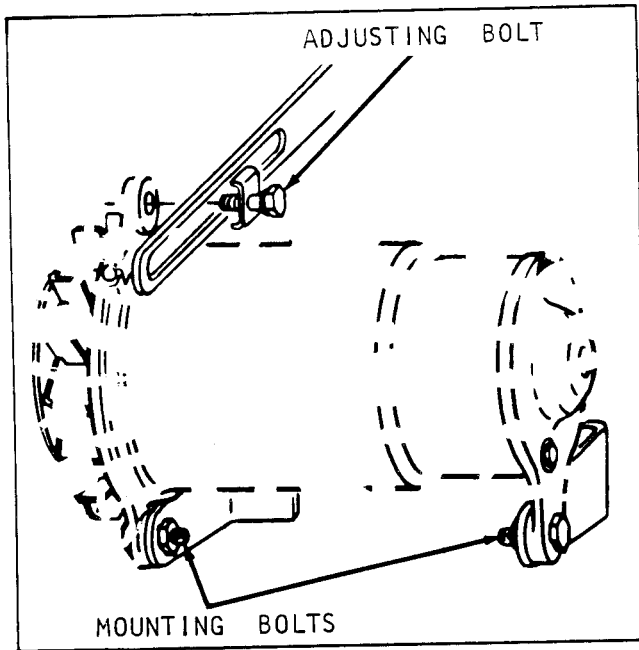

Plate 6631. Generator Drive Belt Adjustment
FAN AND GENERATOR DRIVE BELTS

The drive belts should have finger pressure deflection of 3/4 to 1 inch mid-way on long span. If belts require adjustment, use following procedure.

1. Loosen generator brace adjusting bolt and two lower mounting bolts, see Plate 6631.
2. Move generator toward cylinder block to loosen Generator Drive Belts and away from cylinder block to tighten belts. Tighten bolts when correct finger deflection is obtained.

C A U T I O N

EXERCISE CAUTION WHEN ADJUSTING BELTS. BELTS ADJUSTED TOO TIGHT WILL VERY LIKELY CAUSE

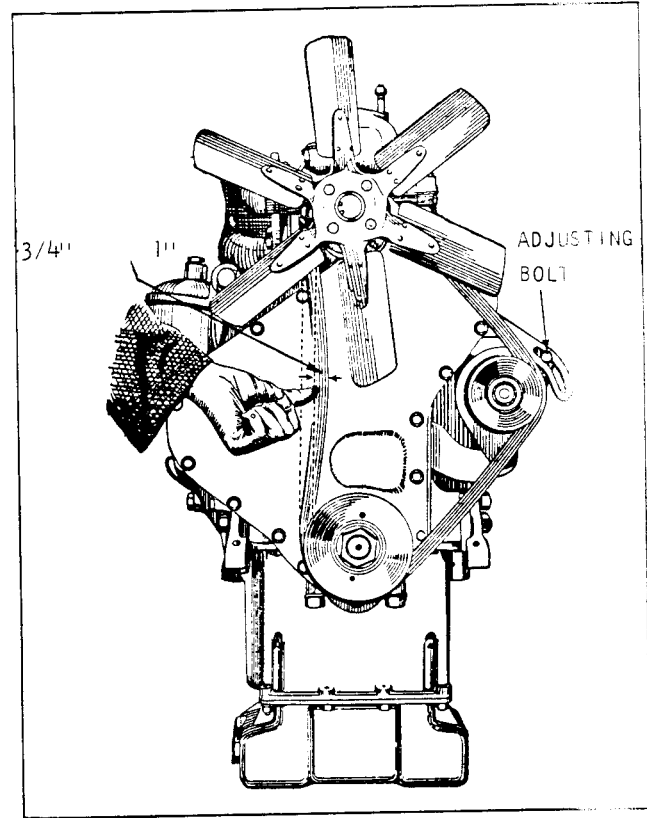

Plate 6632. Belt Deflection Check
BEARING DAMAGE. CONVERSELY, BELTS ADJUSTED TOO LOOSE WILL RESULT IN BELT WEAR AND HIGH ENGINE TEMPERATURE DUE TO BELT SLIP-PAGE.

N O T E

UPON REPLACEMENT OF DRIVE BELTS, IT WILL BE NECESSARY TO USE A MATCHED SET OF BELTS.

BRAKE PEDAL FREE TRAVEL

1. Check the distance between the pedal pads and the floorplate as shown on Plate 7940. If the dimension is incorrect, remove the floorplate and adjust the pedal stops to obtain the correct distance.

2. Check the free travel of each pedal by depressing it by hand. The free travel of the pedals is the distance from top pedal position to a point where resistance is noticed from its respective master cylinder. See Plate 7940. Adjust each master cylinder rod as shown on the following page (Plate 5065) to obtain the correct free travel. Shorten the rod to increase free travel and lengthen the rod to decrease free travel.

BRAKE ACTUATION STROKE

The automatic brake adjusters will maintain pedal stroke, with little variation, until such time as the brake linings require replacement. If during brake application, the pedal is found to have excessive travel, the complete brake system should be checked and the necessary corrections made to restore adequate and safe braking ability.

WARNING

CORRECT BRAKE PEDAL FREE TRAVEL IS IMPORTANT FOR SAFE OPERATING BRAKES.

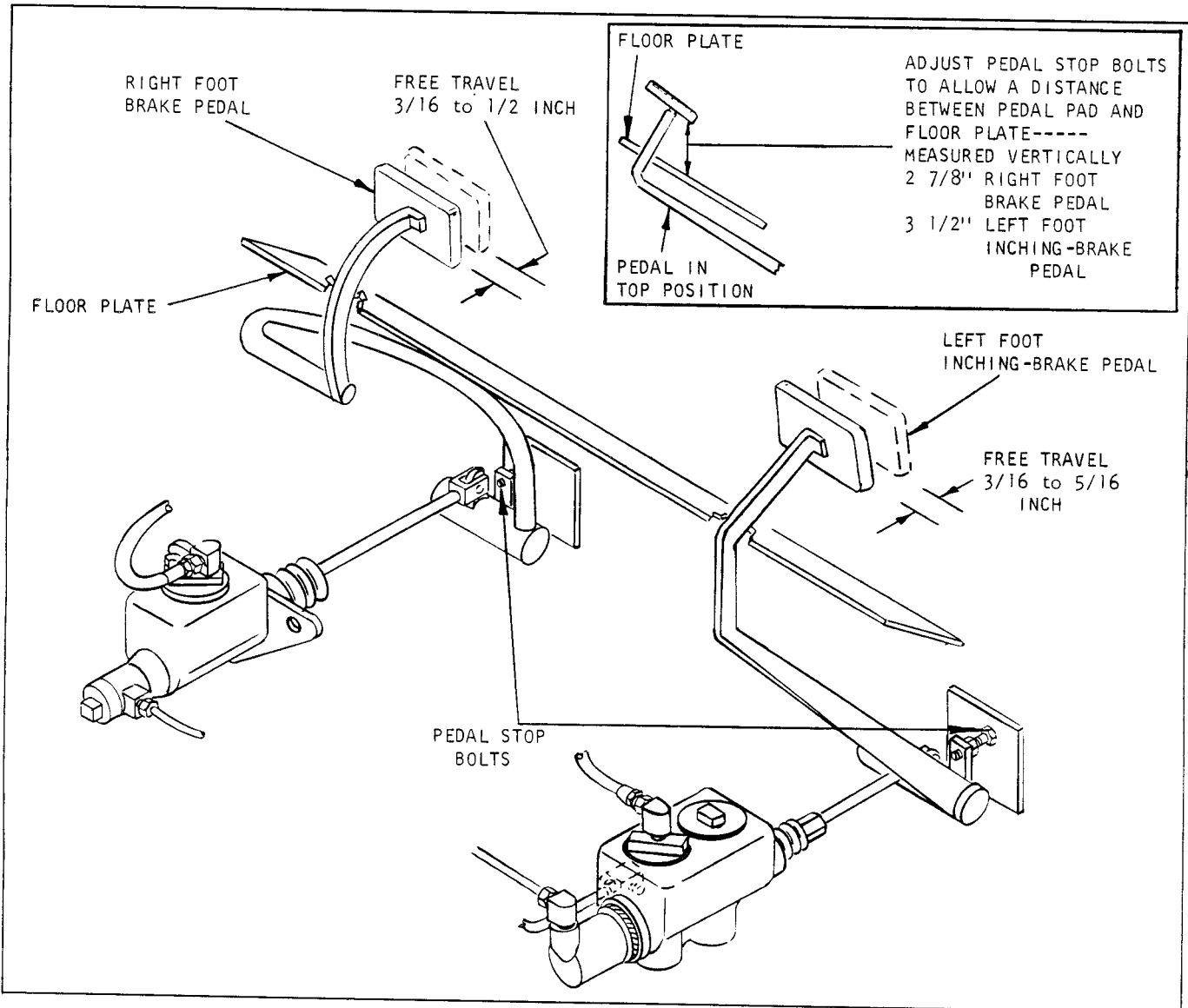

Plate 7940. Pedal Height and Free Travel Adjustment

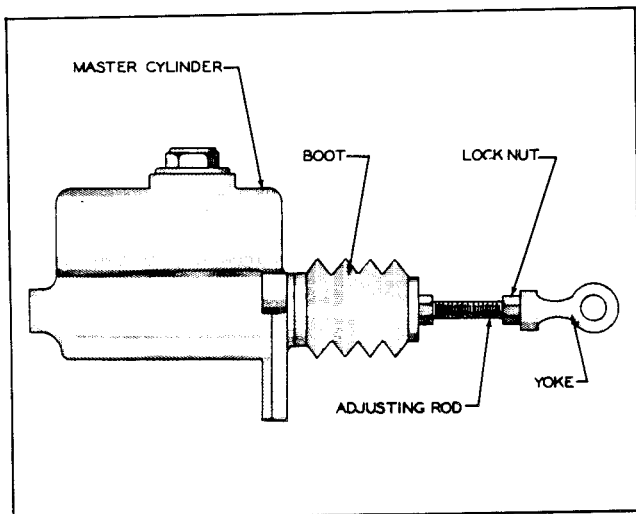

Plate 5065. Typical Master Cylinder Free Travel Adjustment

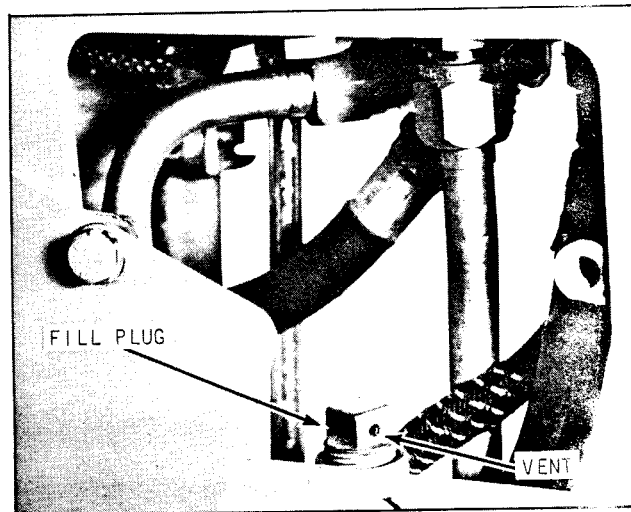

Plate 7941. Brake System Fill Plug

BRAKE SYSTEM

Check brake fluid supply for the master cylinders. Fill with S.A.E. 70R3 Heavy Duty Brake Fluid (Clark #1800200) in the following manner:

1. Remove fill plug located behind the access panel on the cowl. See Plate 7941.

2. Loosen cylinder cap "A" and plug "B" (Plate 7940). Fill through the fill plug opening until fluid flowing from the loosened cap and plug is free of all traces of air.

3. Tighten cylinder cap "A" and plug "B". Check fill plug vent hole for obstruction. Vent hole must be open at all times. Clean if necessary, see Plate 7941. Replace vent plug and cowl access panel to complete the filling procedure.

HYDRAULIC SUMP TANK BREATHER

Unscrew breather from sump tank fill pipe and shake out accumulated dirt. If breather is clogged with foreign matter that cannot properly be removed, the breather should be discarded and the installation of a new breather is necessary. (Clark part number 674905.)

NOTE

UNDER EXTREME DUSTY CONDITIONS IT MAY BE NECESSARY TO CLEAN OR REPLACE BREATHER MORE FREQUENTLY.

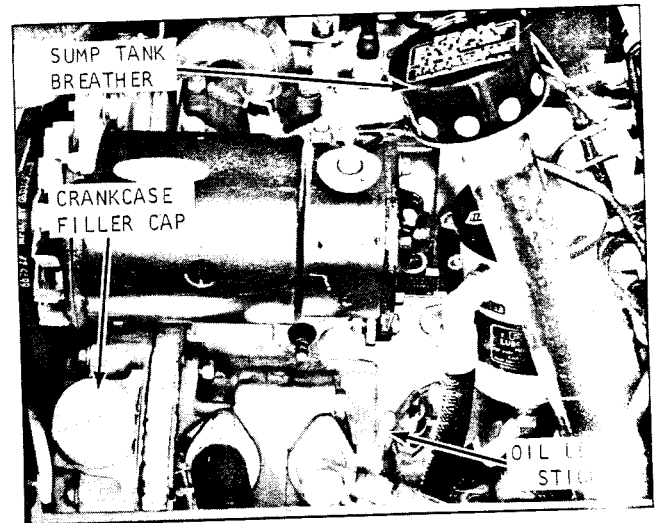

Plate 7758. Hydraulic Sump Tank Breather

BATTERY INSPECTION

Remove all caps and check fluid level. Keep the fluid in each battery cell above the plates or up to the level ring in the bottom of the filler well. Use only pure distilled water. If the machine is exposed to freezing temperatures, operate the engine for a period of time to make sure the added water mixes thoroughly with the battery electrolyte solution. Otherwise, the water may freeze and damage the battery.

x
 x
 x W A R N I N G x
 x x x
 x NEVER ALLOW FLAME OR SPARKS NEAR THE x
 x x x
 x BATTERY FILLER HOLES BECAUSE EXPLOSIVE x
 x x x
 x HYDROGEN GAS MAY BE PRESENT. x
 x x x
 x

Take hydrometer reading of electrolyte to determine state of charge. Charge battery if reading is below 1.225 at 24 deg. C (75 deg. F), or below 1.265, if machine is exposed to freezing temperatures. If machine is operating in tropical areas in which freezing weather is not encountered, the full charge specific gravity reading may be lowered from 1.375 to 1.225 by diluting the electrolyte with distilled water.

N O T E

Add distilled water before charging. Do not add distilled water immediately after a charge.

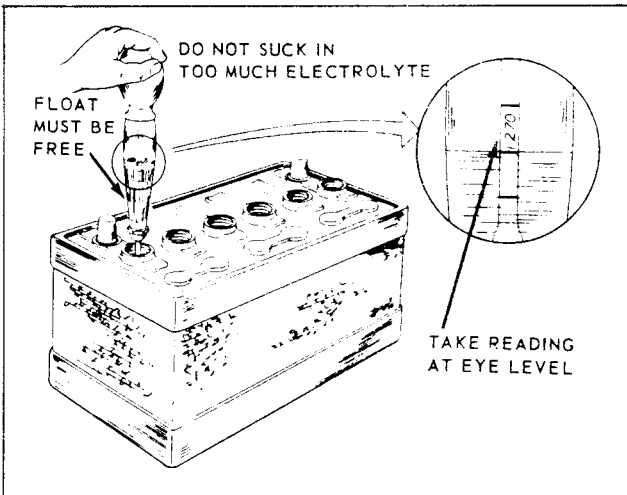

Plate 6271. Checking Specific Gravity of Battery

Make sure that all connections are tight at battery, starter, generator/alternator voltage

regulator, distributor and spark plugs. Corrosion can be removed from the battery cables and terminals with a solution of baking soda or ammonia and water. After cleaning, flush the top of the battery with clean water, and coat the parts with grease to retard further corrosion.

BATTERY TEST PROCEDURE

A defective battery or a discharged battery may be found by performing the following "Light Load Test".

1. Place an electrical load on the battery by cranking the engine for three seconds. If it starts, turn the ignition off immediately.
2. Place a 10 ampere load across the battery terminals for one minute. This will condition the battery so an accurate voltage comparison test can be made between cells. (Connecting two headlights turned on low beam will equal the 10 ampere load - this method may be used in place of the load placed across the terminals.)

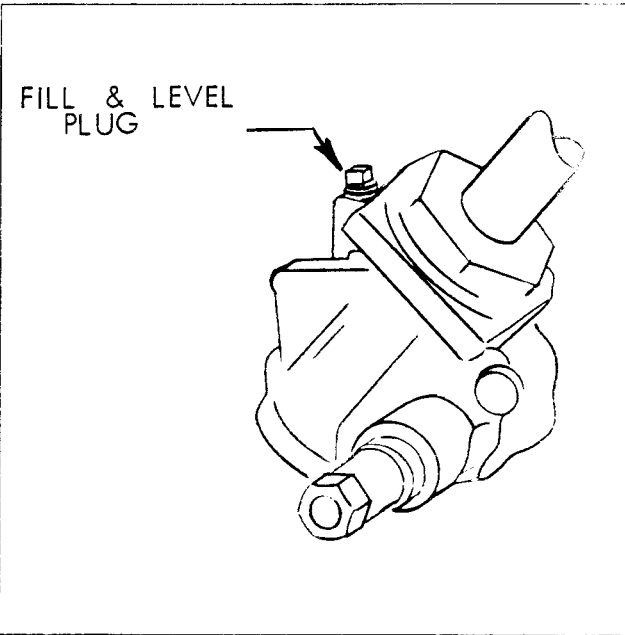

Plate 6429. Typical Steering Gear

STEERING GEAR

The steering gear is prepacked with grease at the factory and should not require lubrication until disassembled for repair. However, it is recommended that periodically the gear be checked for proper lubricant level, and filled if necessary with NLGI #1 (amoloth grease EP #1 or its equivalent).

LUBRICATION AND PREVENTIVE MAINTENANCE

NOTE: WIPE ALL DIRT FROM FITTINGS BEFORE APPLYING A GREASE GUN

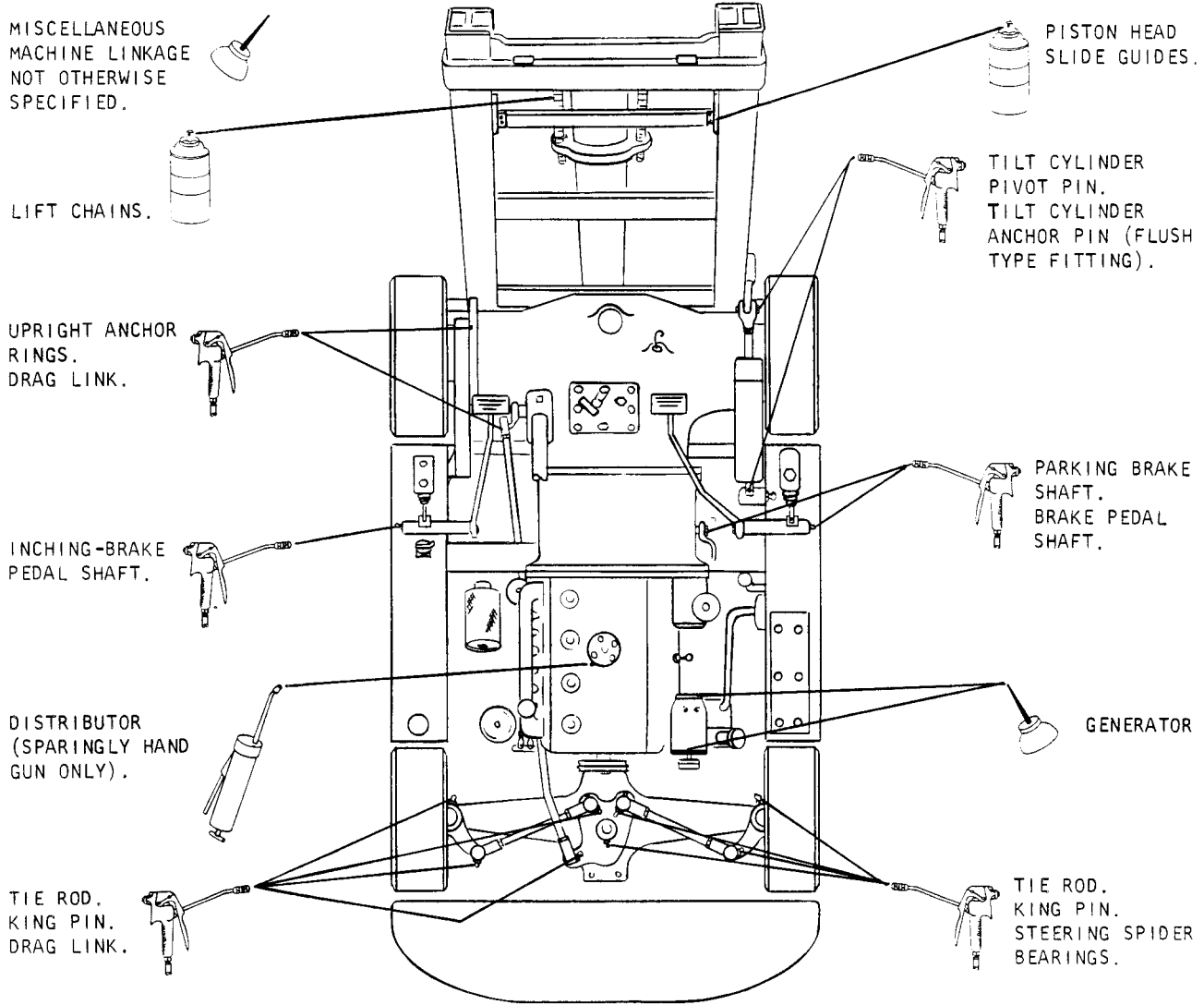

LUBRICATION CHART KEY

ENGINE OIL: S.A.E. 20



SLIDING TANDEM LUBE
PART # 886396

CHAIN LUBE
PART # 886399



CHASSIS GREASE



CHASSIS GREASE

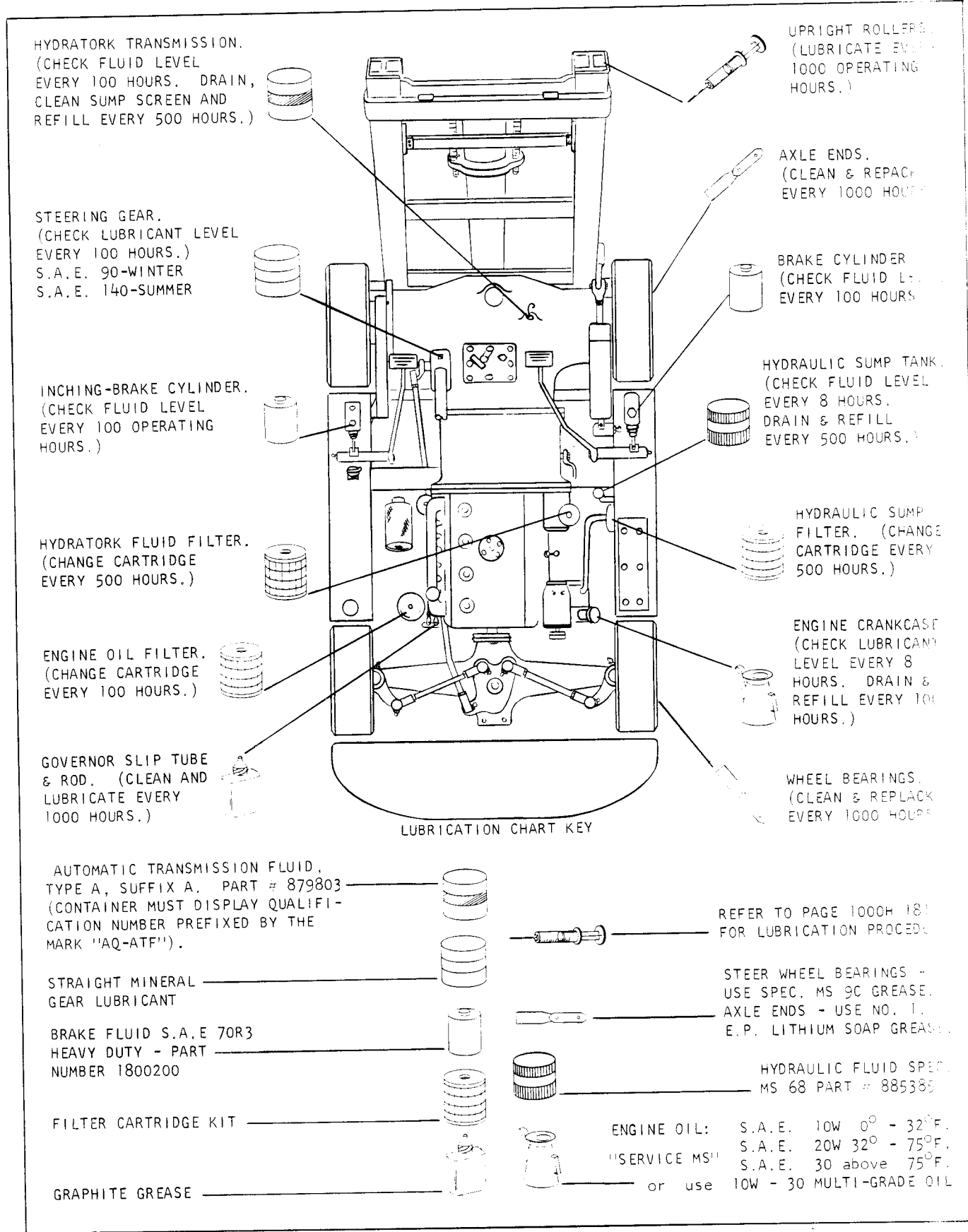



INDUSTRIAL TRUCK DIVISION



LUBRICATION SPECIFICATIONS

LUBRICATION CHART KEY

(A) ENGINE CRANKCASE OIL

FOR ... GASOLINE, L.P. GAS
ENGINES AND NATURALLY
ASPIRATED DIESEL ENGINES.

SPECIFICATION TO MEET API Service Classification "CC" and "SC" per SAE Report J183 and/or MIL-L-2104B* Sulfated ash content 1.00% weight maximum. Zinc content 0.06 to 0.10% weight maximum.

This specification includes oils meeting Specification MIL-L-46152 when applicable. Also, API Service "SC"/"SD" (Formerly "MS") oils may be preferred under stop-and-go or light service conditions.

*Although Specification MIL-L-2104B has recently been superceded, oils of this quality will continue to be available.

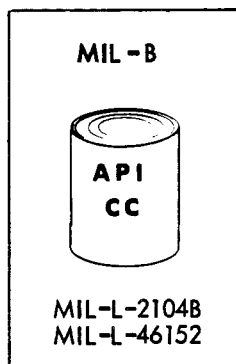

TYPICAL PRODUCT RECOMMENDED BY MAJOR BRAND OIL SUPPLIERS

Chevron RPM DELO Multi-Service Oil
Shell X-100 or Rotella, Rotella T
Sunfleet H.P. Motor Oil
ARCO Fleet X.H.D. Motor Oil
or ARCO Fleet H.D.
Gulflube Motor Oil X.H.D.
Citgo C300 Motor Oil
AMOCO 200 Motor Oil
Texaco Havoline
or URSA Extra Duty Motor Oil
Mobil Delvac 1100B
or 1200 Series Motor Oil
...or the equivalent to the above.

OILS FORMULATED FOR L.P.G. ENGINES

Cito L.P. Gas Engine Oil
Chevron Gas Engine Oil HDAX

(B) ENGINE CRANKCASE OIL (cont.)

FOR ... TURBOCHARGED DIESEL ENGINES
or DIESEL ENGINES USING
HIGH SULFUR CONTENT FUEL
(OVER 0.5% SULFUR).

SPECIFICATION TO MEET API Service Classification "CD" per SAE Report J183 and equivalent Series 3 and/or MIL-L-45199B specifications. Also MIL-L-2104C when applicable. Sulfated ash content 1.65% maximum.

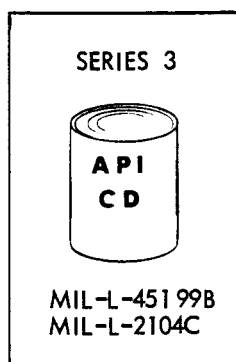

Chevron DELO Super 3 Oil
Shell Rimula Motor Oil
Sunfleet S-3 Motor Oil
ARCO Fleet MS-3 Motor Oil
Gulf Super Duty Motor Oil
AMOCO 300 Motor Oil
Citgo C-500 Motor Oil
Texaco URSA LA-3 Motor Oil
Mobil Delvac 1300 Series Motor Oil
...or the equivalent to the above.

FOR ALL OPERATIONS WITHIN NOMINAL TEMPERATURE RANGES, THE USE OF SINGLE-GRADED OILS IS RECOMMENDED...AS LISTED BELOW.

SAE 10W	...	0 deg -to- 32 deg F.
SAE 20/20W	...	33 deg -to- 75 deg F.
SAE 30	...	above 75 deg F.

SAE #30 OIL OF MIL-L-2104B PERFORMANCE LEVEL IS RECOMMENDED FOR YEAR AROUND USE IN DETROIT DIESEL ENGINES...(Limitations - Zinc . 0.10% maximum, sulfated ash 1.0% maximum.). The use of Multi-grade oils in Detroit Diesel engines is not recommended.

Oil Change Intervals ... a helpful guide in determining the intervals is an engine oil analysis made several different times. Local oil distributors offer this service. And by using it you can set P.M. intervals with greater certainty.



INDUSTRIAL TRUCK DIVISION



LUBRICATION SPECIFICATIONS

LUBRICATION CHART KEY

(A/B) ENGINE CRANKCASE OIL
FOR ... MISCELLANEOUS LINKAGE

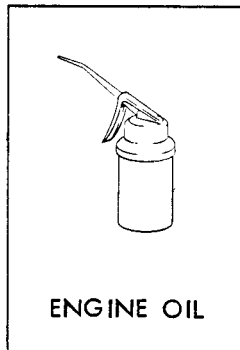

TYPICAL PRODUCT RECOMMENDED BY
MAJOR BRAND OIL SUPPLIERS

(C) TRANSMISSION LUBRICANT
FOR ... STANDARD MANUAL SHIFT
(SYNCHROMESH) TRANSMISSIONS
AND GEAR BOXES.

SPECIFICATION Regular type gear
lubricant of straight mineral gear
oil for API GL-1 Service per SAE
Report J308a. ("EP" lubricants
are not approved.)

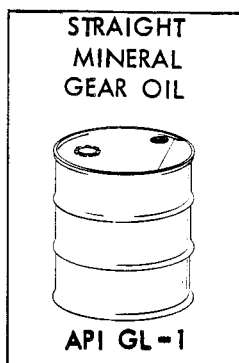

Chevron RPM Gear Oil
Shell Dentax 90 Gear Oil
Sunoco Gear Oil
ARCO Mineral Gear Oil
Gulf Transmission Oil
AMOCO Gear Lubricant
Citgo Regular Gear Oil
Texaco Thuban 90
Mobilube C Gear Oil
Molub-Alloy Trans., Gear Lube
...or the equivalent to the above.

ABOVE 0 deg F. - SAE #90
BELOW 0 deg F. - SAE #80

(D) TRANSMISSION FLUID

FOR ...
...POWRSHIFT FORWARD & REVERSE UNIT
...POWRWORKER HYDRAULIC SYSTEMS
...POWER STEERING RESERVOIRS
...POWRSHIFT TRANSMISSIONS
...HYDRACOO (WET) CLUTCH TRANS.
...HYDRATORCK TRANSMISSION
...AUTOMATIC TRANSMISSION
...FLUID COUPLING DRIVES
...TORQUE CONVERTERS
...ELECTRIC TRUCK DRIVE UNITS*
...(WHEN SPECIFIED ON LUBE CHARTS*)
...NARROW AISLE TRUCK HYDRAULIC SYS.

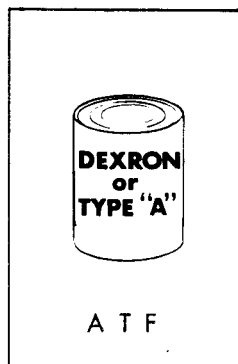

Shell Auto. Trans. Fluid Donax T-6,
Dexron.
Sunoco Auto. Trans. Fluid, Dexron.
ARCO Auto. Trans. Fluid, Dexron.
Gulf Auto. Trans. Fluid, Dexron.
Mobil Auto. Trans. Fluid 220
Dexron.
Texaco 1859 Texamatic Fluid,
Dexron.
Citgo Auto. Trans. Fluid, Dexron.
AMOCO Auto. Trans. Fluid, Dexron.
...or the equivalent to the above.

SPECIFICATION USE DEXRON AUTO-
MATIC TRANSMISSION FLUID or Type
'A', Suffix 'A' ATF (AQA-Armour
Qualified) as available.

LUBRICATION SPECIFICATIONS

LUBRICATION CHART KEY

(D) TRANS. FLUID - continued -
DRIVE UNIT FLUID

FOR ... -COLD STORAGE OPERATION-

FOR ... DRIVE UNIT(S)
NARROW AISLE TRUCKS
POWRWORKERS
ELECTRIC RIDER TRUCKS

SPECIFICATIONS Refer to Specifica-
tions listed under Item "D" on the
previous page.

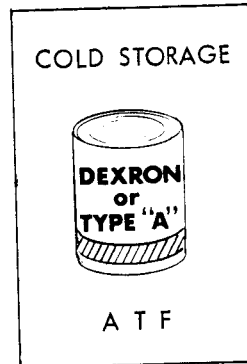

TYPICAL PRODUCT RECOMMENDED BY
MAJOR BRAND OIL SUPPLIERS

Refer to the previous page
under Item "D".

(E) TRANSMISSION FLUID - FORD

FOR ... ALL FORD AUTOMATIC TRANS-
MISSIONS AND CONVERTERS.

SPECIFICATIONS Automatic Trans.,
Fluid, Type "F", which meets
FORD MOTOR COMPANY Specification:

M2C33E (UNDYED) -or-
M2C33F (RED DYED)

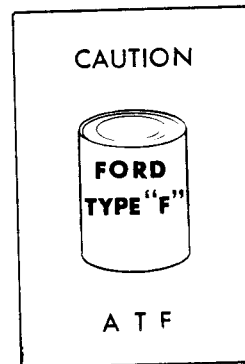

Shell Auto. Trans. Fluid
Donax T-7, Type "F".
Sunoco Auto. Trans. Fluid,
Type "F".
ARCO Auto. Trans. Fluid, Type "F".
Gulf Auto. Trans. Fluid, Type "F".
Citgo Auto. Trans. Fluid, Type "F".
Texaco 1876 Texamatic Fluid,
Type "F".
Mobil Auto. Trans. Fluid 210,
Type "F".
...or the equivalent to the above.

C A U T I O N

DEXRON AND TYPE "A" FLUIDS ARE NOT COMPATIBLE WITH TYPE "F" FLUIDS AND SHOULD NOT BE MIXED. DEXRON FLUID OR TYPE "A" FLUID SHOULD NOT BE USED IN THESE TRANSMISSIONS AND CONVERTERS ... (CTA "E" MODELS) ... TO DO SO WILL RUIN CLUTCH DISC FACINGS.

(F) HYDRAULIC BRAKE FLUID

FOR ... HYDRAULIC BRAKE SYSTEMS
EXCEPT WHEN SPECIFIED
DIFFERENTLY ON THE
LUBRICATION CHART(S)
AND NOT USED FOR COLD
STORAGE.

SPECIFICATION Use only heavy-
duty Hydraulic Brake Fluid which
meets the requirements of SAE J1703b.

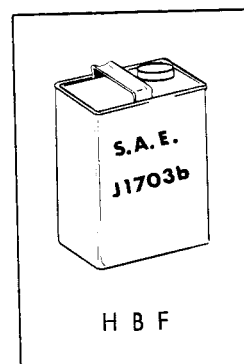

Shell Super Safety or Donax
Brake Fluid.
Gulf Super Heavy Duty Hydraul.
Brake Fluid.
Atlas Heavy Duty Hydraulic Brake
Fluid.
Texaco Super Heavy Duty Hydraulic
Brake Fluid.
Mobil Hydraulic Brake Fluid.
ARCO Heavy Duty Brake Fluid.
Wagner 21B Hydraulic Brake Fluid.
Hollingshead 2665 Heavy Duty
Brake Fluid.
...or the equivalent to the above.



INDUSTRIAL TRUCK DIVISION



LUBRICATION SPECIFICATIONS

LUBRICATION CHART KEY

(F) HYDRAULIC BRAKE FLUID

FOR ... -COLD STORAGE OPERATION-

FOR ... ALL HYDRAULIC BRAKE SYSTEMS EXCEPT WHEN SPECIFIED DIFFERENTLY ON LUBRICATION CHART(S).

SPECIFICATION Use Fluid per CLARK Specification MS-92:

Recommended fluid: 85% by volume, Isopropyl Alcohol: 15% by volume.

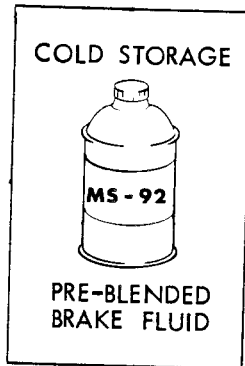

TYPICAL PRODUCT RECOMMENDED BY MAJOR BRAND OIL SUPPLIERS

Extreme Low Temperature Hydraulic Brake Fluid:

Dow Chemical Company
(Pre-Blended
Clark Fluid Number 300)

... Dow Chemical Fluid HD35-4
... Hollingshead Formula 2665

(G) POWER BRAKE VACUUM CYLINDER LUBRICANT

FOR ... BENDIX HYDROVAC UNIT

SPECIFICATION Bendix Vacuum Power Cylinder Oil or approved equivalent.

Apply after installation and periodic maintenance per instruction.

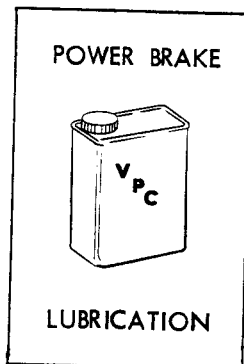

Bendix Vacuum Power Cyl Lubricant
Part No 377299 (2 oz Tube)
Part No 377300 (Quart Can)

Texaco Rabtex
AeroShell Fluid 4
...or the equivalent to the above.

(H) HYDRAULIC FLUID

FOR ... MAIN HYDRAULIC SYSTEMS EXCEPT WHEN SPECIFIED DIFFERENTLY ON THE LUBRICATION CHART(S).

SPECIFICATIONS Use only high quality hydraulic fluid with Zinc Anti-Wear Additive which meets Clark Specification MS-68.

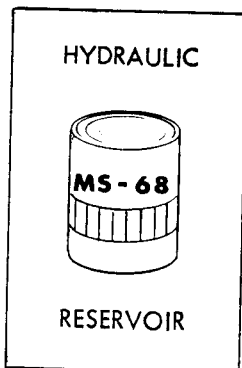

Shell LO Hydrax 127
Sunvis Industrial Oil #816 WRP
Gulf Harmony 43 AW
AMOCO Industrial Oil RL #14A
Citgo Pacemaker XD-15 MS-68 Hydraulic Fluid.
Texaco 729 Rando Oil HD-A
ARCO Duro AW-16 or Duro AWS-150
Chevron EP Hydraulic Oil 9
Molub-Alloy Industrial Hydraulic Oil #601.

...or the equivalent to the above.

(H) -continued-

HYDRAULIC FLUIDFOR ... -COLD STORAGE OPERATION-FOR ... MAIN HYDRAULIC SYSTEMS
EXCEPT WHEN SPECIFIED
DIFFERENTLY ON THE LUBRI-
CATION CHART(S).SPECIFICATIONS Use Hydraulic
Fluid which meets MIL-H-5606A
per CLARK Specification MS-226.A petroleum base hydraulic fluid
with additives to improve viscosity
index, oxidation resistance, and
anti-wear characteristics blended
to form a stable product under
storage and operational conditions
between -65 and +160 deg. F. meet-
ing MIL-H-5606A* per CLARK
Specifications MS-226.*The restrictive
cleanliness specifica-
tions of later revisions
is not required.HYDRAULIC FIRE RESISTANT FLUID

FOR ... SPECIAL APPLICATIONS

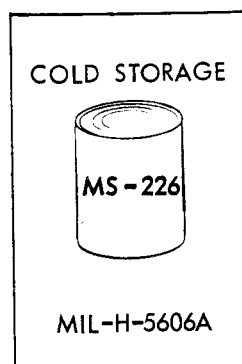
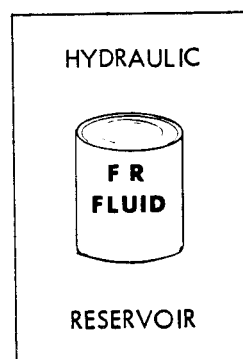
FOR ... MAIN HYDRAULIC SYSTEMS
EXCEPT WHEN SPECIFIED
DIFFERENTLY ON THE LUBRI-
CATION CHART(S).SPECIFICATIONS High quality
Water-Glycol Fire Resistant
Hydraulic Fluid composed of
approximately 42% water and
58% glycol with a nominal
viscosity of 200 SUS at 100F.
Pour point -60 deg. F min.
To contain proper additive
balance to impart optimum
stability, lubricity, wear and
corrosion protection. Approved
by Factory Mutual Insurance
Underwriters.TYPICAL PRODUCT RECOMMENDED BY
MAJOR BRAND OIL SUPPLIERSShell Product #60421
AeroShell Hydraulic Fluid 4
...or the equivalent to the abCitgo Pacemaker Glycol - FR
Fluid, Grade 20.
Houghto-Safe 620
Texaco Hydraulic Safety Fluid
...or the equivalent to the e

NOTE

For data pertaining
to the "testing" of
Water-Glycol ...
refer to the last
page of this KEY.



INDUSTRIAL TRUCK DIVISION



LUBRICATION SPECIFICATIONS

LUBRICATION CHART KEY

(J) DRIVE AXLE GEAR LUBRICANT:

FOR: ... DRIVE AXLES,
HEAVY DUTY DIFFERENTIALS,
PLANETARY WHEEL ENDS.

SPECIFICATIONS: Extreme pressure type gear lubricant with sulfur-chlorine-lead (SCL) 'EP' additive for API GL-4 Service per SAE Report J308a. To meet CLARK Specification MS-8.

Below 0 to -10 de F -- SAE 80
Normal Temperature -- SAE 90
100 deg F and above -- SAE 140

NOTE

SAE 80 and SAE 140 viscosities, when used, should contain like additives as specified by MS-8 (SAE 90). DO NOT ADD (MIX) DIFFERENT TYPES OF LUBRICANT.

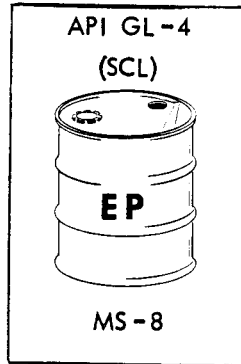

TYPICAL PRODUCT RECOMMENDED BY MAJOR BRAND OIL SUPPLIERS

Shell HDR Gear Oil 90 EP
Shell HDR Gear Oil 140 EP
Chevron RPM Special Gear Lube SCL
Sunoco XD Gear Lubricant
Gulf Hypoid Gear Lubricant A.P.T.
AMOCO Superla Gear Lubricant
Citgo Gear Oil Lead Base
Texaco Gear Lube HD 90
Molub-Alloy Drive Axle Lube #518
Mobilube 46
ELCO Gear Safety 28
...or the equivalent to the above.

(K) GENERAL PURPOSE GREASE:

FOR: ... CLARK AXLE ENDS
WHEEL BEARINGS
STEERING GEARS
JOINTS, LEVERS & BUSHINGS
POWRORKER and NARROW
AISLE TRUCKS - ALL POINTS

SPECIFICATIONS: NLGI #1 per MS-107B

GENERAL PURPOSE GREASE:

FOR: ... STEER AXLE TRUNNION BRGS.
UPRIGHT MAST ROLLERS &
SLIDES.
UNIVERSAL JOINTS.
WATER PUMP BEARINGS.
GENERAL CHASSIS LUBRICATION.

SPECIFICATIONS: NLGI #2 per MS-107C

A multi-purpose grease of refined mineral oil blended with a lithium soap thickener or equal containing anti-wear, anti-rust and anti-oxidants with EP additives.

Clark Specification:
MS-107B - Grade No. 1
MS-107C - Grade No. 2

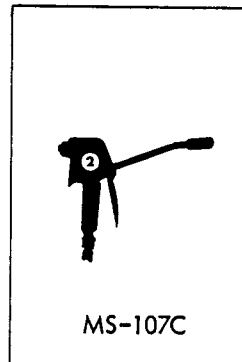
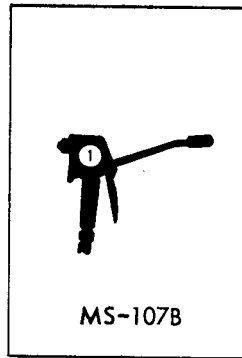

Shell Alvania EP Grease #1 or #2
Sun Prestige 741 EP #1 or #2
Gulfcrown Grease EP #1 or #2
AMOLITH GREASE EP #1 or #2
Citgo HEP Grease #1 or #2 or
Citgo AP Grease.
Texaco Multifak EP #1
or Marfak ALL Purpose #2.
Molub-Alloy General Purpose
Grease #1 or #2.
ARCO Litholine Ind. Grease #2 EP
or Litholine EP #2 Grease.
Mobilgrease 76 or 77
...or the equivalent to the above.

REFER TO THE ABOVE FOR
RECOMMENDED SUPPLIERS.

ADDITIONAL RECOMMENDATIONS

*Chevron BRB-2
*Shell AeroShell Grease 5
*Recommended for Water Pumps
and Universal Joints.

500 HOURS

STEAM CLEAN MACHINE.

CHECK SECURITY OF MOUNTING ON ALL NUTS, BOLTS AND CAPSCREWS.

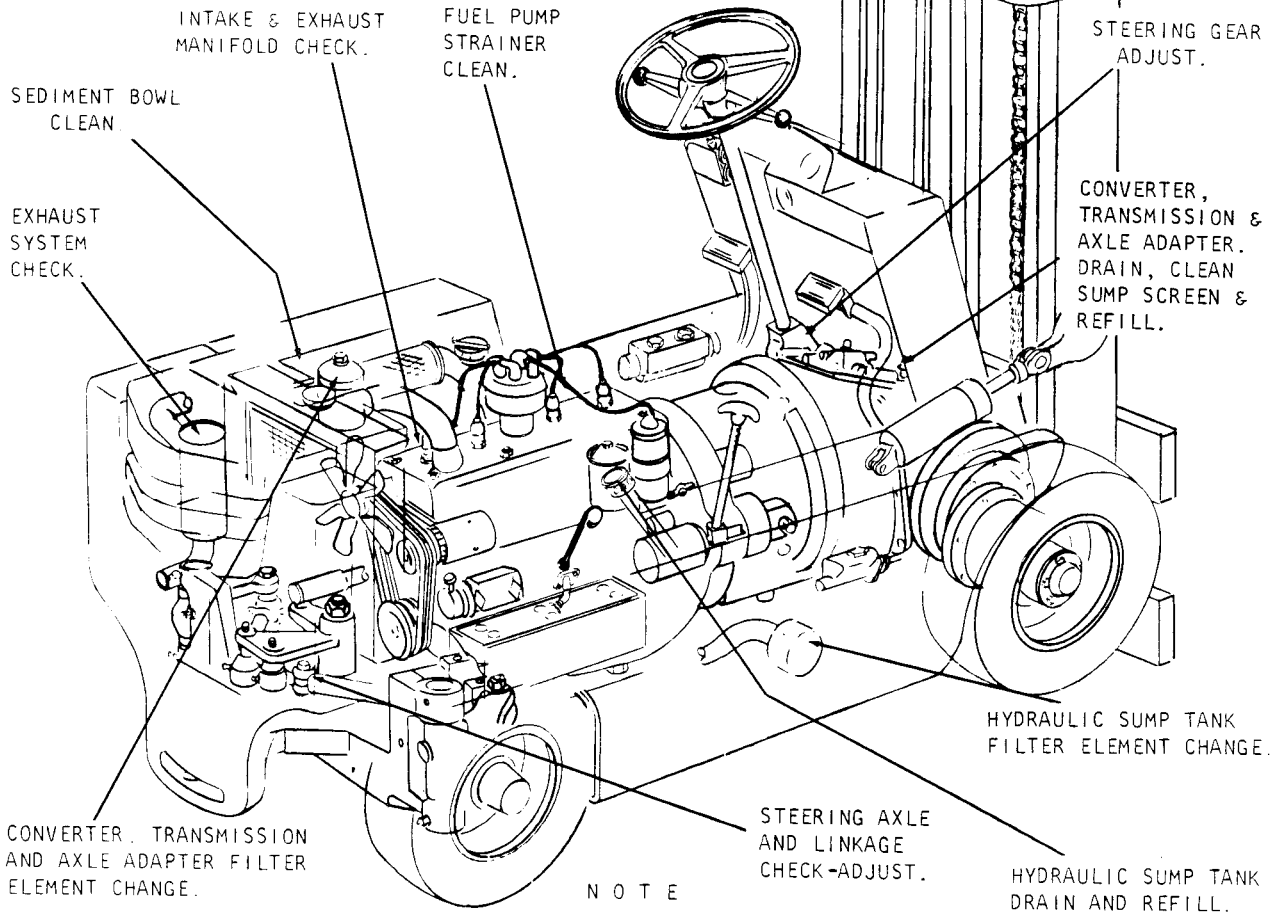

NOTE

IN ADDITION TO THE ABOVE, PERFORM THE 8 HOUR AND 100 HOUR PREVENTIVE MAINTENANCE SERVICES.

FUEL PUMP STRAINER

The fuel filter and sediment bowl should be cleaned every 500 operating hours. Remove and clean sediment bowl. If fuel strainer is dirty, install a new strainer assembly and gasket. Do not reuse old gasket.

FUEL PUMP

To determine if the fuel pump is defective, remove the fuel tank supply line at the pump and blow out line with compressed air to remove any possible obstructions. Reconnect fuel tank line and disconnect pump to carburetor line. Install a fuel pressure gauge, by placing a "T" in the line, and run engine at 1800 R.P.M. with all lines connected. Fuel pump pressure should be between 1 1/2 and 2 1/4 pounds. If the fuel pump pressure is not within this range the pump should be removed for repair or replacement.

C A U T I O N

TO AVOID CREATING A FIRE HAZARD CARE SHOULD BE TAKEN SO THAT GASOLINE IS NOT SPILLED DURING THESE OPERATIONS.

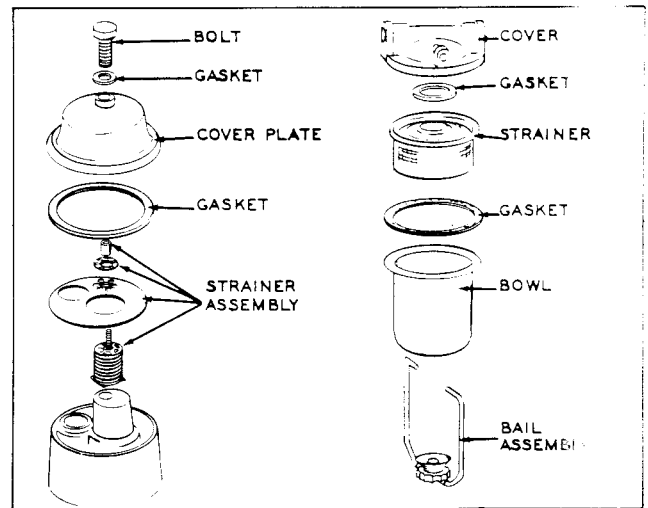

Plate 6638. Fuel Pump & Sediment Bowl

TRANSMISSION FLUID FILTER

The fluid filter element is of the replaceable type. The element should be changed whenever the fluid is drained. To change element, remove filter cover screw and gasket, fluid filter cover, cover spring and cover gasket. Lift out filter element. Drain and thoroughly clean filter case. Install new element. Use new gaskets and install cover spring, filter cover and secure with cover screw.

NOTE

FILTER ELEMENT SHOULD BE REPLACED EACH TIME FLUID IS DRAINED OR AT ANY TIME WHEN A REPAIR TO THE TRANSMISSION IS MADE.

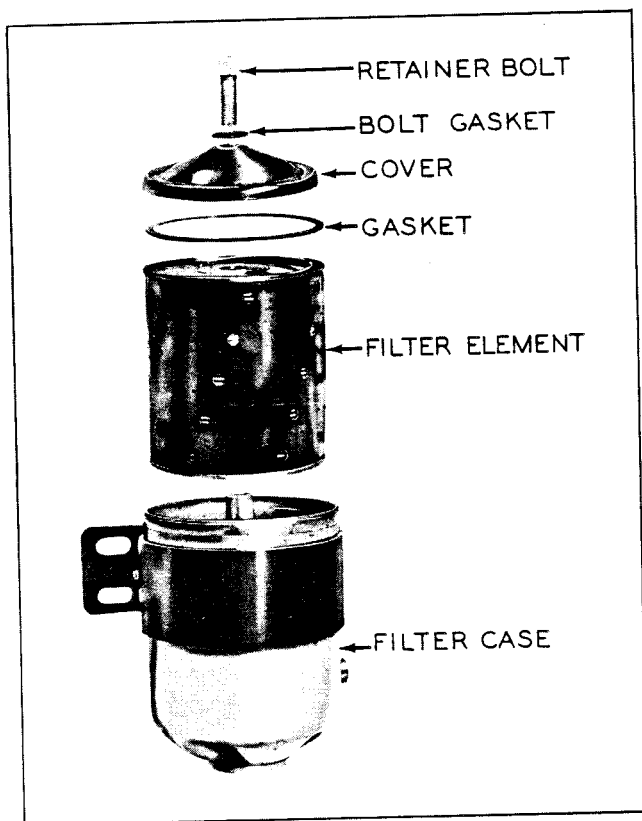

Plate 6635. Transmission Fluid Filter

CONVERTER, AXLE ADAPTER, TRANSMISSION AND TRANSMISSION SUMP SCREEN

1. The Transmission and Axle Adapter have a common lubrication system and should be drained at operating temperature. Remove both plugs to facilitate complete draining. (See Plate 6639).

CAUTION

DO NOT USE FLUSHING OIL OR COMPOUND TO FLUSH SYSTEM.

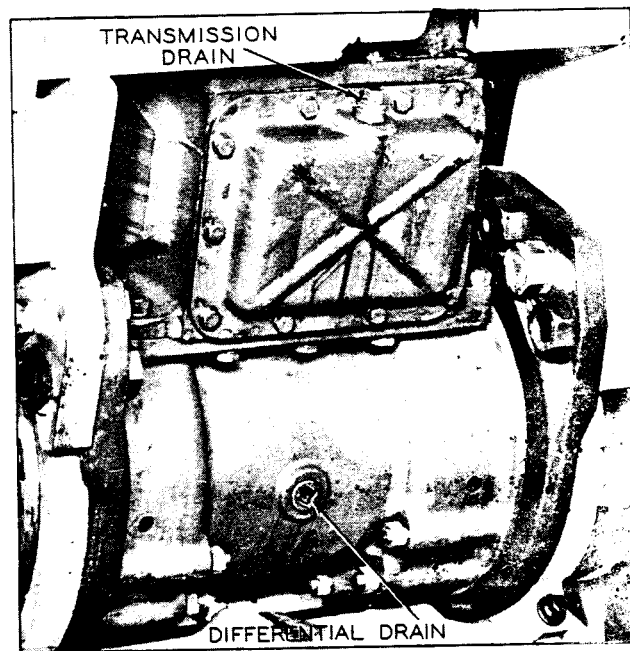

Plate 6639. Drain Differential and Transmission

2. Remove and clean transmission sump screen. Clean old gasket material from mating surfaces. Use a Stoddard type solvent to clean the screen. Blow dry with compressed air -- directing air stream from bottom side thru screen.

3. Coat both sides of new gaskets with number 3 Permatex and install sump and sump cover to bottom of transmission. Tighten capscrews to 20 to 25 foot pounds torque, see Plate 6886 on following page.

4. Replace drain plugs and refill transmission thru the dipstick opening. Use the axle adapter with type "A" Automatic Transmission Fluid (Armour Qualified) Oil, Part Number 879803.

LUBRICATION AND PREVENTIVE MAINTENANCE

5. Operate engine at fast idle for approximately 4 minutes to distribute the lubricant throughout the system.

6. Shut down engine and check fluid level. Add fluid as required to bring the level to the full mark on the dipstick.

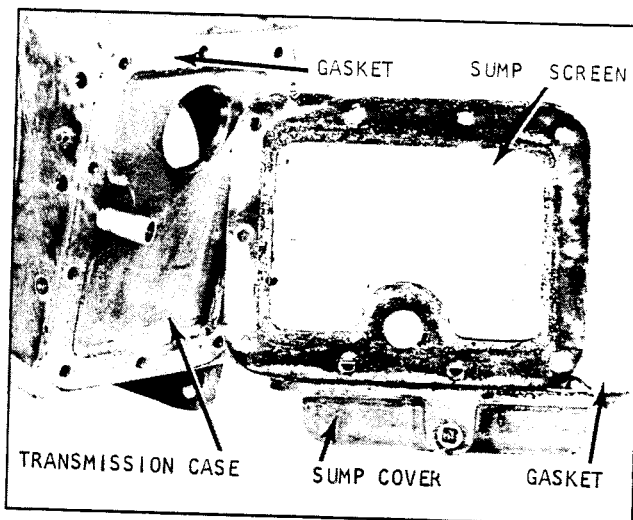

Plate 6886. Transmission Sump Cover and Screen

HYDRAULIC SUMP TANK AND
SUMP OIL FILTER

CAUTION

THE HYDRAULIC SYSTEM MUST BE KEPT CLEAN. IT MAY BE NECESSARY TO DRAIN, CLEAN AND REFILL THE SUMP TANK MORE OFTEN UNDER ADVERSE CONDITIONS. THIS IS BEST DETERMINED BY CHECKING CONDITION OF THE HYDRAULIC FLUID FOR EVIDENCE OF DIRT, SLUDGE OR ANY FOREIGN MATTER AT PERIODIC INTERVALS.

1. Lower upright. Shut engine off.
2. Place a large container underneath the sump tank which is located at the right side of machine.

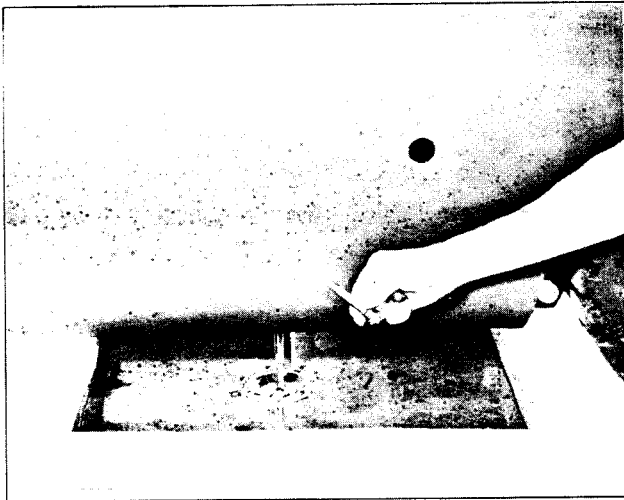

Plate 5359. Draining Sump Tank

3. Remove sump tank drain plug, located at bottom of tank, and allow the fluid to drain. Replace drain plug.

CAUTION

DO NOT START ENGINE WHILE SUMP TANK IS EMPTY AS DAMAGE TO THE HYDRAULIC PUMP WILL RESULT.

4. Remove Filter and Clean Sump Tank:
 - a. Disconnect hose and remove filter retainer bolts.

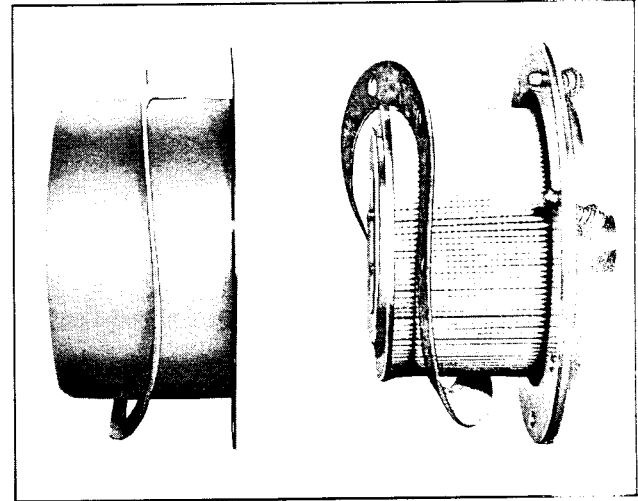

Plate 5274. Sump Tank Oil Filter Components

- b. Pull filter assembly out of sump tank.
- c. Remove any remaining gasket material from mounting flange.
- d. Before installing a new filter and gasket, be sure sump tank is absolutely clean. Flush sump tank with two quarts of clean hydraulic oil.

NOTE

THE FILTER ATTACHING BOLTS SHOULD BE TIGHTENED TO 40 TO 50 INCH POUNDS. IF THIS TORQUE IS EXCEEDED, DISTORTION MAY OCCUR, CAUSING LEAKAGE.

- f. Install hose and tighten hose connections.

5. Fill sump tank with MS 68 Hydraulic fluid until level reaches the bottom of the fill pipe.

CAUTION

START ENGINE AND OPERATE HYDRAULIC CONTROLS SEVERAL TIMES, CHECK OIL FILTER FOR LEAKS, RECHECK OIL LEVEL AND FILL TO BOTTOM OF FILL PIPE IF NECESSARY.

STEERING GEAR

Steering gear adjustments must be made in the following manner (see Plates 6636 and 6637).

Always check worm bearing thrust adjustment, and adjust if necessary, before making sector gear lash adjustment.

Before making above adjustments, the following preliminary operations are necessary.

1. Disconnect steering drag link from pitman arm. Note relative position of drag link parts when disconnecting link so the parts may be re-assembled correctly.
2. Check lubricant level in steering gear housing. If low, add enough lubricant to bring level up to filler plug hole. (Use NLGI #1 Amolith grease EP #1 or its equivalent).
3. Tighten steering gear housing to frame side member bolts, see Plate 6636.
4. Determine straight-ahead position of steering mechanism by turning steering wheel to extreme right.

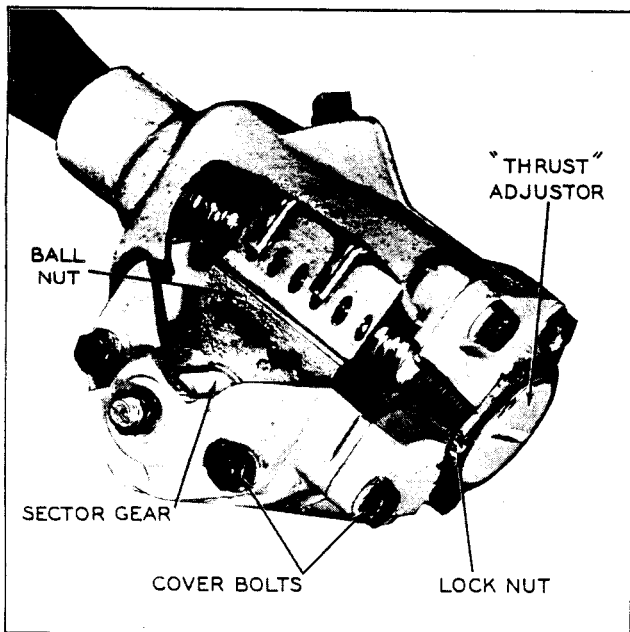

Plate 6636. Steering Gear Thrust Adjustment (Worm Bearings)

CAUTION

APPROACH EXTREME ENDS CAUTIOUSLY; WORM BALL NUT MUST NOT STRIKE ENDS WITH ANY DEGREE OF FORCE.

Then turn to extreme left, counting the exact number of turns from right to left end. Turn wheel back one-half number of wheel turns. Mark wheel with respect to steering column so center position may readily be found during adjustment procedures.

Worm Bearing THRUST Adjustment: Refer to Plate 6636 and proceed as follows:

1. Check tightness of cover bolts, see Plate 6636. Loosen lock nut and turn lash adjuster screw (Plate 6637) counterclockwise a few turns to provide clearance between sector gear and worm ball nut.

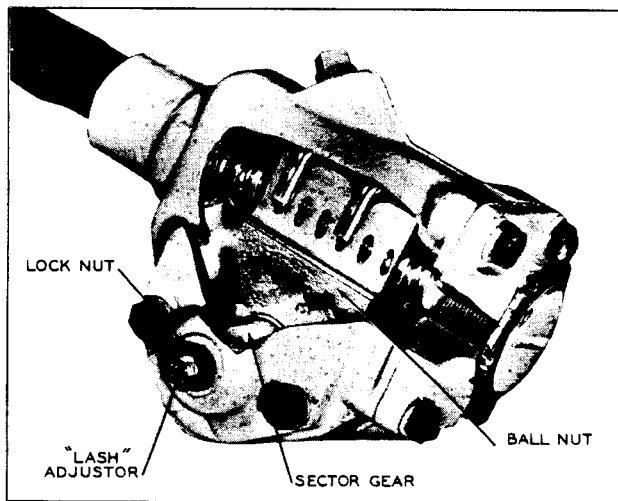

Plate 6637. Steering Gear Lash Adjustment (Sector Gear)

2. Turn steering wheel GENTLY to one extreme end. Turn wheel back one full turn. With spring scale on spoke of wheel, measure pull required to KEEP WHEEL MOVING. Pull on scale should be made at right angles to wheel spoke. If pull is within 1 1/2 to 2 pounds, proceed to lash adjustment in the following paragraphs. If pull is not within 1 1/2 to 2 pounds, adjust worm bearings. The pitman shaft adjustment must be made if worm bearing check is accomplished, or if the worm bearings are adjusted.

3. If it is necessary to adjust the worm bearings, loosen lock nut and then turn worm bearing adjuster nut clockwise until all end play is removed, see Plate 6636. Using



INDUSTRIAL TRUCK DIVISION



LUBRICATION AND PREVENTIVE MAINTENANCE

spring scale, as directed in Step 2, check pull and readjust as necessary; then tighten lock nut securely.

Sector Gear Lash Adjustment: Refer to Plate 6637 and proceed as follows:

1. Steering Gear Mechanism must be in straight ahead position as previously explained.
2. Turn lash adjuster screw clockwise to remove all lash between gear teeth. Tighten adjuster screw lock nut. Position spring scale on steering wheel so pull may be made at right angles to wheel spoke.
3. Measure pull while wheel is TURNED THROUGH CENTER POSITION. Readjust if reading is not within 2 1/2 to 3 pounds.
4. Tighten adjuster screw lock nut, check pull again.
5. After adjustments are made, install drag link on pitman arm.

N O T E

If steering linkage adjustment is necessary do not install drag link to pitman arm.

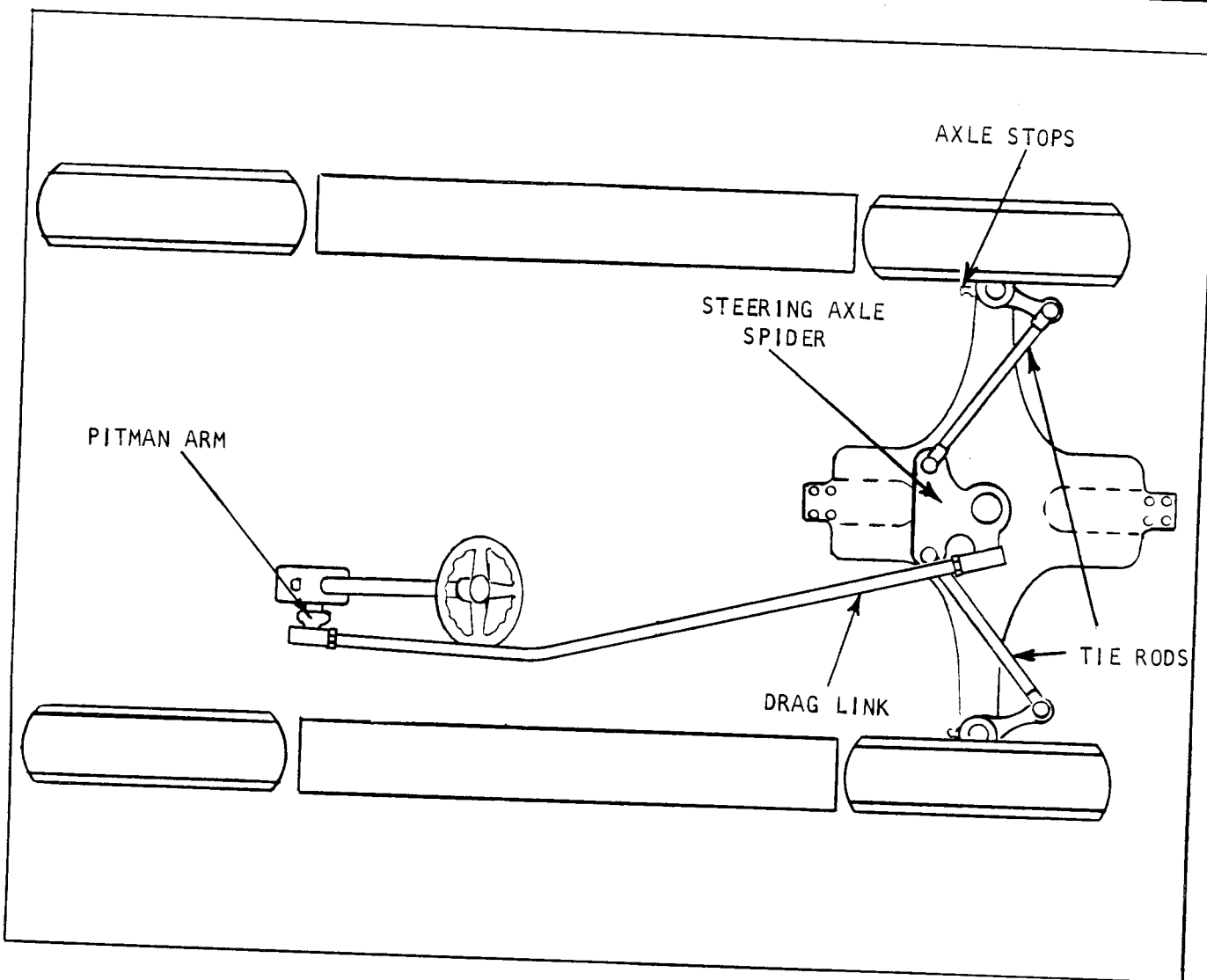

Plate 7419. Steering Linkage

STEERING AXLE AND LINKAGE ADJUSTMENTS

1. Raise the steering wheels far enough to clear the floor and place heavy blocking under the machine frame so it cannot accidentally become lowered during adjustments.

2. The steering wheels should track square with the drive wheels with no toe-in or toe-out. If adjustment is necessary loosen the lock nuts at the tie rod ends and turn each tie rod in a manner so they will be the same length when the correct adjustment is obtained. Tighten tie rod lock nuts to secure this adjustment.

3. Disconnect the drag link socket from the steering pitman arm noting the relative position of the socket parts so they may be re-installed correctly after

checking wheels for correct turning geometry.

4. Check wheels for correct turning geometry by turning the wheels all the way for a left turn - this should allow the left wheel to attain an angle of 80 degrees to the frame. If an adjustment is necessary, the axle stop on the left side should be turned in or out whichever is necessary to achieve the correct angle. Repeat this procedure in a right turn with the opposite wheel and adjust the right axle stop as required.

5. Turn Steering wheels to straight ahead position.

6. Determine center position of steering gear. (Refer to Steering Gear adjustments for correct procedure).



INDUSTRIAL TRUCK DIVISION



LUBRICATION AND PREVENTIVE MAINTENANCE

7. Adjust drag link socket so that the grease fitting lines up with the centerline of the pitman arm ball stud and secure with lock nut and cotter pin.

8. Turn the handwheel until wheels are in straight ahead position. Remove handwheel and replace on steering column with the center spoke aligned minus or plus 10 degrees with the center line of the machine, the center spoke pointing back.

NOTE

CHECK STEERING GEAR SUPPORT BOLTS FOR SECURITY OF MOUNTING. TIGHTEN MOUNTING BOLTS AND CLAMP BOLTS TO 90 FOOT POUNDS TORQUE.

9. Remove blocking from under front and lower machine to the floor.

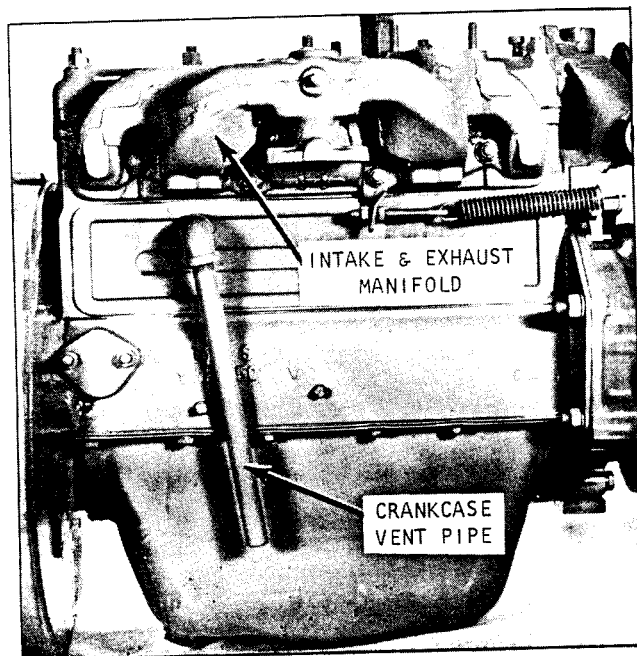

Plate 7470. Intake and Exhaust Manifolds

INTAKE AND EXHAUST MANIFOLDS

1. Inspect gaskets for leaks and inspect security of manifold nuts.
2. Inspect exhaust pipe and muffler for damage, leakage and security of mounting.

NUTS, BOLTS AND CAP SCREWS. Check security of mounting, tighten as required.

1000 HOURS

ENGINE TUNE UP

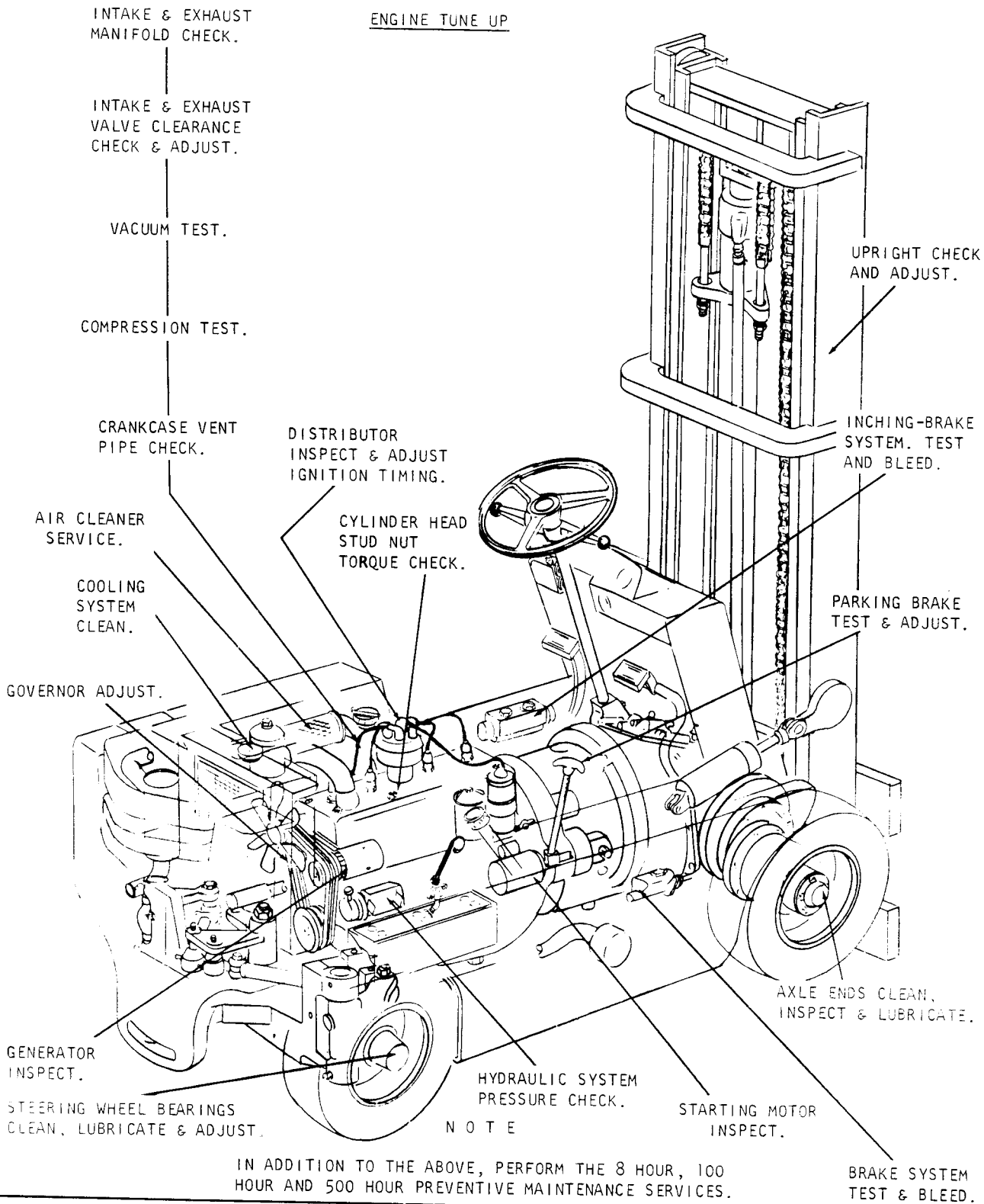

Plate 7995. Lubrication and Preventive Maintenance Illustration

ENGINE TUNE-UP

Engine tune-up is the orderly and systematic process of checking the engine and accessory equipment to maintain or restore satisfactory engine performance. Engine tune-up must be accomplished semi-annually and more frequently if engine performance indicates the need for these services. Perform engine tune-up as follows:

1. AIR CLEANER. Be sure air cleaner has received proper service. Air cleaner must be installed before making engine tune-up.

2. FUEL PUMP. Be sure the fuel pump bowl and strainer has been properly serviced and the fuel pump is operating satisfactorily.

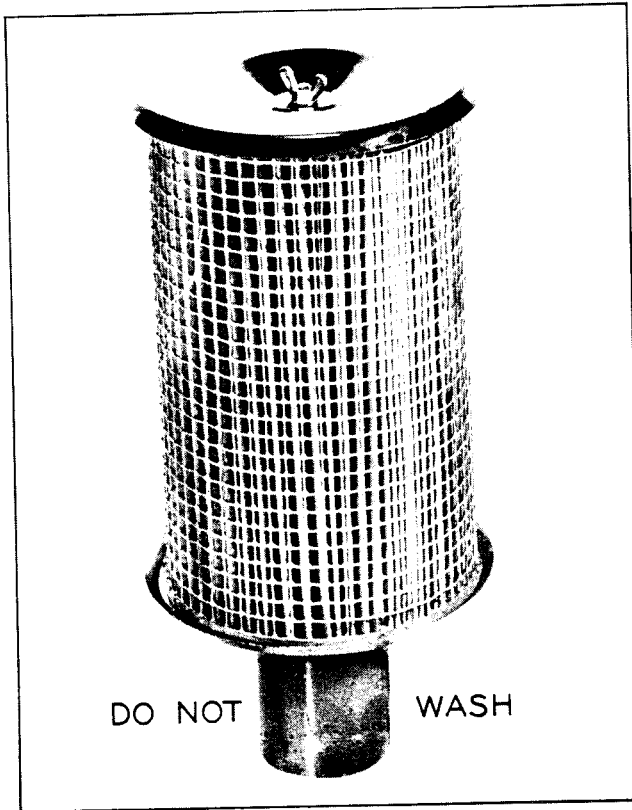

Plate 5697. Typical Air Cleaner

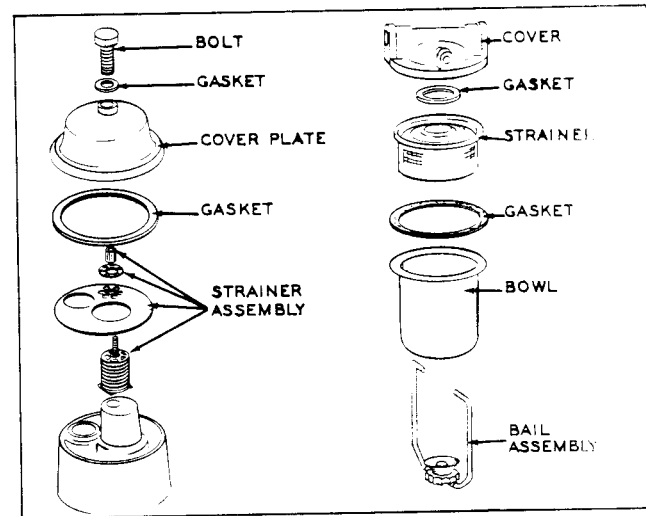

Plate 6638. Fuel Pump Strainer & Sediment Bowl

3. CYLINDER HEAD STUD NUTS. Check all stud nuts for correct torque, refer to specifications. Check cylinder head gasket for leaks.

CAUTION

THE SEQUENCE SHOWN ON PLATE 6281 MUST BE FOLLOWED. ALL CYLINDER HEAD CAP SCREWS OR NUTS MUST BE TIGHTENED EVENLY AND TORQUED IN ACCORDANCE WITH LIMITS LISTED IN SPECIFICATIONS.

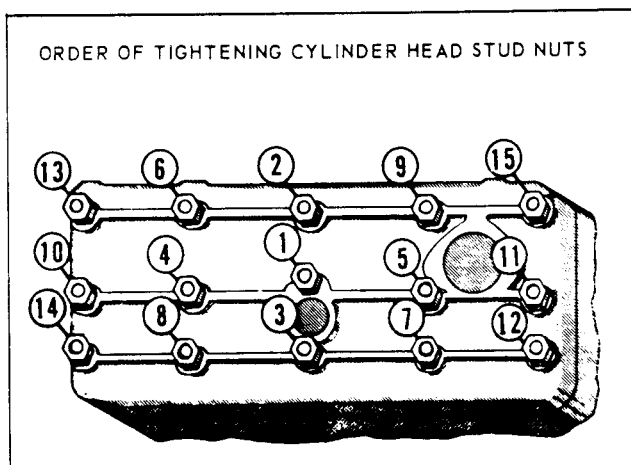

Plate 6281. Cylinder Head Stud Nut Tightening Sequence

4. INTAKE AND EXHAUST MANIFOLDS. Inspect for gasket leaks and security of mounting.

5. CRANKCASE VENTILATION. The crankcase vent pipe allows clean air to pass through the crankcase to help carry off corrosive gases (which are the by-products of combustion) that leak by the pistons and valve stems.

Check crankcase ventilation pipe for damage or obstructions. The pipe must be open to provide proper ventilation. Clean, repair, or replace as required, see Plate 7470.

6. INTAKE AND EXHAUST VALVE CLEARANCE ADJUSTMENTS. (PREFERRED METHOD).

a. Remove valve chamber cover mounting screws, and the valve chamber cover gasket.

b. With engine running at idling speed and at normal operating temperature, adjust intake valves as follows:

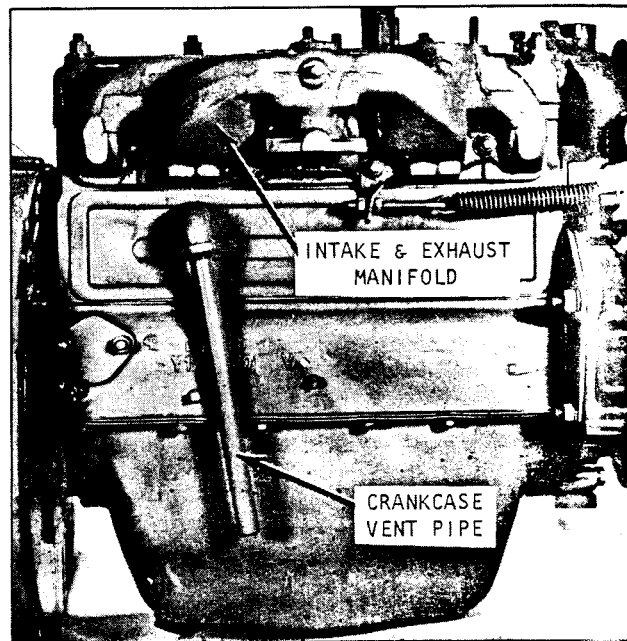

Plate 7470. Crankcase Vent Pipe

c. Check for proper 0.012 inch clearance by alternately passing a 0.011 inch and a 0.013 inch flat feeler gauge between head of adjusting screw and valve stem, see Plate 3223 on following page.

d. If a 0.011 inch feeler gauge moves freely back and forth in gap valve is not being lifted and a 0.013 inch feeler gauge binds, at all times, clearance requires no adjustment.

e. If a 0.011 inch feeler gauge is gripped at all times, the clearance is insufficient.

f. Hold valve lifter with an open end wrench while using a second wrench to turn adjusting screw 1/4 to 1/2 turn clockwise. Repeat clearance check and adjustment, until proper clearance is obtained. The adjustable type valve lifters have self-locking adjusting screws that require no lock nuts.

g. If 0.013 inch feeler moves freely when valve is not being lifted, the clearance is too great. Hold valve lifter with an open end wrench while using a second wrench to turn valve lifter adjusting screw counterclockwise 1/4 to 1/2 turn. Repeat clearance check and adjustment until proper clearance is obtained.

h. Repeat clearance check and adjustment on remaining intake valves.

i. With engine running at slow idle and at normal operating temperature, adjust exhaust valves as follows:

j. Check for proper 0.012 inch clearance by alternately passing a 0.011 inch and a 0.013 inch flat feeler gauge between head of adjusting screw and valve stem, see Plate 3223.

k. If a 0.011 inch feeler gauge is gripped at all times, the clearance is insufficient. If a 0.013 inch feeler gauge moves freely when valve is not being lifted, the clearance is too great.

m. Turn adjusting screw in the direction necessary so that a 0.011 inch feeler gauge moves freely back and forth in gap and a 0.013 inch feeler is gripped at all times.

n. After adjustment is complete on all exhaust valves, install valve chamber cover using new cover gasket and replace cover retainment screws.

N O T E

DO NOT REUSE OLD GASKETS. THEY DO NOT AFFORD A POSITIVE SEAL.

o. Check valve chamber cover gasket for leaks.

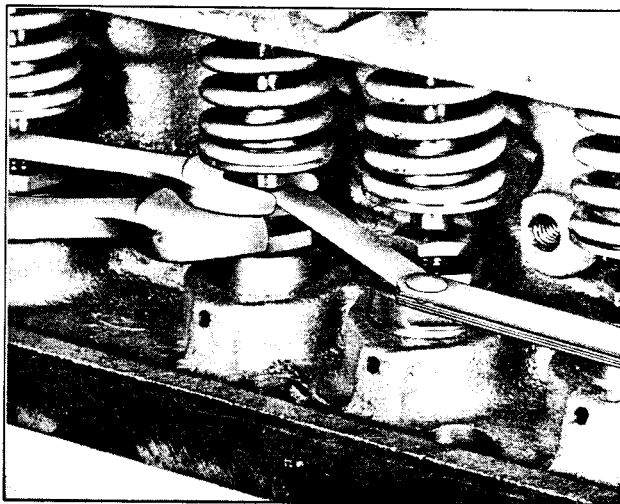

Plate 3223. Adjusting Valve Clearance

6A. COLD SETTING. (ALTERNATE METHOD)

To adjust valve clearance when engine is at room temperature and not running, proceed in the following manner:

a. Remove distributor cap.

b. Crank engine until distributor rotor points to No. 1 cylinder position with the breaker points open. In this position the No. 1 piston is at the top of its compression stroke with both lifters on the base circle of the cam and both valves can be adjusted.

c. Adjust the valve clearance to 0.014 inch on the intake and 0.014 inch on the exhaust. The exhaust (E) and intake (I) valve arrangement on the four cylinder engine is: E-I-I-E-E-I-I-E.

d. The other valves may be adjusted by setting the engine with the distributor rotor pointing to the rest of the cylinder positions in the sequence of the firing order which is: 1-3-4-2.

7. COMPRESSION TEST

a. Test battery for full charge (specific gravity 1.280 temperature of 24°C (75°F)). If battery is not fully charged, replace with fully charged battery.

b. Start engine and allow it to warm up until normal operating temperature is reached.

c. Turn off ignition.

d. Remove spark plug cables from spark plugs and remove spark plugs from cylinder head. Examine spark plugs for carbon deposits, defective insulation and general serviceability. All carbon or lead deposits must be removed from the insulation shell and electrodes. This can be done on a sand blast cleaner. Carbon deposits should be removed from the plug threads with a stiff brush. After cleaning, inspect plugs carefully for cracked or broken insulator, badly pitted electrodes or other signs of failure.

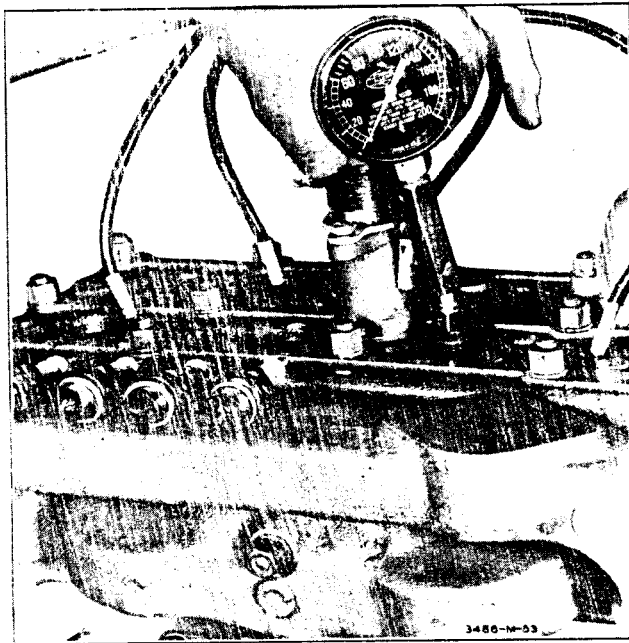

Plate 3486. Compression Test

e. With all plugs removed, install compression gauge in front spark plug port. Operate starting motor until maximum reading on gauge is obtained, see Plate 3486. Record gauge reading. Repeat this operation on each remaining cylinder.

f. If readings are reasonably high (110 to 120) pounds and the readings do not vary more than about 10 pounds between cylinders, compression may be considered normal. Excessively low readings or readings that vary more than 10 pounds between cylinders indicate internal trouble to be corrected after further examination and testing.

g. Set the spark plug gap as specified, by bending side electrode only. The gap should be checked with a wire feeler gauge rather than a flat type gauge as it is better suited for this purpose.

h. Spark Plug Specifications:

Standard Type - .025" Gap
Resistor Type - .035" Gap

i. Replace spark plugs using new sockets. Always replace spark plug gasket whenever a spark plug is removed from the engine. Before installing plugs, be sure that the spark plug seat in the cylinder head is clean and free from obstructions. The spark plug should be screwed into cylinder head (using a socket of proper size) sufficiently tight to fully compress the gasket. This is most important as a large percentage of troubles due to overheated spark plugs are caused by plugs being too loose in the cylinder head. Conversely, excessive tightening may change the gap between the electrodes or crack the insulator.

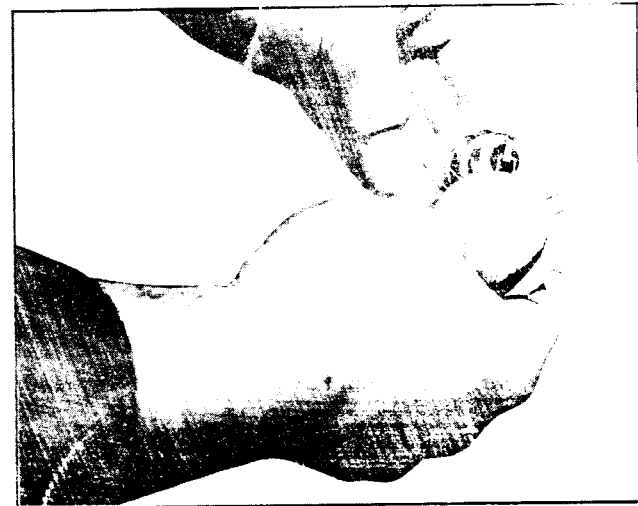

Plate 3278. Check Spark Plug Gap

8. DISTRIBUTOR

Inspection: Remove distributor cap (without removing wires). Wipe cap with a clean cloth. Examine rotor and cap for chips, cracks, corroded terminals, carbon runners (paths which will allow high-tension leakage to ground) or if the vertical faces of the inserts are burned -- install a new cap and rotor, as this is due to the rotor being too short.

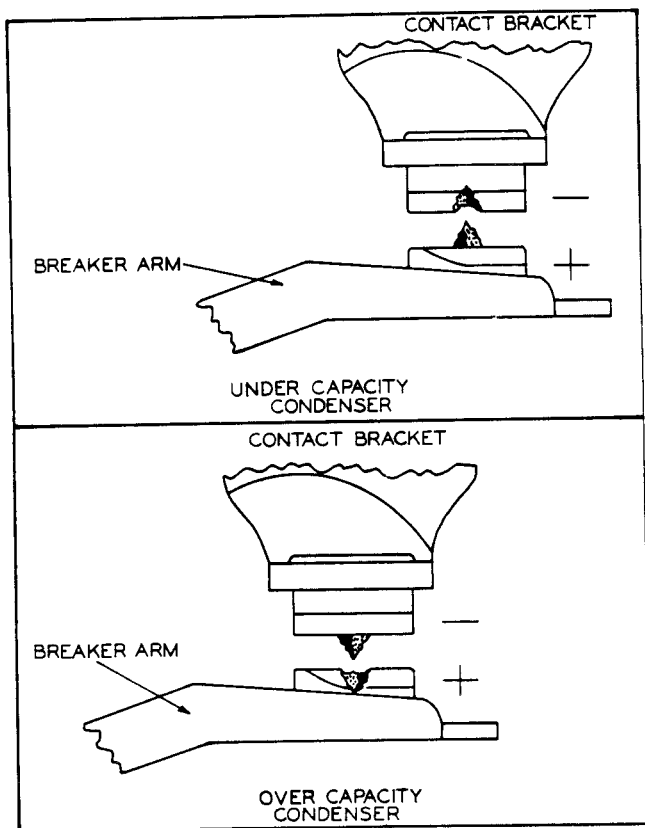

Plate 5933. Breaker Points

Check the centrifugal advance mechanism for "freeness" by turning the breaker cam in the direction of rotation and then releasing it. The advance springs should return the cam to its original position without sticking.

Inspect breaker points. If points are pitted, burned or worn to an unserviceable condition, install a new set of points.

The normal color of contact points should be a light gray. If the contact point surfaces are black, it is usually caused by oil vapor, or grease from the cam. If they are blue, the cause is usually excessive heating due to improper

alignment, high resistance or open distributor circuit.

Badly pitted points may be caused by a defective or improper condenser capacity.

If the condenser capacity is too high, the crater (depression) will form in the positive contact. If the condenser capacity is too low, the crater will form in the negative contact, see Plate 5933.

For a temporary repair, dress the contact points with a few EVEN strokes using a clean fine-cut contact file. NOT ATTEMPT TO REMOVE ALL ROUGHNESS. DRESS THE POINT SURFACES DOWN SMOOTH. See Plate 7475.

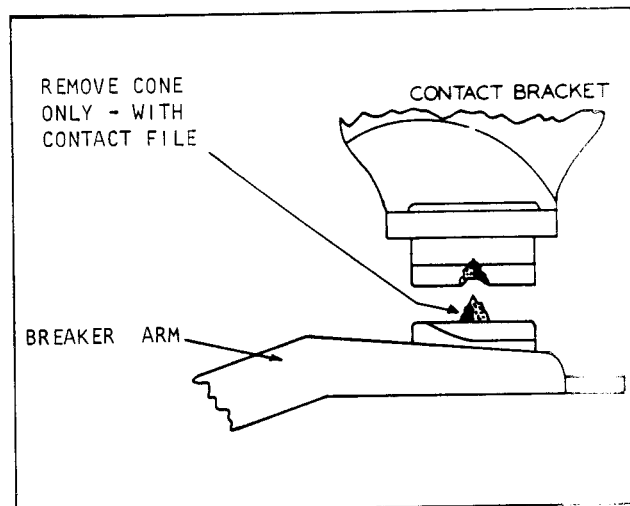
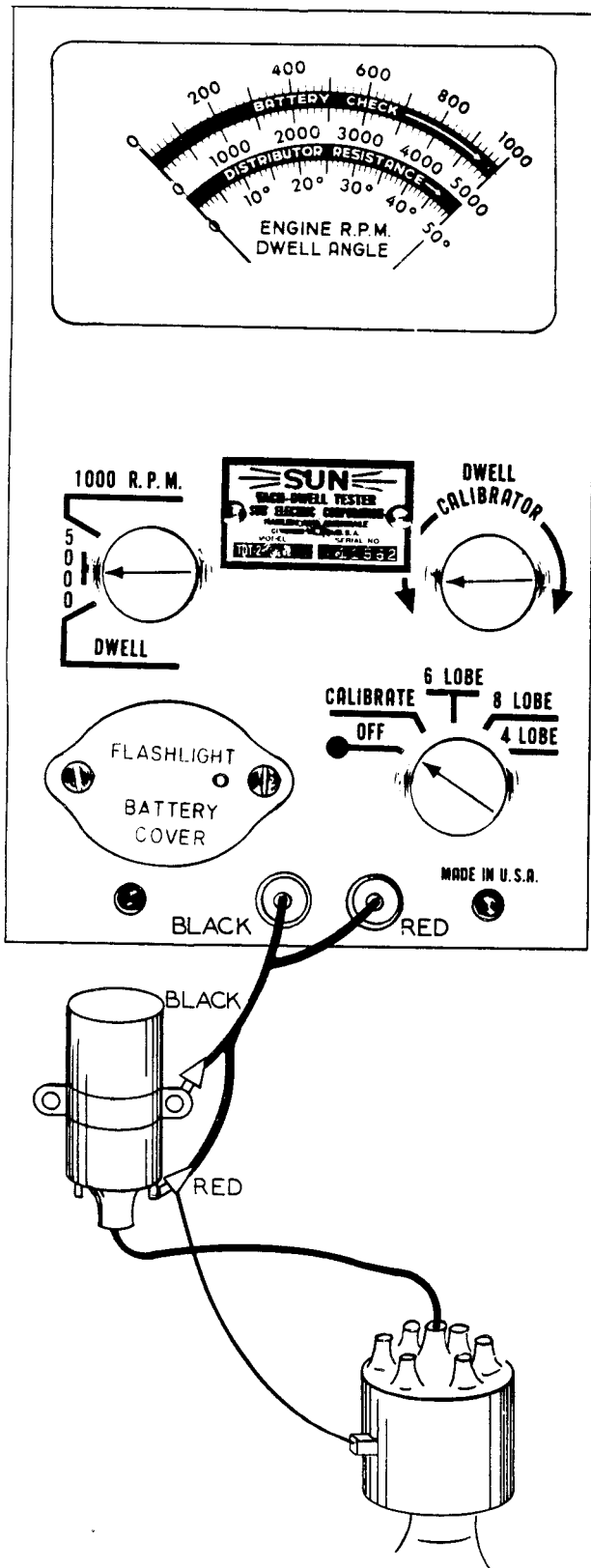

Plate 7475. File Contact Points

C A U T I O N

NEVER USE EMERY CLOTH OR SANDPAPER TO CLEAN POINTS AS PARTICLES WILL EMBED IN THE POINTS AND CAUSE ARCING AND RAPID BURNING.



MEASURING ENGINE SPEED

1. Connect the test leads as shown.
2. Turn switch to the LOBE position corresponding to the number of cylinders.
3. Turn the other switch to the 1000 rpm position for all idle and low speed testing. Use the 5000 rpm position for all speeds over 1000 rpm.

DISTRIBUTOR RESISTANCE TEST

1. With test leads disconnected, turn switches to DWELL and CALIBRATE positions and adjust dwell calibrator until meter reads on the SET LINE.
2. Connect test leads as shown.
3. Turn ignition switch ON with engine stopped. If distributor resistance is not excessive, meter will read in the black bar marked DISTRIBUTOR RESISTANCE.

If meter does read within black bar, readjust dwell calibrator until meter again reads on the SET LINE before making the following tests.

If meter does not read within black bar, excessive resistance is indicated. To locate excessive resistance, trace the primary circuit through the distributor with the red test lead until point of high resistance is located. Excessive resistance must be eliminated and the dwell calibrator adjusted until the meter again reads on the SET LINE before proceeding with the following tests.

DWELL AND DWELL VARIATION TESTS

1. Turn switch to the proper LOBE position.
2. Operate engine at idle speed and note reading on dwell scale of meter. Refer to specifications for proper dwell.
3. Turn tachometer switch to the 5000 rpm position and increase speed to 1500 rpm.
4. Turn switch back to the DWELL position and again note dwell reading. Slowly reduce speed to idle while watching meter. Dwell should not change more than 3 degrees in either case.

Contact Point Adjustment: The point opening of new points can be checked with a wire feeler gauge, but the use of a feeler gauge on older, rough points is not recommended, since accurate gauging cannot be done on such points. The gauge measures between high spots on the points instead of the true point opening. Point opening of used points can be checked with a Dwell Angle Meter. A meter of this type indicates the cam or contact angle. This angle is the number of degrees that the breaker cam rotates from the time the points close until they open again. The cam angle increases as the point opening decreases and it is reduced as the point opening is increased. Manufacturers of this type equipment furnish complete instructions as to their use.

N O T E

REFER TO SPECIFICATIONS FOR DWELL ANGLE AND CONTACT POINT OPENING.

To check point opening with a feeler gauge, insert a wire feeler gauge of proper size between the contact points. MAKE CERTAIN THAT THE BUMPER BLOCK ON THE MOVABLE CONTACT IS AT THE HIGH POINT ON THE CAM. If adjustment is necessary, loosen the lock screw, and insert a screwdriver of the proper size in the adjustment slot and move the stationary arm until the correct clearance is obtained. Tighten locking screw and recheck point gap. See Plate 7457.

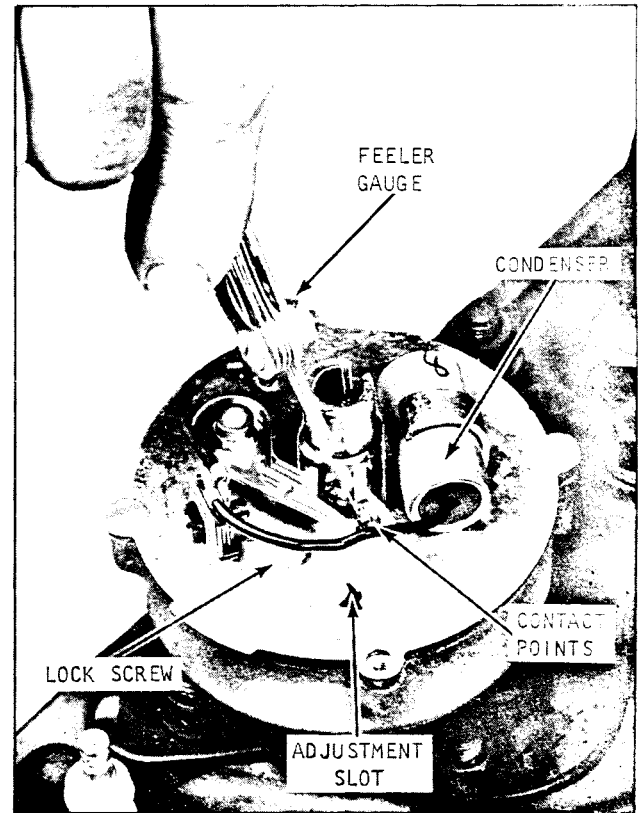

Plate 7457. Contact Point Adjustment

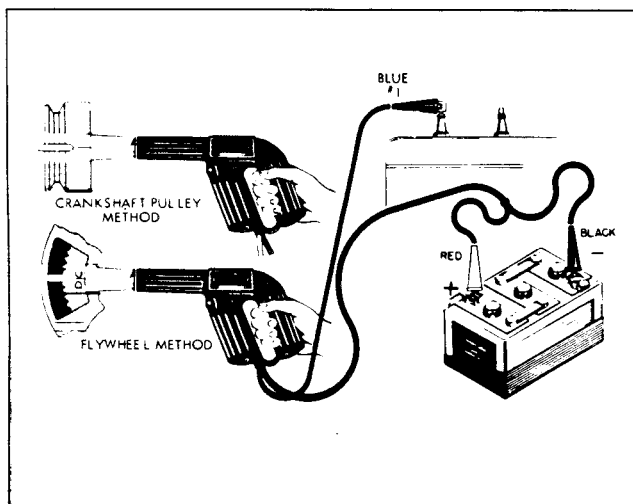

Plate 7818. Timing Light Hookup

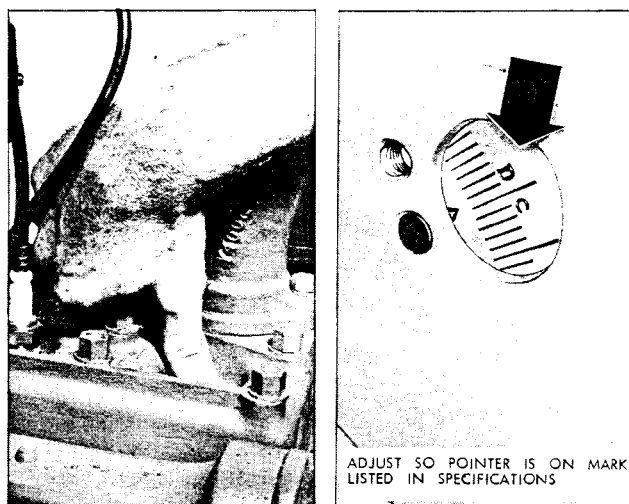

Plate 7861. Ignition Timing

9. IGNITION TIMING

There are two methods of checking ignition timing --- with or without a timing light. The PREFERRED METHOD is to use a timing light in following sequence:

Paint a line on the flywheel (or in some cases, on the front pulley) so the correct timing mark will be more legible under the timing light.

- a. Clip blue secondary lead of light to the #1 spark plug -- leave spark plug wire on plug.
- b. Connect primary positive lead (red) to positive terminal of battery.
- c. Connect primary negative lead (black) to negative battery terminal.
- d. Start engine and run a 400 RPM or below so the automatic advance of the distributor is completely retarded. THIS IS VERY IMPORTANT TO OBTAIN CORRECT TIMING.

N O T E

The initial advance RPM range is 430-580. Distributor advance at 600 engine RPM should be 1° to 5°.

e. Direct timing light on the pulley (or flywheel through opening in bell housing) and note timing marks as light flashes. The light should flash on the timing mark that is listed in specifications.

f. To advance timing, turn distributor body clockwise. To retard timing, turn distributor body counterclockwise.

g. When timing is correct, tighten distributor clamp screw securely. Then recheck timing again with light.

ALTERNATE TIMING METHOD

- a. Remove #1 Spark Plug -- put your thumb over the spark plug hole and crank engine by hand until air is exhausting.
- b. Continue to slowly crank engine until the mark listed in specifications lines up with the pointer in bell housing.
- c. Loosen the distributor clamp bolt and rotate the distributor body until the contact points just start to open. (This may be more accurately checked by means of a test lamp connected between the distributor primary lead and the negative terminal of the battery -- when the points are closed the light will be ON and as soon as the points break the light will go OFF.)
- d. Tighten distributor mounting bolts.

10. VACUUM TEST

Before making vacuum test, make certain cylinder head is securely tightened and that cylinder head gasket is not leaking. Air cleaner must be installed and must be clean to perform vacuum test. Manifold stud nuts must be tight and there must not be any leakage at gasket.

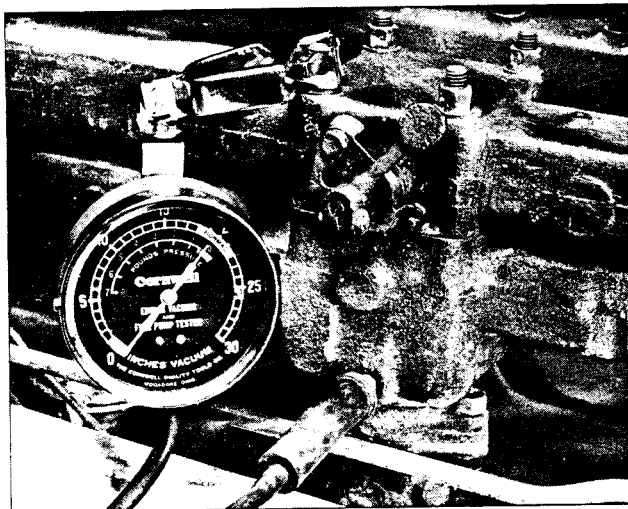

Plate 6643. Vacuum Test

(a) Remove plug at intake manifold and install vacuum gauge, see Plate 6443. Using the tachometer, set the engine idle speed at 450 to 500 RPM.

Idle Speed Adjustment: A stop screw controls action of the throttle valve. Turn screw clockwise for faster idle speed, or counterclockwise for slower idle speed. This adjustment should be made with a tachometer. Idling speed should be set for 450 to 500 revolutions per minute. Reset idle mixture screw if necessary, after throttle adjustment has been made, see Plate 6889.

(b) Check the vacuum gauge. A steady reading from 18" to 22" of mercury is a normal reading, indicating that valve and spark timing, valve seating, and piston ring sealing are all satisfactory.

(c) A steady but below normal reading indicates a condition common to all cylinders such as a leak at the carburetor gasket, late ignition or valve timing, or uniform piston ring and bore wear.

(d) A slowly fluctuating or drifting reading indicates that the fuel idle mixture is incorrect. Look for the cause in the fuel system.



Plate 6889. Idle Speed Adjustment

(e) A rhythmic pulsating reading is caused by a condition affecting one or more cylinders, but not all, and indicates leaky valve, gasket blow-by, restricted intake port, or an electrical miss.

(f) An intermittent pulsating reading is caused by an occasional malfunction, such as sticking valve (all valves may be erratic in operation if the valve springs are weak), electrical miss caused by insufficient distributor point tension or low coil voltage coupled with inconsistent spark plug gaps or fouled plugs, or dirt in the fuel system finding its way into passages of critical size or valve seats in the carburetor.

(g) A normal reading that quickly falls off (with engine running at approx. 1860 RPM) indicates exhaust back pressure caused by a restriction in the exhaust system.

(h) Make indicated corrections to bring vacuum to 18" to 22" of mercury normal reading.

Idle Fuel Adjustment: The carburetor is controlled by the idle adjustment screw that regulates the fuel-air mixture, see Plate 6889. Turning the screw clockwise, towards the seat, cuts off air increasing the suction on the idle jet and making the mixture richer. Turning the idle adjusting screw counterclockwise, or away from seat, allows more air to be mixed with the fuel making a leaner mixture for idling.

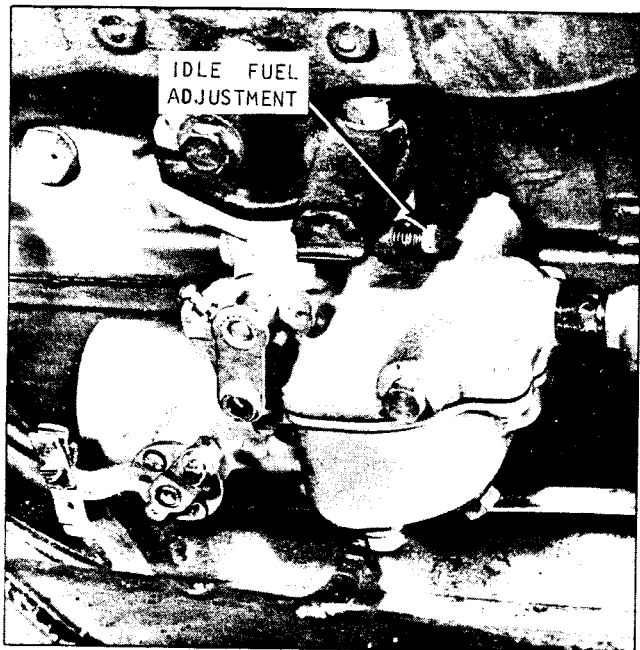

Plate 6888. Idle Fuel Adjustment

Turn the screw until highest vacuum reading is obtained. If vacuum gauge needle cannot be held steady after these adjustments have been made, report condition to designated person in authority.

If a gauge is not used, set the screw to a range at which engine idles its smoothest.

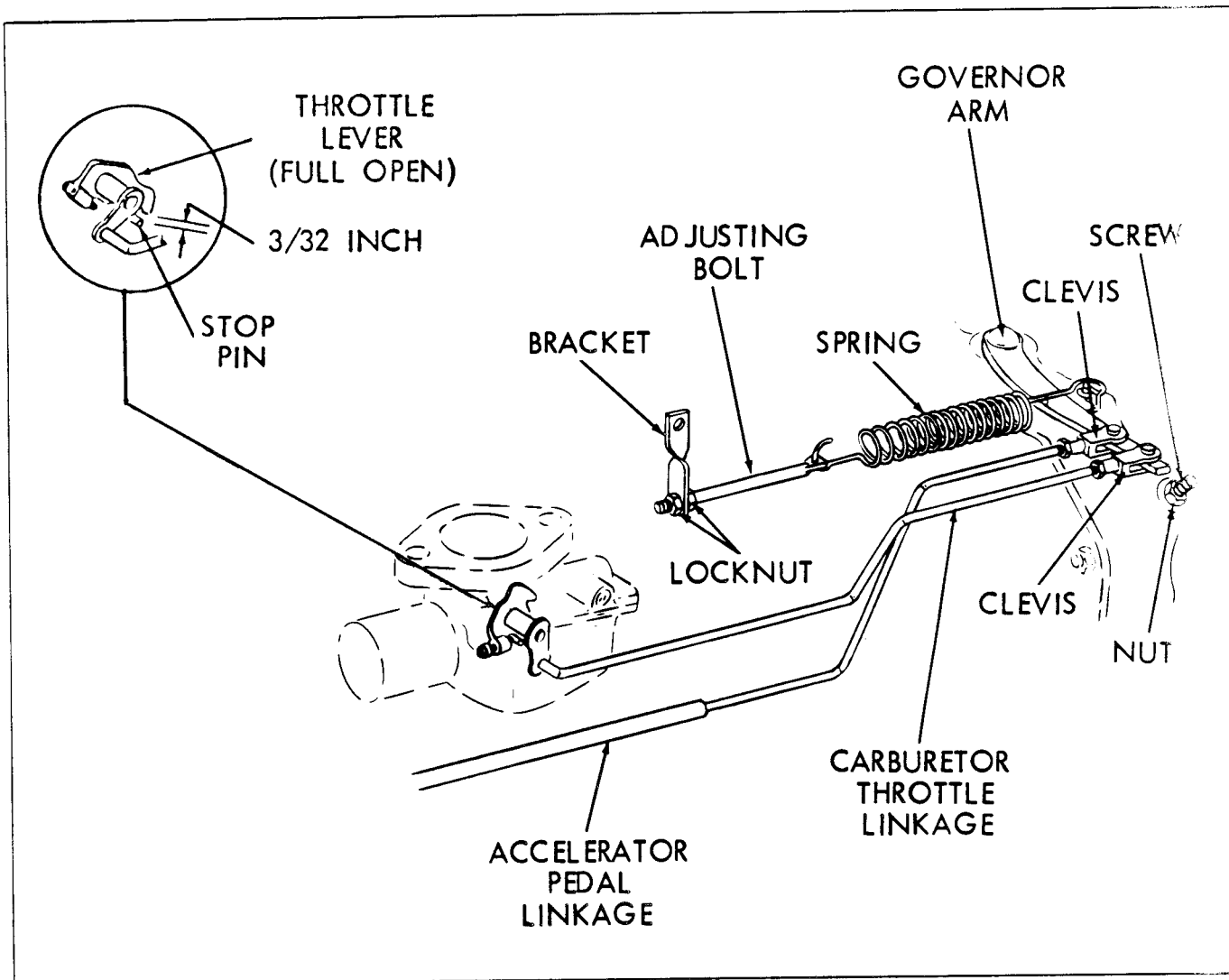

Plate 7764. Governor Adjustment

II. GOVERNOR ADJUSTMENT

With timing set on 4° after top dead center, and the carburetor properly adjusted to idle at 500 R.P.M., proceed with the following:

A. Loosen Governor Surge Screw Jam Nut and back Surge Screw out.

B. Disconnect Slip Tube Rod from Governor Arm by removing Clevis Pin.

NOTE

REMOVE CLEVIS PIN --- DO NOT LOOSEN CLEVIS JAM NUT.

C. Pull rod from Slip Tube Sleeve and thoroughly clean rod and sleeve. Lubricate rod with Graphite Grease after cleaning.

NOTE

THE SLIP TUBE ROD AND SLEEVE ASSEMBLY CANNOT FUNCTION PROPERLY IF IT IS BENT. THEREFORE, THE ASSEMBLY MUST BE CLEAN AND PROPERLY LUBRICATED TO CORRECTLY ADJUST THE GOVERNOR.

D. With the Slip Tube and Sleeve Assembly disconnected, the Governor Arm will move forward. Check the Carburetor Throttle Opening. There should be 3/32 inch clearance between the Full Throttle Opening Stop and Stop Pin on the carburetor.

If adjustment is necessary, adjust the Throttle Rod between carburetor and



INDUSTRIAL TRUCK DIVISION



LUBRICATION AND PREVENTIVE MAINTENANCE

governor arm until the specified clearance (3/32 inch between STOP and STOP PIN) is obtained.

E. Push the Governor Arm toward rear of machine until the Idle Stop Screw contacts Stop Pin on the carburetor. Rotate the Governor Surge Screw inwards until screw comes in contact with the Governor Shaft Lever (when holding the Governor Arm rearward) ---- Do Not Rotate Screw So Far That The Idle Stop Screw Moves Away From Stop Pin. When correct surge screw adjustment is obtained, tighten jam nut.

F. With the use of an Electric Tachometer, start engine (Warm up to normal temperature) and check for NO -- LOAD 2350 R.P.M.

NOTE

GOVERNED R.P.M. SHOULD BE CHECKED WITH THE SLIP TUBE ROD DISCONNECTED BETWEEN THE ACCELERATOR LINKAGE AND THE GOVERNOR ARM.

If adjustment is necessary, adjust the Governor Spring, see Plate 7764.

G. Install Slip Tube over rod. Attach Rod Clevis to Governor Arm with Clevis Pin.

IMPORTANT

WITH IGNITION OFF, DEPRESS ACCELERATOR PEDAL AND CHECK THROTTLE OPENING. IF THERE IS MORE THAN 3/32 INCH CLEARANCE BETWEEN THE FULL THROTTLE OPENING STOP AND STOP PIN (ON THE CARBURETOR), ADJUST THE SLIP TUBE CLEVIS, OR ACCELERATOR PEDAL LINKAGE TO OBTAIN THIS DIMENSION.

H. Start engine and again check for NO - LOAD 2350 R.P.M.

If specified R.P.M. is not obtained, check for binding linkage, bent Slip Tube, etc., free up, straighten or repair as required.

STARTING MOTOR

1. Remove end plate (or Brush Cover) from starter. Use a wire hook to lift a brush spring and remove brush from holder. Compare brush size with that of a new brush. If brush is worn beyond half the original size, or if brushes are jammed, chipped, or broken they must be replaced.

CAUTION

NEVER ALLOW SPRING TO SNAP DOWN ON BRUSHES.

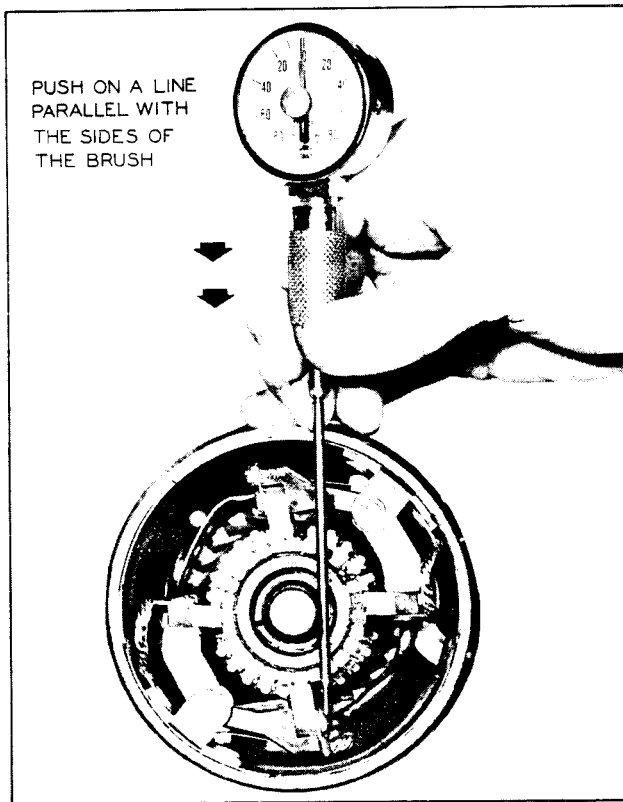

Plate 6449 Checking Brush Spring Tension

2. Check for Brush Spring Tension, refer to Specifications. Refer to the following procedures for checking spring tension.

Measuring Brush Spring Tension - Reaction Type Brushes. Hook the scale under the brush spring near the end and push or pull on a line parallel to the sides of the brush. To assist in telling the exact instant that the pressure is relieved, a small strip of paper can be placed under the brush. Pull slightly on the paper and the paper will slip out at the correct instant for reading the spring scale.

Measuring Spring Tension - Swinging Type Brushes: Hook the spring scale under the brush screw tight

against the brush and push or pull on a line parallel to the sides of the brush. Take the reading just as the brush leaves the commutator. Pulling slightly on a strip of paper which has been placed under the brush will indicate when the brush leaves the commutator and the correct instant for reading the spring scale.

3. If commutator is glazed or dirty, clean with a strip of No. 00 sandpaper. Blow out all dirt and grit with compressed air.

CAUTION

DO NOT USE EMERY CLOTH TO CLEAN COMMUTATOR.

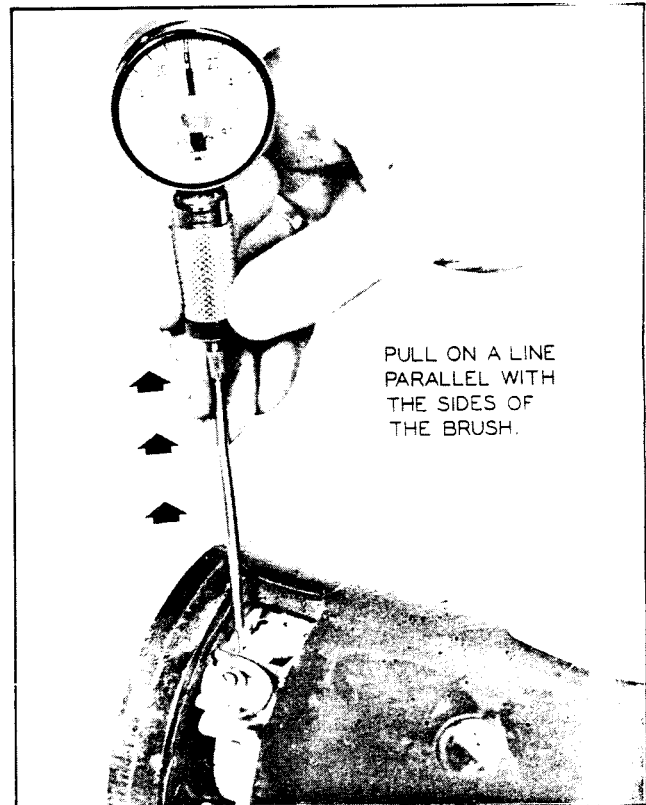

Plate 6450. Checking Brush Spring Tension

Condition Test: Use one of the two following methods to determine whether the starting motor should be removed from the engine for inspection, service or replacement.

1. First Method: Operate the starting motor by disconnecting the battery cable from the solenoid switch and holding the cable terminal firmly against the starting motor terminal, using a battery known to be fully charged and in good condition. To do this it will be necessary to remove the solenoid switch.

2. If the motor reacts correctly, and the drive mechanism engages and disengages each time the starting motor is operated, the starting motor is in good condition.

3. If motor does not react properly, it must be removed for inspection or replacement.

4. Second Method: Using a voltmeter and a battery (fully charged) that is in good condition, connect positive lead of test voltmeter to positive terminal of battery and negative lead of voltmeter to negative (grounded) terminal of battery. Record voltmeter reading. Now pull high-tension wire from ignition coil so engine will not start when starter is engaged. Connect positive lead of test voltmeter to ground and negative lead of test voltmeter to starter switch terminal. Turn ignition switch to start position and note voltmeter reading. Compare this reading with the previously recorded reading. If the voltage drop is more than 4 volts, or if the second reading is below 8 volts, the starting motor should be removed from the engine for further testing and repair, or replacement.

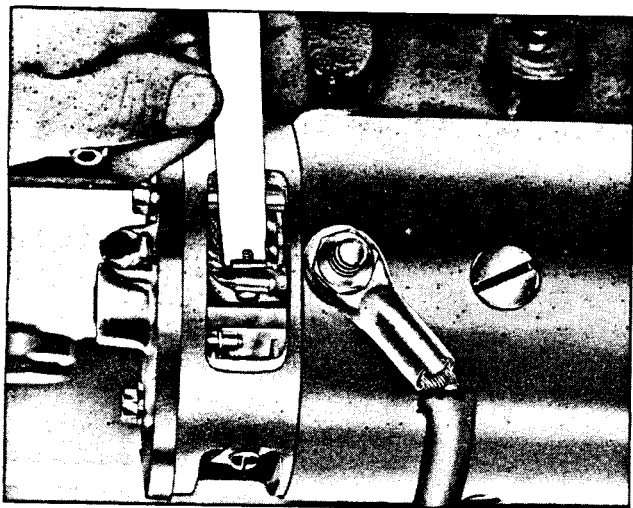

Plate 3436. Seating Brushes

N O T E

BLOW OUT ABRASIVE PARTICLES AFTER SEATING BRUSHES.

STARTER LUBRICATION

The starter end frame bushing (Commutator End) should be lubricated every 30,000 starts or at least once a year (2000 operating hours). Use American Oil Molyth number 2 grease or its equivalent.

C A U T I O N

DO NOT OVER-LUBRICATE, AS EXCESS GREASE IS DETRIMENTAL TO STARTER COMPONENTS — OVER-LUBRICATING MAY CAUSE GREASE TO BE FORCED ONTO THE COMMUTATOR AND BRUSHES.

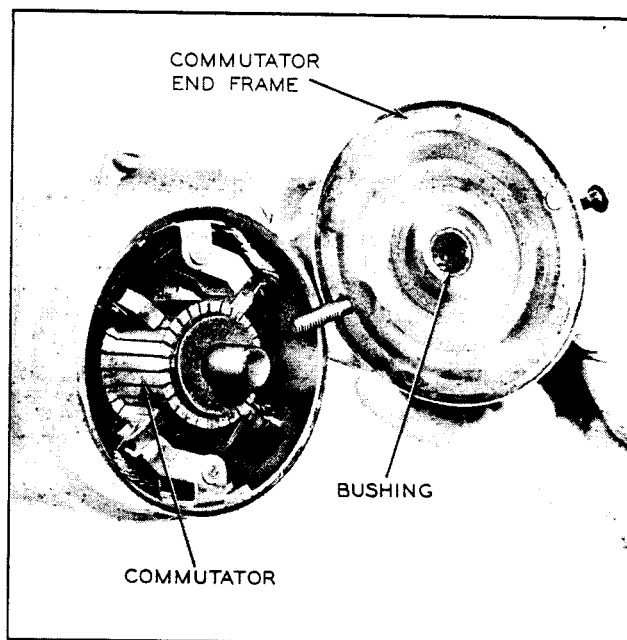

Plate 6236. End Frame Bushing Lubrication-Typical Starter

GENERATOR

1. Remove end plate (or Brush Cover) from generator. Use a wire hook to lift a brush spring and remove brush from holder. Compare brush size with that of a new brush. If brush is worn beyond half the original size, or if brushes are jammed, chipped, or broken they must be replaced.

CAUTION

NEVER ALLOW SPRING TO SNAP DOWN ON BRUSHES.

New brushes can be seated with a brush seating stone. When held against the revolving commutator, the abrasive material carries under the brushes, seating them in a few seconds. Blow out abrasive particles after seating brushes. See Plate 3436.

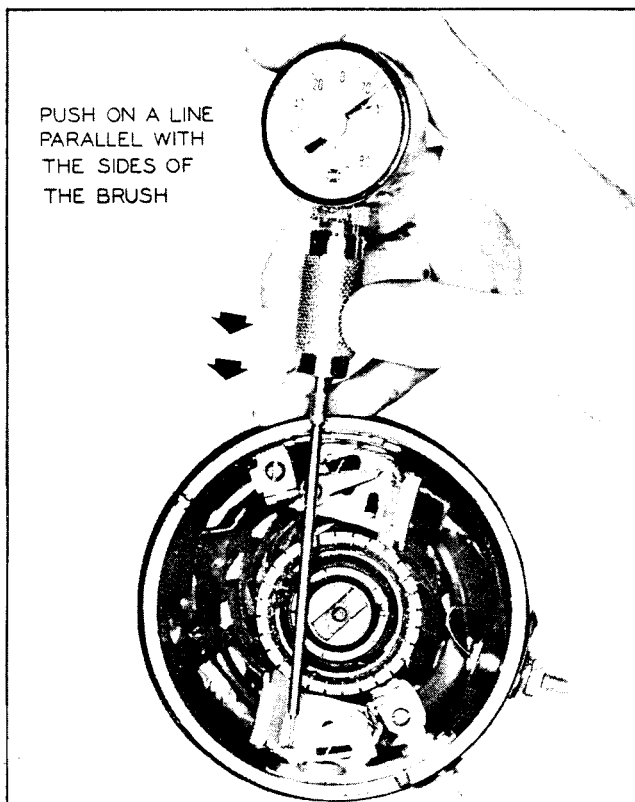

Plate 6451. Checking Brush Spring Tension

Using a spring scale, check for proper brush spring tension. Refer to Specifications. Refer to the following procedures for checking spring tension.

Measuring Brush Spring Tension - Reaction Type Brushes. Hook the scale under the brush spring near the end and push or pull on a line par-

allel to the sides of the brush. To assist in telling the exact instant that the pressure is relieved, a small strip of paper can be placed under the brush. Pull slightly on the paper and the paper will slip out at the correct instant for reading the spring scale.

Measuring Spring Tension - Swinging Type Brushes:

Hook the spring scale under the brush screw tight against the brush and push or pull on a line parallel to the sides of the brush. Take the reading just as the brush leaves the commutator. Pulling slightly on a strip of paper which has been placed under the brush will indicate when the brush leaves the commutator and the correct instant for reading the spring scale.

3. If commutator is glazed or dirty, clean with a strip of No. 00 sandpaper. Blow out all dirt and grit with compressed air.

CAUTION

DO NOT USE EMERY CLOTH TO CLEAN COMMUTATOR.

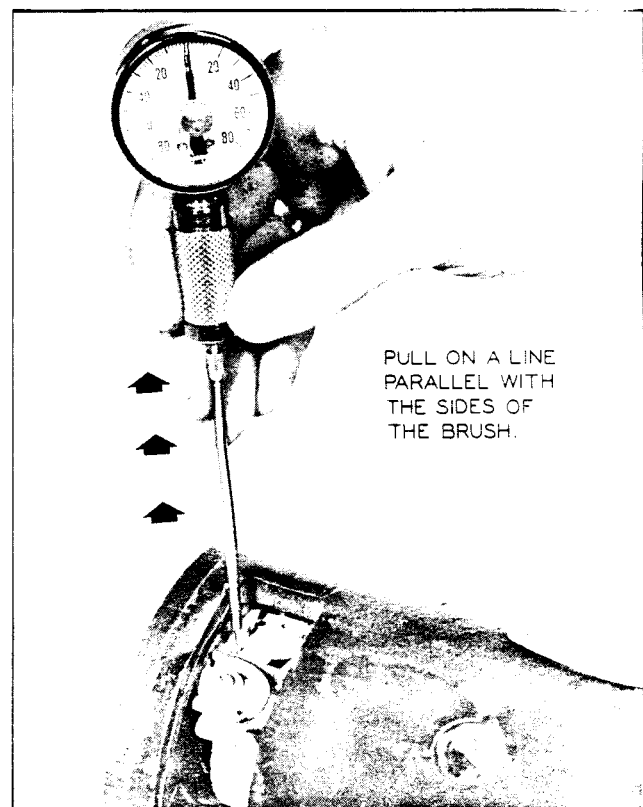

Plate 6450. Checking Brush Spring Tension

NOTE

BLOW OUT ABRASIVE PARTICLES AFTER SEATING BRUSHES.

REGULATOR

Inspect regulator leads for frayed or worn condition. Check to make certain that leads are tight and securely mounted.

WIRING

Check all wires for loose or corroded connections and for fraying. Replace defective wires.

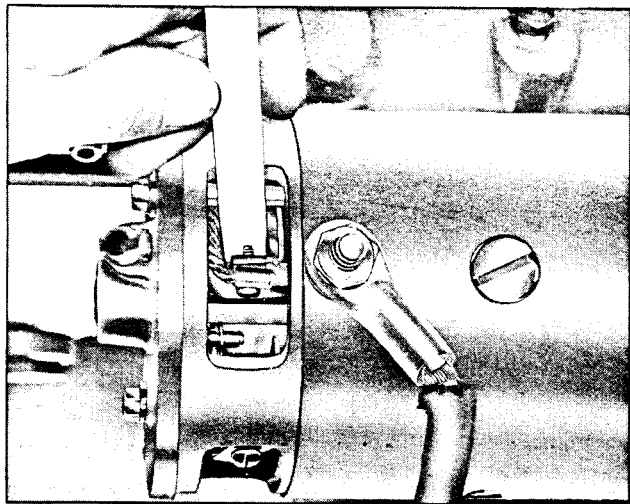

Plate 3436. Seating Brushes

LUBRICATION AND PREVENTIVE MAINTENANCE

CLEAN AND REPACK AXLE ENDS

Every 1000 operating hours remove and repack the axle ends with NLGI #1 (Amolith grease #1 or its equivalent).

1. Tilt upright back. Place solid heavy blocks under each upright rail. Tilt upright forward until vertical to the floor. This should allow the drive wheels to clean the floor. Remove drive wheels.

2. Remove hub cap, cotter pin, washer, spindle nut and pull hub assembly from spindle.

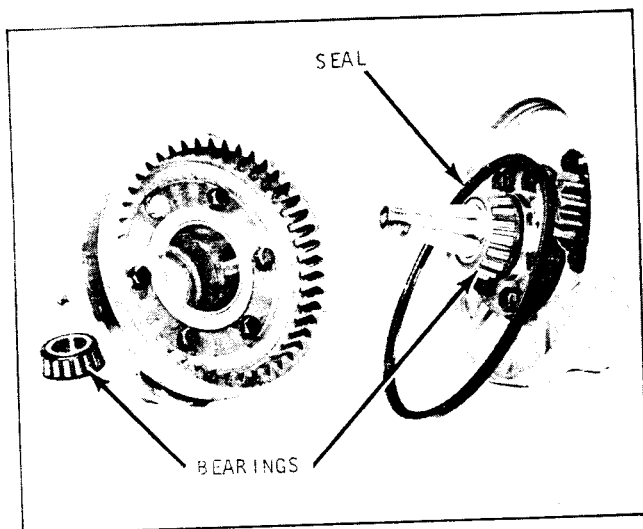

Plate 6892. Axle End Assembly

3. Remove bearings and clean in a Stoddard type cleaning solvent. Slosh bearings up and down in solvent. Remove and tap large side of bearing against a block of wood to dislodge solidified particles of lubricant. Repeat operation until bearings are thoroughly clean. Blow bearings dry with compressed air. Direct air stream across bearing to avoid spinning. Slowly rotate bearing by hand to facilitate drying. Dip bearings in gear oil and wrap in paper until they are to be reinstalled.

4. Clean ring gear, pinion drive shaft, hub assembly, spindle and spindle support.

5. Inspect seal for cuts, scratches and nicks. If is necessary to replace seal if such a condition is found.

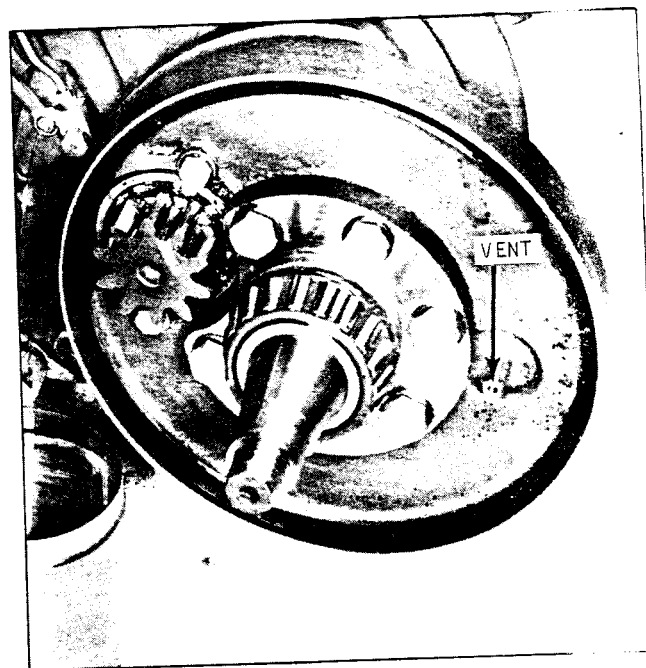

Plate 6893. Axle End Vent

6. Repack each axle end (bearings, spindle, ring gear and pinion) with one pound of NLGI #1 (Amolith grease #1 or its equivalent). Check the axle end vent for obstructions. the vent must be open.

7. Install bearings, seal and hub assembly.

8. Install washer, spindle nut and hub cap.

9. Tilt upright back and remove blocking.

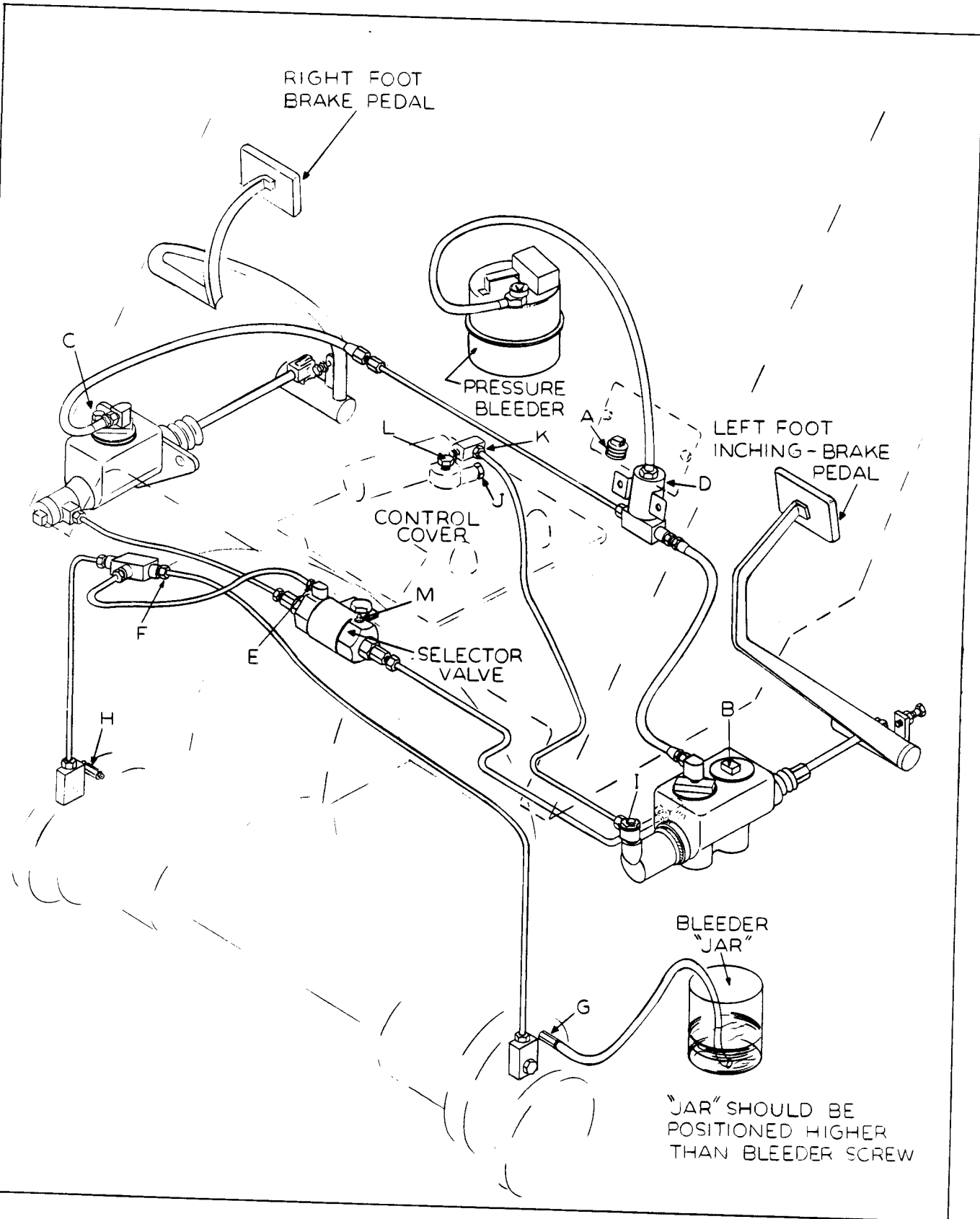

Plate 7760. Bleeding Brake System



INDUSTRIAL TRUCK DIVISION



LUBRICATION AND PREVENTIVE MAINTENANCE

BRAKE BLEEDING PROCEDURE

NOTE

Proper operation of the hydraulic brake system requires a solid column of fluid without air bubbles at all points in the pressure system. Under certain conditions it becomes necessary to bleed fluid from the system in order to expel air bubbles which have become mixed with the fluid. The necessity for bleeding is indicated by a soft or spongy pedal, or at any time a brake line is removed (or broken) the system must be bled.

THE KEY LETTERS IN PARENTHESIS ARE SHOWN ON PLATE 7760.

Step 1. Tilt upright back. Place solid heavy blocks under each upright rail. Tilt upright forward until vertical to the floor. This should allow the drive wheels to clear the floor.

Step 4. Remove the vented cap (A) and attach the pressure bleeder line at point (D). Pressurize the tank to 10-12 pounds. Loosen cylinder cap (B) and plug (C). Allow fluid to escape until all traces of air are gone. Tighten cap and plug (C).

WARNING

WHEN NECESSARY TO REMOVE THE DRIVE WHEELS FROM THE MACHINE TO GAIN ACCESS TO THE WHEEL CYLINDER BLEEDER SCREWS, BLOCKING OF ADEQUATE STRENGTH TO SUPPORT THE MACHINE MUST BE PLACED UNDER THE FRAME PRIOR TO WHEEL REMOVAL. THIS WILL PREVENT PERSONAL INJURY OR DAMAGE TO THE EQUIPMENT DUE TO ANY UNINTENTIONAL LOWERING OF THE MACHINE DURING THE BLEEDING OPERATION.

Step 5. Loosen tube nut (E) and allow fluid to escape until all traces of air are gone. Tighten tube nut (E). Repeat this procedure on tube nut (F).

WARNING

DEFLATE PNEUMATIC TIRES PRIOR TO REMOVAL OF WHEELS. THIS IS BEST ACCOMPLISHED BY REMOVING THE VALVE STEM CORE.

Step 6. Install a bleeder hose on bleeder screw (G) and submerge the unattached end of the hose in a clean transparent jar containing several inches of brake fluid. NOTE: DURING BLEEDING THE JAR SHOULD BE ELEVATED TO A POSITION HIGHER THAN THE BLEEDER SCREW MAKING SURE THAT THE END OF THE HOSE REMAINS SUBMERGED IN THE FLUID AT ALL TIMES. Loosen bleeder screw (G) and allow fluid to flow until all traces of air are gone. Tighten bleeder screw. Repeat this procedure on opposite wheel cylinder bleed screw (H).

Step 2. Check the brake pedal free travel. The right foot brake pedal should have 3/16 to 1/2 inch free travel. The left foot combination inching-brake pedal should have 3/16 to 5/16 inch free travel. The above dimensions must be maintained to allow each cylinder piston to return to its normal released position after each brake application. Adjust free travel at each master cylinder push rod if necessary.

Step 7. Loosen plug (I) and allow fluid to escape until all traces of air are gone. Tighten plug.

Step 8. Loosen screw (J) at the inching control cover and allow fluid escape until all traces of air are gone. Tighten screw. Repeat this procedure in sequence on tube nut (K) and screw (L).

Step 9. Attach a bleeder hose to the bleed screw (M) which is positioned at the top of the selector valve. Using jar as outlined in Step 6, loosen the screw and allow fluid to flow until all traces of air are gone. Tighten screw and remove bleeder hose.

NOTE

ON MACHINES #1 THRU 300 BUILT IN LOT 625 IT WILL BE NECESSARY TO APPLY LEFT FOOT BRAKE PEDAL PRESSURE TO PROPERLY BLEED AT POINT (M).

Step 3. To properly bleed the system it is recommended that a pressure bleeder containing approximately two quarts of S.A.E. 70 R3 (Clark Part # 1800200) heavy duty brake fluid be connected to the system.



INDUSTRIAL TRUCK DIVISION



LUBRICATION AND PREVENTIVE MAINTENANCE

MANUAL BLEEDING

If a pressure bleeder is unavailable the system may be bled manually. The following steps should be followed in sequence and it must be remembered that the brake pedals should be depressed slowly and held in the down position until the line connections or bleeder screws are securely tightened. This prevents the possibility of air being drawn back into the system during the bleeding operation. Keep the cylinders full or nearly full of fluid during manual bleeding.

Step 1. Apply foot pressure on right pedal and loosen tube nut (E). Tighten tube nut (E) when pedal reaches its down position. Repeat this procedure until the escaping fluid is free of all traces of air.

Step 2. Repeat above procedure at tube nut (F).

Step 3. Install a bleeder hose on bleeder screw (G) and submerge the unattached end of the hose in a clean transparent jar containing several inches of brake fluid. Holding the jar higher

than the bleeder screw, (be sure unattached end of hose remains submerged in fluid) apply foot pressure to the right pedal and loosen bleeder screw. Tighten bleeder screw when pedal reaches its down position. Repeat this procedure until the fluid entering the jar is free of all traces of air.

Step 4. Install bleeder hose on opposite wheel cylinder bleed screw (H) and proceed as in Step 3.

Step 5. Exert left foot brake pressure and loosen plug (I). When foot pedal reaches its down position, tighten plug. Repeat this procedure until all traces of air are gone.

Step 6. In sequence follow the procedure outlined in Step 5 at screw (J), tube nut (K) and screw (L).

Step 7. Attach a bleeder hose to the bleeder screw (M) which is positioned at the top of the selector valve. Using a bleeder jar as outlined in Step 3, apply foot pressure to the left inching-brake pedal, loosen screw (M). When pedal reaches its down position, tighten screw (M). Repeat this procedure until all traces of air are gone.

BRAKE ADJUSTERS (2ND. DESIGN)

When the brake system is operating properly, the cam like action of the reaction arm allows self-adjustment for the total thickness of the brake linings, without any noticeable increase in brake pedal free travel. The self-adjustment feature eliminates the need for manual adjustment of the brakes.

When the brake linings become worn beyond their designed limits there will be a noticeable change in the brake pedal effort required to stop the machine or, brakes will become noisy during application. If either of these conditions exist the axle ends should be removed so an inspection of the brake linings can be made to determine their further serviceability.

Before installing new brake linings the adjuster arm mounting bolt torque should be checked with a torque wrench. The bolt should not turn in the backing plate until a minimum of 40 lb. inches or a maximum of 50 lb. inches is reached. See Plate 7198 for correct procedure.

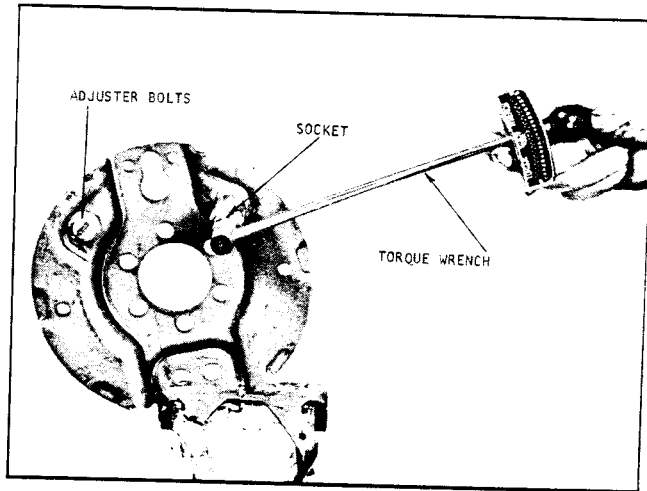

Plate 7198. Checking Adjuster Arm Torque

The backing plate and adjuster arm components must be clean, dry and free from rust when this torque test is made.

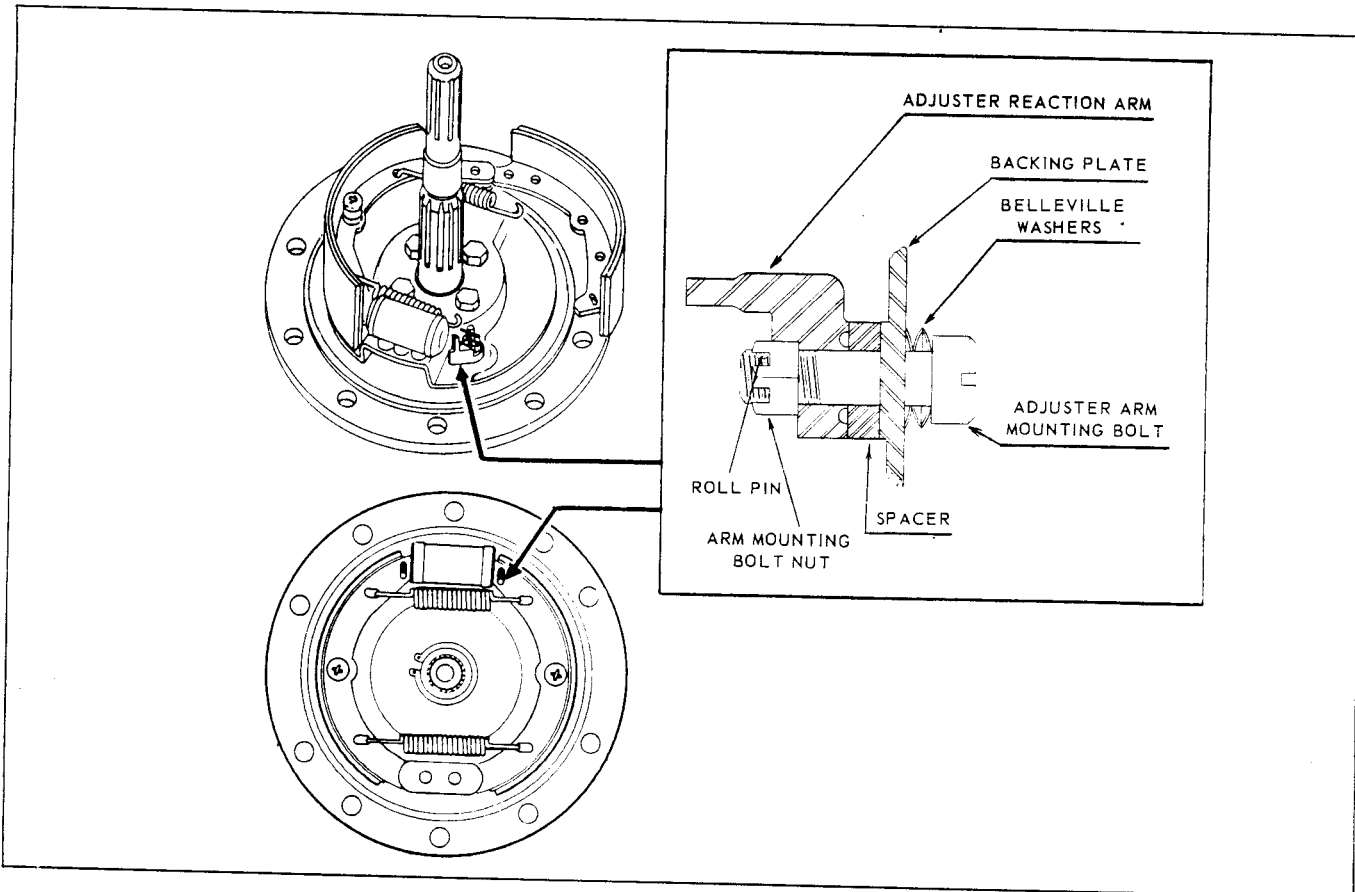

Plate 7494. Automatic Brake Adjusters

BRAKE ADJUSTERS (1ST DESIGN)

The mechanical brake adjusters maintain proper brake lining clearance until such time as the brake linings require replacement.

If it is found that during brake applications the brake pedal travel has gradually become excessive (and the system has been properly bled and pedal free travel is correctly adjusted) the brake linings are worn beyond their designed

limits and the mechanical adjusters can no longer maintain proper brake lining clearance. If lining wear has reached this point and replacement of linings are necessary report to designated person in authority. When the Adjuster Reaction Arm INDEX WASHER "High Spot" rotates past the backing plate index washer "High Spot", excessive pedal travel will be noticed indicating that the brake linings have worn beyond their designed limits.

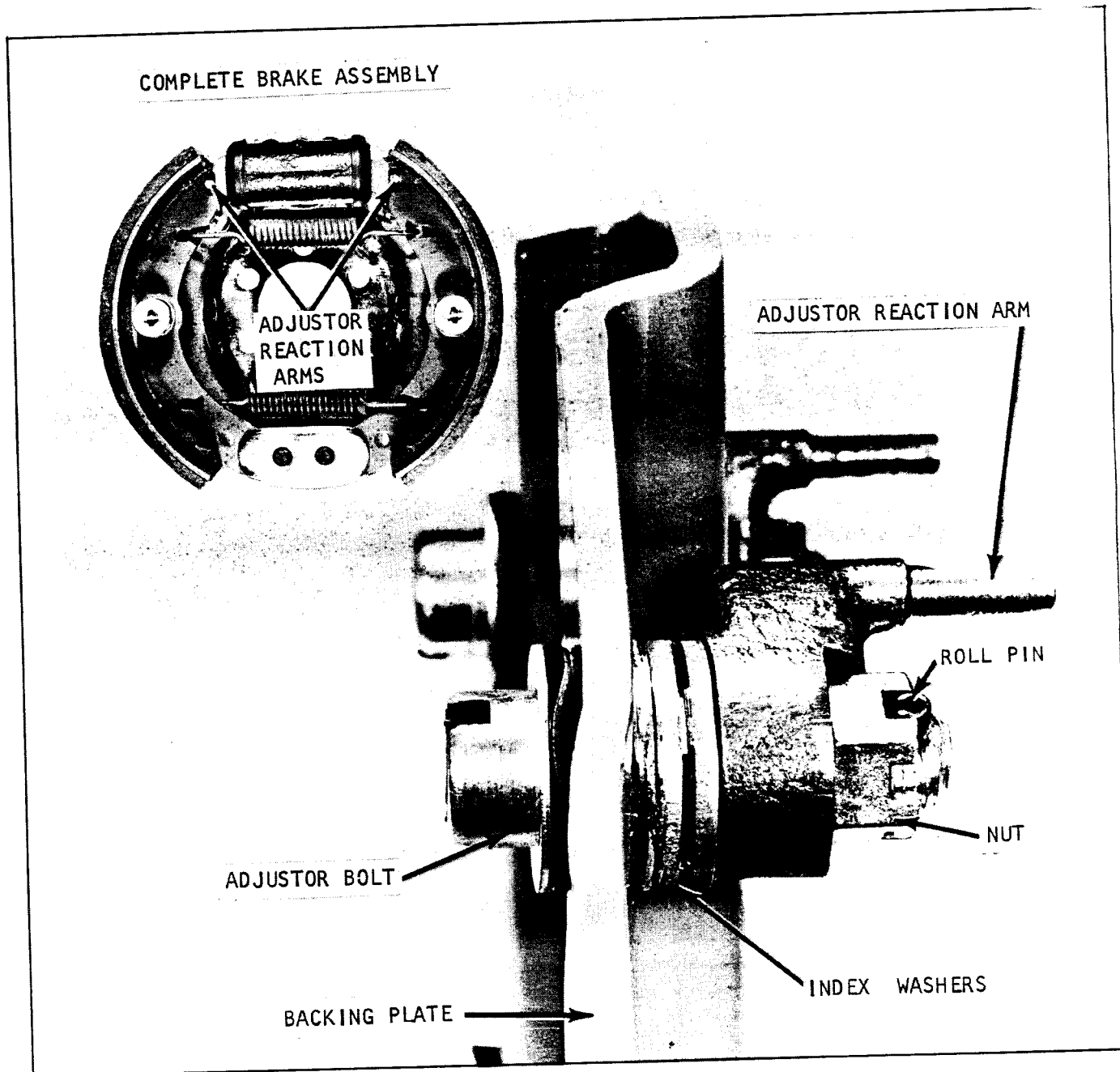

HAND BRAKE ADJUSTMENT

The brake on this model is a "V" pulley type drum mounted on the end of the transmission pinion shaft with a "V" shaped brake shoe that fits into the drum groove. When lifting hand brake lever, pressure is applied to the brake shoe which presses the shoe against (into) the drum.

To adjust the hand brake, refer to Plate 5270 and proceed as follows:

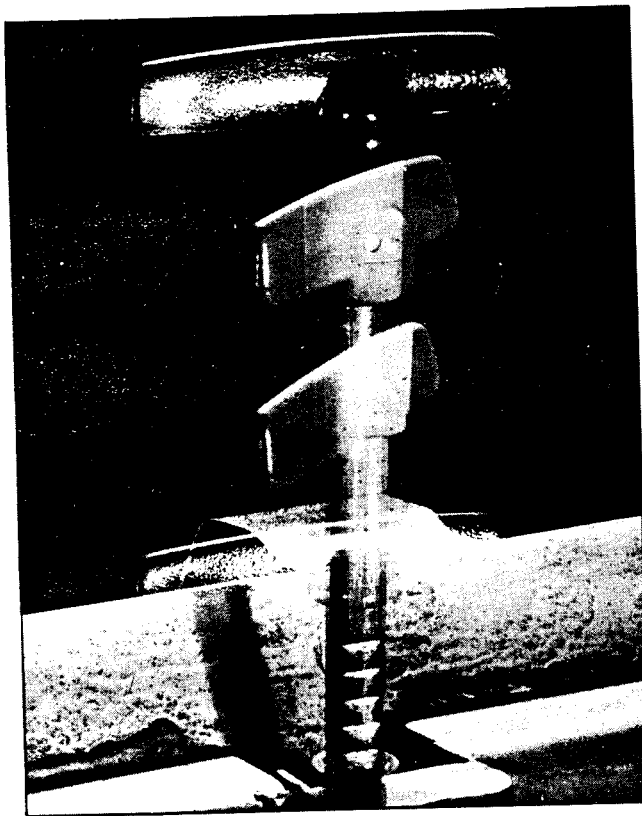

Plate 7482. Hand Brake (Actuating) Lever

Adjustment is made at the Parking Brake Draw Rod LOCK SLEEVE and LOCK NUT, Plate 5270.

These items protrude downward through the bottom-side of the Converter Housing.

1. Loosen the Lock Nut several turns.
2. Rotate the Lock Sleeve counterclockwise to close gap between brake shoe and brake drum.
3. Hold the Lock Sleeve and tighten the Lock Nut until snug against Cam Lever, then back off lock nut one half to three quarters of turn.
4. Test Adjustment: Test adjustment while occupying the driver's seat.

Fully apply the hand brake. Full application of hand brake should require 1 1/2 to 2 inches of travel. If the lever travel exceeds this amount the linkage should be adjusted.

Test Parking Brake Effectiveness - must be capable of holding the truck, with full rated load, on a 15% grade.

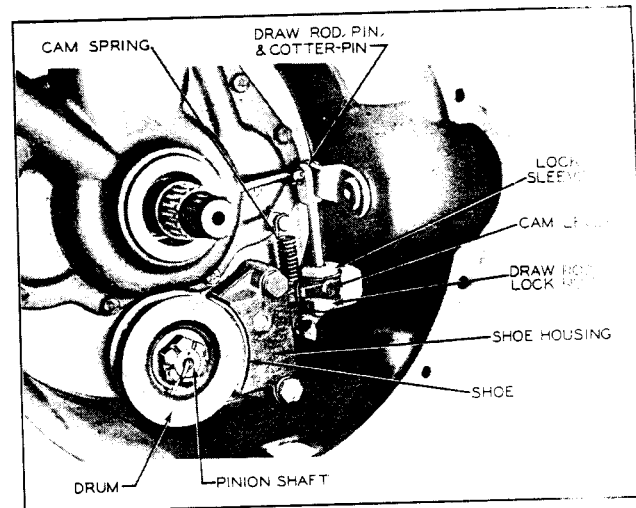

Plate 5270. Adjusting Brake

COOLING SYSTEM

Radiator Pressure Caps:

WARNING

USE EXTREME CARE IN REMOVING THE RADIATOR PRESSURE CAP. IN PRESSURE SYSTEMS, THE SUDDEN RELEASE OF PRESSURE CAN CAUSE A STEAM FLASH AND THE FLASH, OR THE LOOSENED CAP CAN CAUSE SERIOUS PERSONAL INJURY. LOOSEN CAP SLOWLY AND ALLOW STEAM TO ESCAPE.

1. Inspect pressure cap gasket and radiator filler neck to be sure they are providing a proper seal. If the rubber face of the valve is defective, a new cap should be installed.

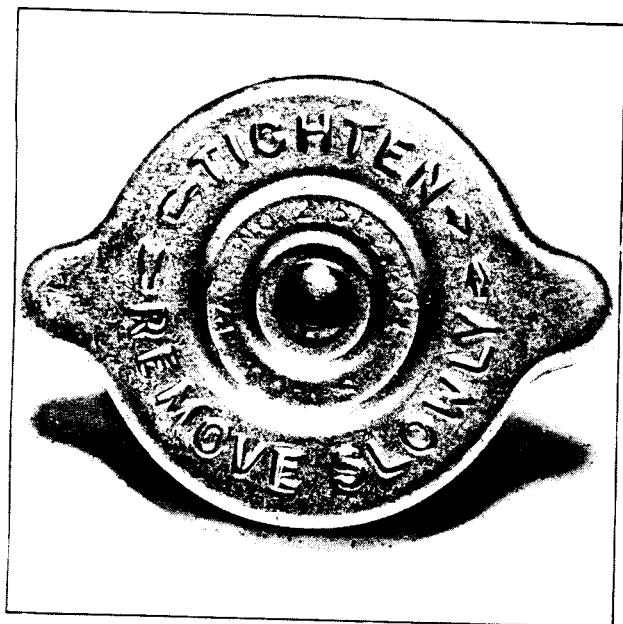

Plate 6458. Radiator Pressure Cap

2. Inspect pressure cap for freedom of operation.

Pressure caps employ a spring loaded, rubber-faced valve which presses against a seat in the radiator top tank. Pressure caps employ either a vacuum valve held against its seat under spring pressure, or a weighted vacuum valve which hangs open until forced closed by a surge of vapor or coolant. Check to be sure components are free to operate.

NOTE

IF A NEW CAP IS REQUIRED, ALWAYS INSTALL A CAP OF THE SAME TYPE AND PRESSURE RATING. PRESSURE RATING 7 LB.

3. Inspect for dented or clogged overflow pipe. To remove clogged material, run a flexible wire through pipe until obstruction is removed.

When a pressure cap opens the sudden surge of vapor or liquid must pass thru the overflow pipe. If the pipe is dented or clogged, the pressure developed by the obstruction may cause damage to radiator or hoses.

Inspect and Clean Cooling System:

Check hose connections for coolant leaks as well as air leakage. Air leakage around hose connections allows oxygen into the system which is a major factor in corrosion.

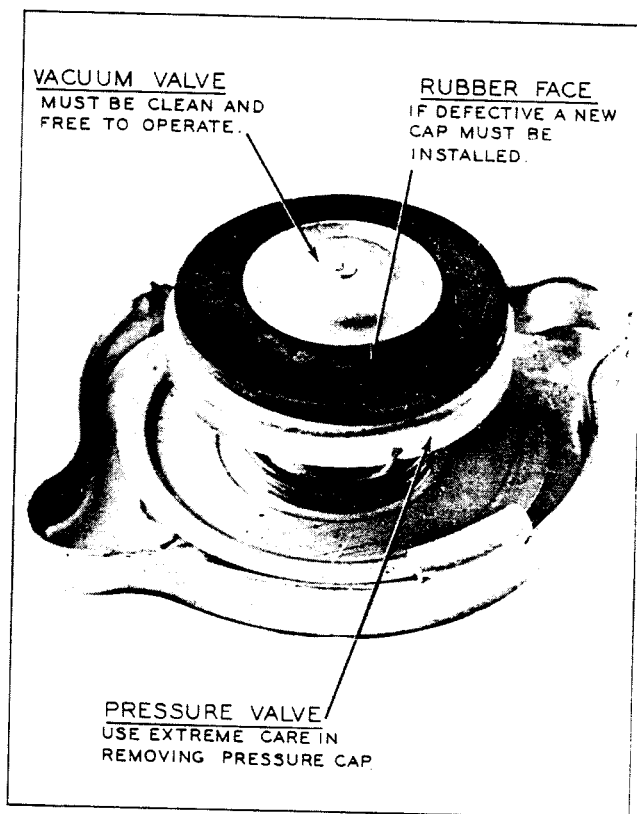

Plate 6459. Pressure Cap Gasket, Valve and Valve Gasket

NOTE

EXHAUST GAS LEAKAGE BETWEEN CYLINDER HEAD AND GASKET ALSO RESULTS IN CORROSION. IF EXHAUST GAS DISCHARGES INTO COOLANT, THE COOLANT AND THE GAS COMBINE TO FORM A VARIETY OF ACIDS. IT IS THEREFORE IMPORTANT THAT CYLINDER HEAD STUD NUTS BE DRAWN DOWN TO SPECIFICATIONS AS INSTRUCTED IN "ENGINE TUNE-UP".

LUBRICATION AND PREVENTIVE MAINTENANCE

Using a washing soda solution, flush cooling system in the following manner:

1. Drain system.
2. Replace half of volume with fresh water. Refer to Specifications for capacity.
3. Boil other half of volume and add washing soda until no more will dissolve.
4. Add hot soda solution to cooling system (fill up).
5. Operate engine normally for 24 hours.
6. Drain, flush, refill with clean water to which a soluble oil has been added in a proportion of 1 ounce per gallon of water.

Maintaining the cooling system efficiency is important, as engine temperatures must be brought up to and maintained within satisfactory range

for efficient operation; however, must be kept from overheating, in order to prevent damage to valves, pistons and bearings. Continued overheating may cause internal damage, while continuously low operating temperature wastes fuel, increases engine wear and causes oil sludge and corrosion of engine parts.

Overcooling may be caused by operating conditions such as excessive idling, low speeds and light loads during cold weather. Overheating may be caused by faulty thermostat, clogged radiator or an improperly adjusted fan belt.

CAUTION

NEVER POUR COLD WATER OR COLD ANTI-FREEZE INTO THE RADIATOR OF AN OVERHEATED ENGINE. ALLOW THE ENGINE TO COOL AND AVOID THE DANGER OF CRACKING THE CYLINDER HEAD OR BLOCK. KEEP ENGINE RUNNING WHILE ADDING WATER.

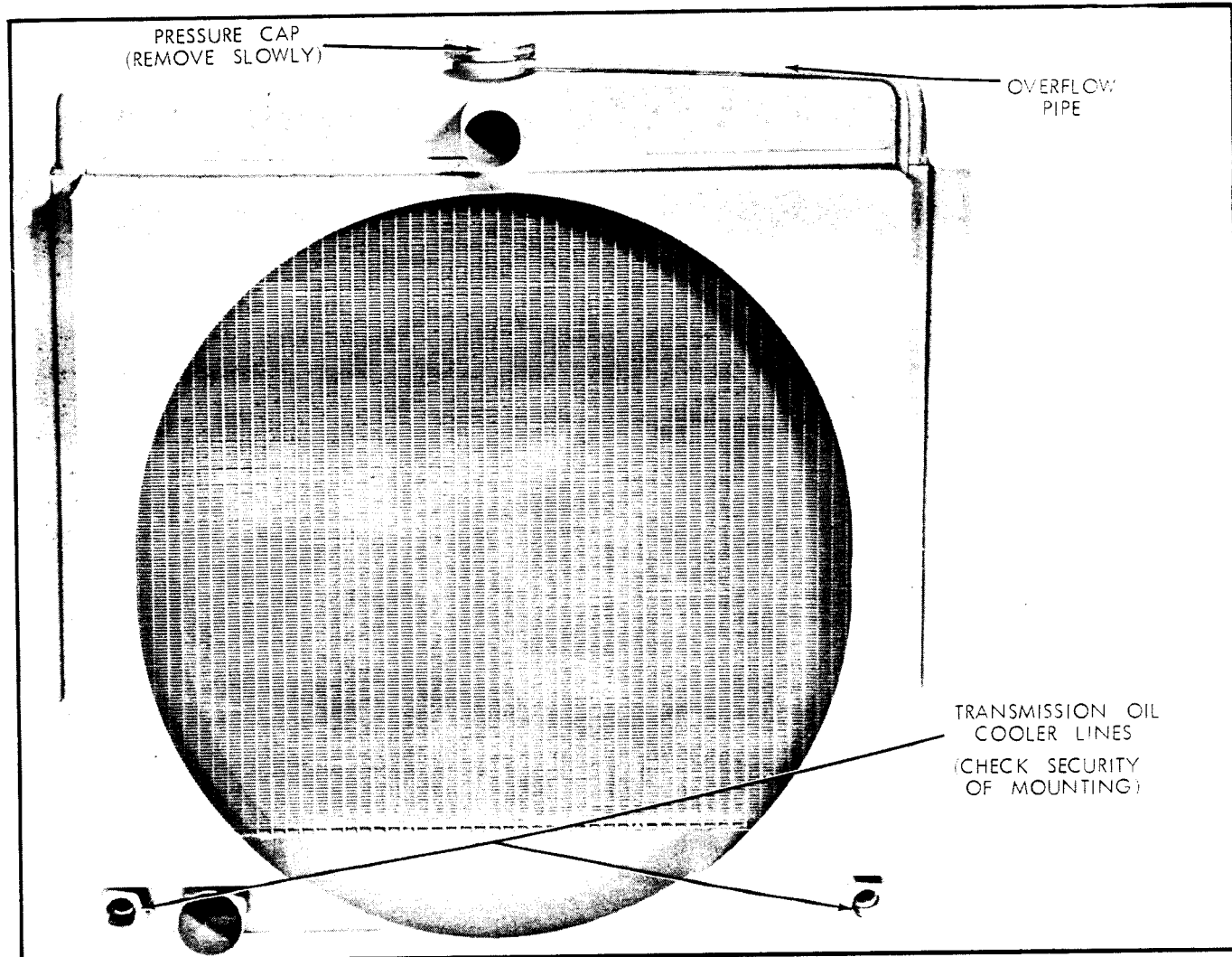

Plate 6460. Typical Radiator

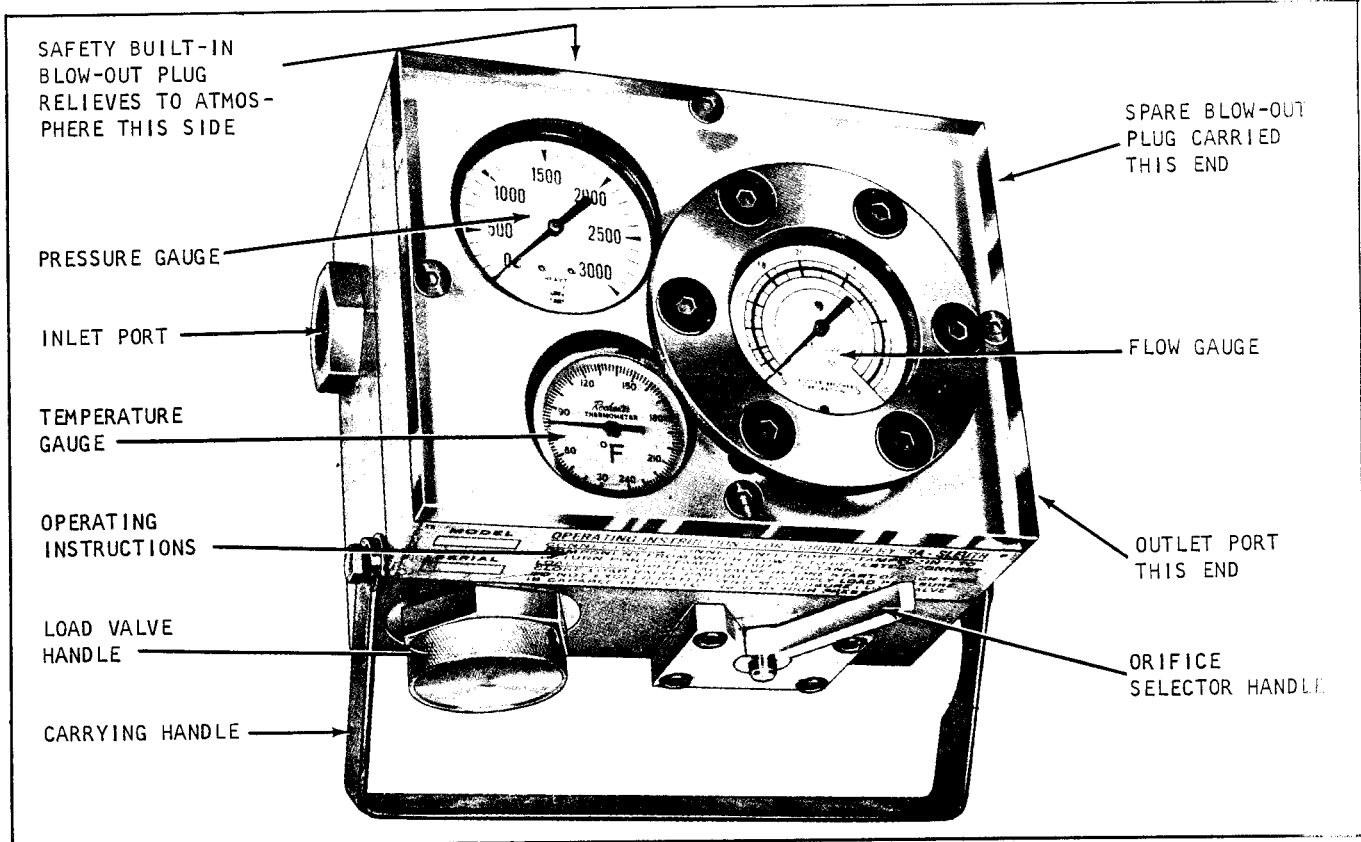

Plate 6747. Schroeder Hydraulic Circuit Tester CLARK PART NUMBER 1800060

PRESSURE GAUGE

Reads directly in pounds per square inch (PSI).

TEMPERATURE GAUGE

Reads directly in degrees Fahrenheit and indicates the temperature of the oil passing through the instrument.

FLOW GAUGE

Reads two scales in gallons per minute.

- 0 - 30 gallons
- 9 - 30 gallons

Read the scale that corresponds with the orifice selector position.

Turn orifice selector to the left (counter-clockwise) to read 10 gallon scale.

Turn orifice selector to the right (clockwise) to read 30 gallon scale.

You may switch from one scale to the other, while operating machine. Always start on 30 gallon scale.

LOAD VALVE

The load valve is a flow restrictor or shut off valve. Turning the valve to the right throttles flow through the Hydra-Sleuth, thus the operator may load a hydraulic pump or circuit to the desired test pressure, simulating work.

SAFETY PLUG

Located opposite the load valve this plug protects the Hydra-Sleuth and the test system from pressures in excess of 3200 PSI. When pressure becomes higher the plug will rupture and dump oil to atmosphere.

HYDRAULIC FLUID

Unless marked to the contrary, the unit is for use with petroleum, hydraulic fluid.

HOW TO CONNECT THE PORTABLE TESTER

Using a 1/2" hose or larger, connect tester INLET PORT to the flow to be tested. Connect the tester outlet port to reservoir fill port, or system return line.



INDUSTRIAL TRUCK DIVISION



LUBRICATION AND PREVENTIVE MAINTENANCE

HYDRA-SLEUTH ADJUSTMENTS BEFORE OPERATION

A. Depending on flow (GPM) to be checked choose proper orifice. (It is good practice to start always on 30 gallon scale.)

B. Fully open load valve by turning all the way to the left.

HYDRA-SLEUTH ADJUSTMENTS DURING OPERATION

1. Turn load valve to right to develop test pressures.

CAUTION

LOAD VALVE IS CAPABLE OF VERY HIGH PRESSURES.

A. Always start test with load valve fully open.

B. Do not exceed design pressure of system under test.

C. Keep load pressures within range of the Hydra-Sleuth pressure gauge.

MODEL

1550

SERIAL

23

OPERATING INSTRUCTIONS FOR SCHROEDER HYDRA-SLEUTH

CONNECTIONS: CONNECT INLET PORT (STAMPED "IN") TO COMPONENT FROM WHICH FLOW IS TO BE TESTED. CONNECT RETURN PORT (STAMPED "OUT") TO TANK.
LOAD VALVE: OPEN LOAD VALVE BEFORE START OF EACH TEST. CLOSE LOAD VALVE PARTIALLY TO APPLY LOAD PRESSURE. DO NOT EXCEED RATED SYSTEM PRESSURE (LOAD VALVE IS CAPABLE OF DEVELOPING VERY HIGH PRESSURES).
ORIFICE SELECTOR: TURN ORIFICE SELECTOR TO THE RIGHT TO READ 30 GALLON SCALE. TURN TO THE LEFT TO READ 10 GALLON SCALE. ALWAYS START UP WITH SELECTOR TOWARDS RIGHT ON 30 GALLON SCALE.

SCHROEDER BROTHERS
CORPORATION
NICHOL AVENUE, BOX 72 Mc KEES ROCKS (PITTSBURGH), PA.

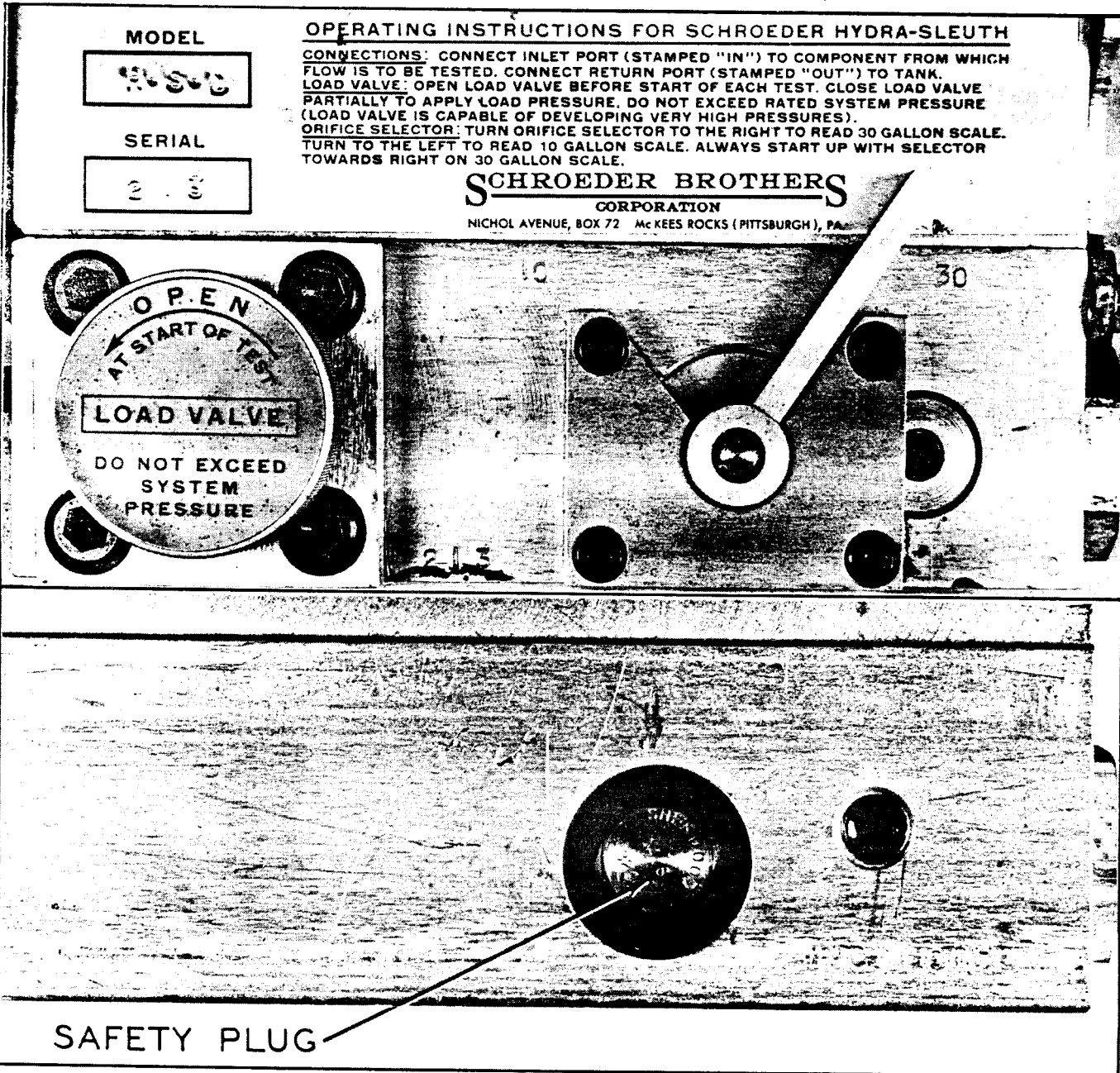

Plate 6748. Schroeder Hydraulic Circuit Tester

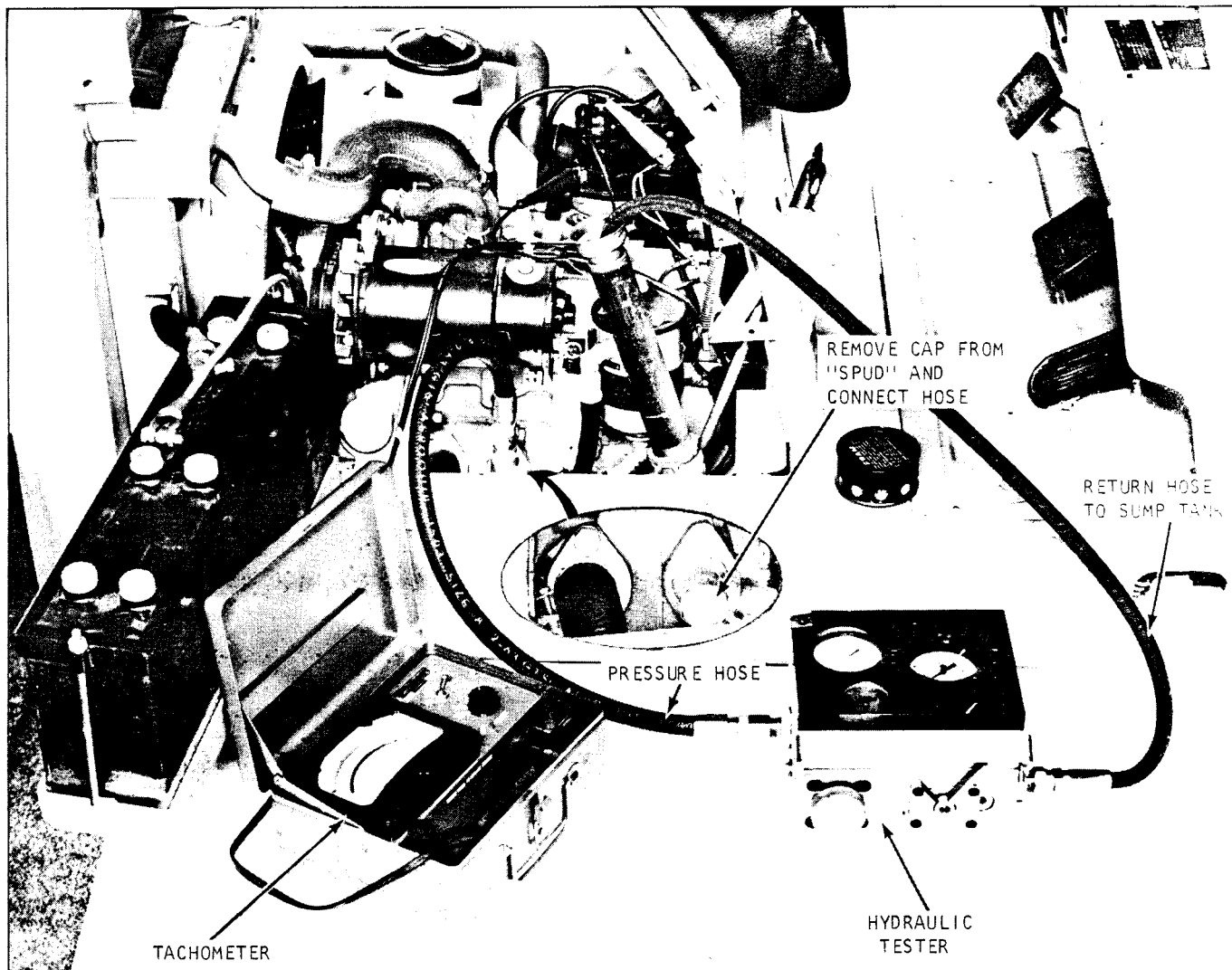

Plate 7841, Typical Hydraulic Circuit Tester Hookup

MAIN HYDRAULIC SYSTEM FLOW AND PRESSURE CHECKS

The hydraulic relief valve setting and the rate of flow being delivered by the hydraulic pump may be checked with a Hydraulic Circuit Tester, as shown on the above illustration.

1. Connect the pressure line from the tester to the "spud" connection on the outlet fitting of the hydraulic pump. (If a "spud" is not provided, install a "tee" in the outlet line for connection purposes.) Remove the sump tank breather and insert the return line from the tester into the sump.

2. Start engine and operate at governed rpm. Hold tilt lever back while gradually closing the load valve until pressure reaches 1500 psi. Continue to hold the tilt lever until hydraulic fluid reaches test temperature. (120° F.) With hydraulic fluid at this temperature make a note of the flow reading so it may be compared with the rate of flow found in the following step.

3. With engine operating at governed rpm, hold tilt lever in back position and continue to close the load valve until the pressure no longer increases on the gauge. (Close the load valve only enough to reach the peak pressure reading and avoid holding the tilt lever longer

than necessary to check rate of flow and pressure.)

The pressure reading will indicate the setting of the relief valve. The flow reading should be compared with the flow registered at 1500 psi. If pump or valve is worn, flow will drop off appreciably as pressure is increased. This is due to internal oil slippage in the components.

NOTE

SEVERELY VIBRATING GAUGES ARE OFTEN AN INDICATION OF ENTRAINED AIR -- CHECK FOR SUCTION LINE LEAKS.

If readings taken are not reasonably close to those listed in specifications, appropriate repairs should be made. Report to designated person in authority.

CHECKING PUMP PRESSURE WITH CONVENTIONAL HYDRAULIC PRESSURE GAUGE.

If a hydraulic circuit tester is unavailable, the pressure relief valve setting may be checked by installing a pressure gauge with a 0 to 4000 psi scale, at the discharge (pressure) line of the hydraulic pump.

CAUTION

INSTALL A "T" IN THE LINE FOR CONNECTION PURPOSES IF A "SPUD" IS NOT PROVIDED - CIRCUIT FROM PUMP TO VALVE MUST BE COMPLETED TO PREVENT "DEADHEADING" THE PUMP.

With upright tilted back and engine operating at governed rpm, hold the tilt lever momentarily and check the reading on the gauge. The reading should be reasonably close to the pressure listed in specifications for the pressure relief valve.

NOTE

ON SOME MODEL MACHINES IT MAY BE MORE CONVENIENT TO MAKE PRESSURE CHECK AT THE HYDRAULIC VALVE. SEE PLATES 7333 AND 7664.

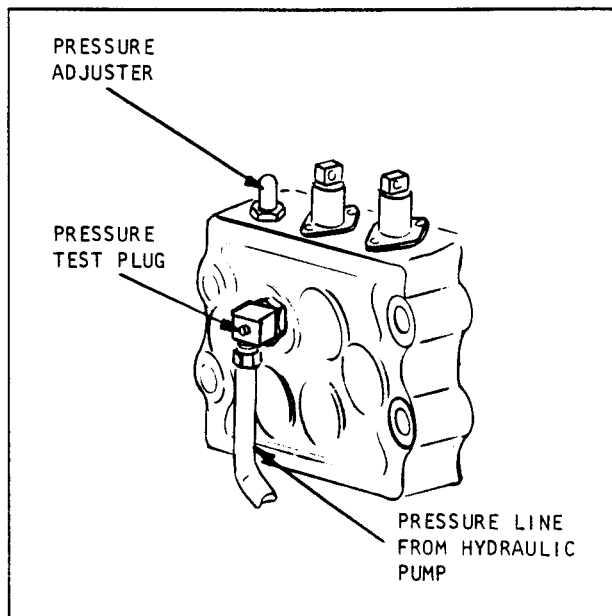

Plate 7664. Typical Hydraulic Valve

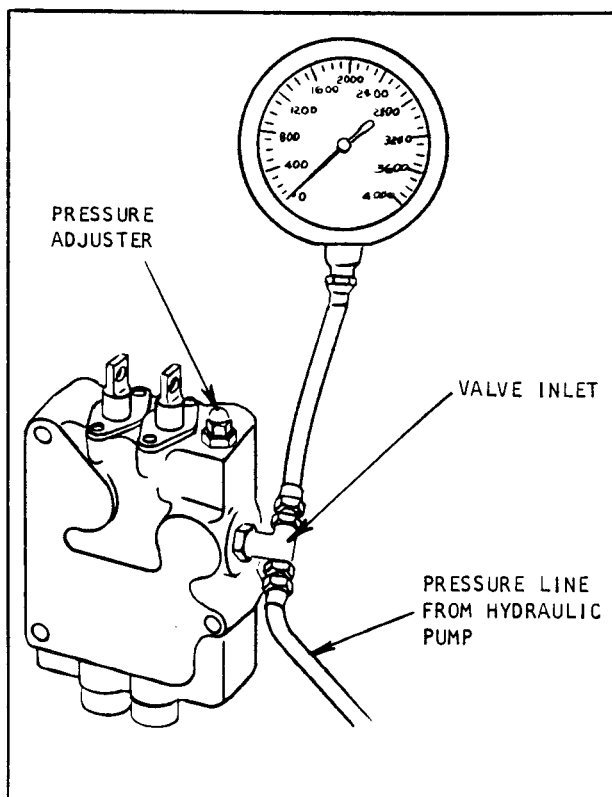

Plate 7333. Typical Hydraulic Valve

HYDRATORK TRANSMISSION PRESSURE CHECK AND STALL CHECK

MINIMUM TOOLS REQUIRED

- 1 - Pressure Gauge 0 -to- 250 P.S.I.
- 1 - Tachometer

1. Completely clean the truck and hydratork transmission before making pressure checks. This should include cleaning the complete machine with steam. Be sure the radiator and its tubes are clean externally and internally.

2. Check Transmission Fluid Level: Run machine in forward and reverse for about four minutes total. Stop engine and check fluid level. Fill if necessary to the "FULL" mark on the Transmission Dipstick.

3. Check Inching-Brake Pedal Free Travel: The hydraulic inching-brake pedal should have 1/4 inch free travel. Pedal free travel should be measured from top pedal position to where pedal meets resistance from the master cylinder when depressing pedal by hand. Refer to page 100H 302 for Pedal Free Travel illustrations.

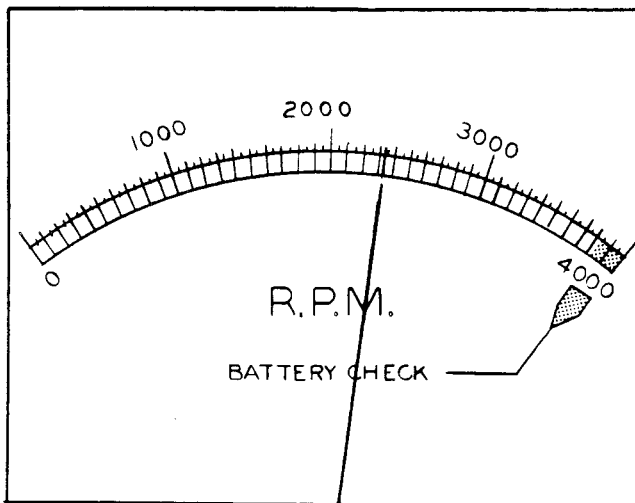

Plate 6683. Check NO-LOAD R.P.M.

4. Check engine for prescribed NO-LOAD 2350 R.P.M.

5. Check engine for prescribed 2200 R.P.M. with rated load. This may be done by tilting the upright back and momentarily holding the tilt lever in the back position to load engine. Engine must be properly tuned before making transmission pressure and stall checks.

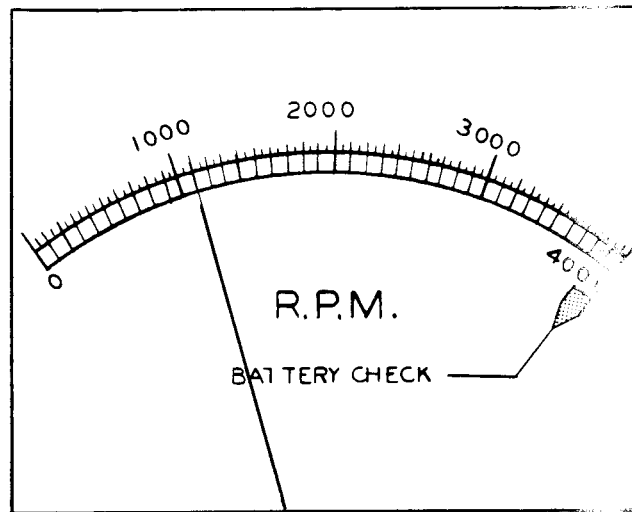
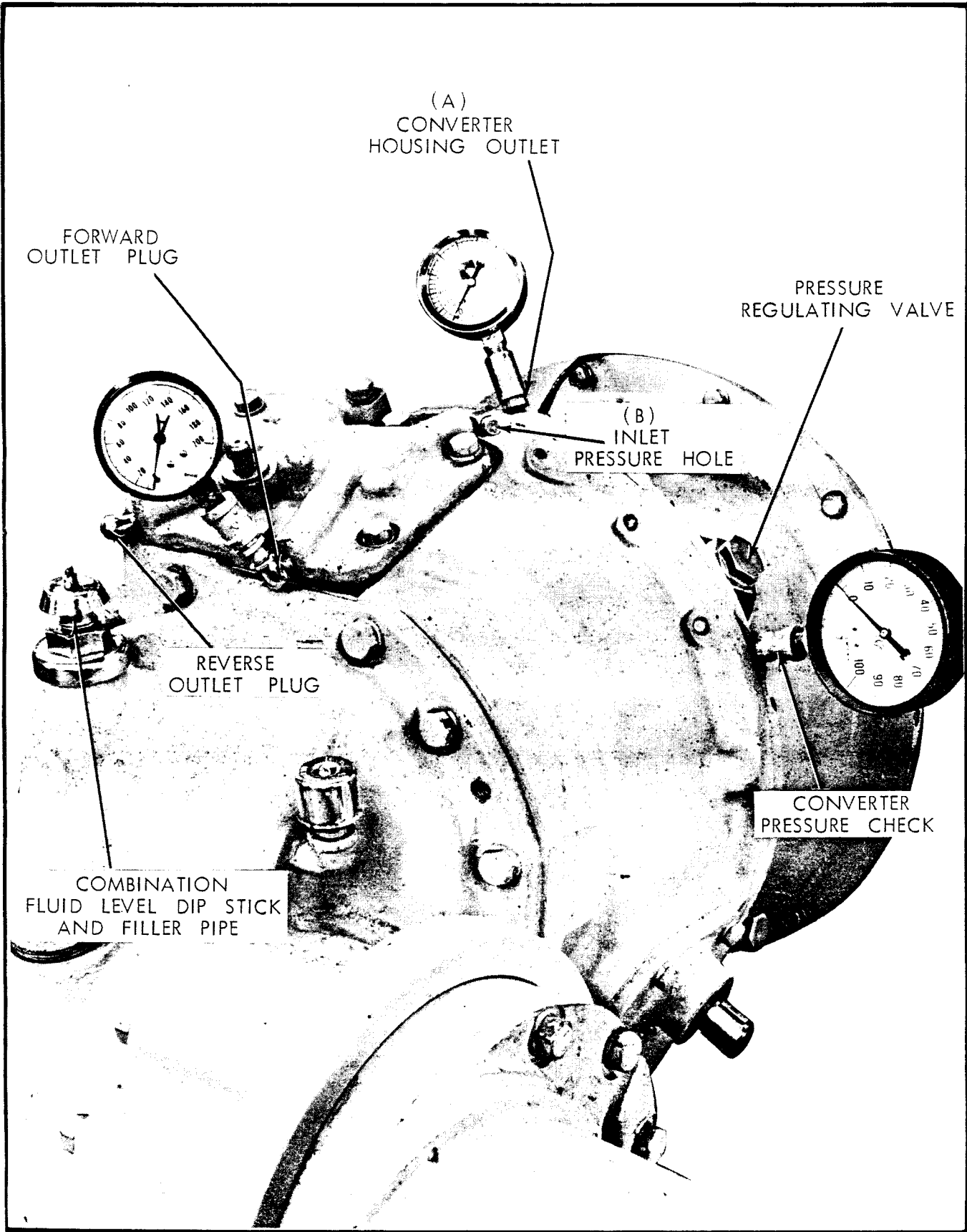

Plate 7763. Normal Engine Stall

6. With the machine parked in an uncongested area, check for normal engine stall. Place a capacity load on the forks and apply the parking brake. The driver's seat must be occupied so that in the event of parking brake failure the service brakes can be applied to prevent movement of the machine. With the machine in gear, accelerate to full throttle position. The normal engine stall R.P.M. is 1000 to 1150.

C A U T I O N

PROLONGED STALLING OF THE CONVERTER CAN CAUSE INTERNAL DAMAGE TO THE CONVERTER. STALL CONVERTER ONLY LONG ENOUGH TO GET THE PEAK R.P.M. READING. (MAXIMUM 30 SECONDS).



(Figure 1704a.) Plate 6658. Transmission Pressure Checks

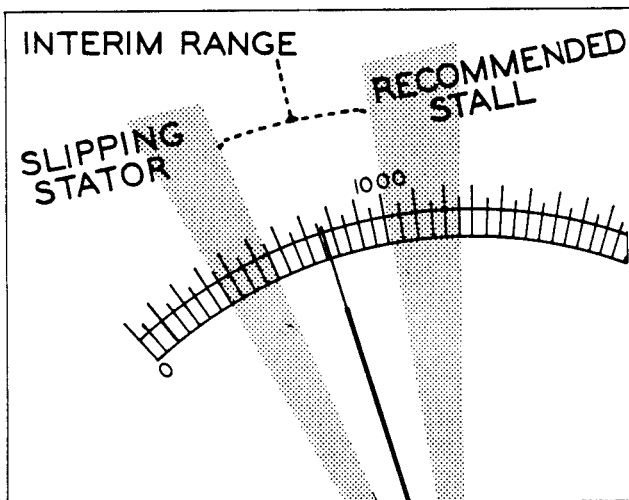

Plate 6685. Low INTERIM Stall

Low Interim Range Engine Stall (550 to 1000 R.P.M.) indicates a loss of engine power. If the engine stall speed falls within this range, corrections must be made to the engine to restore its power.

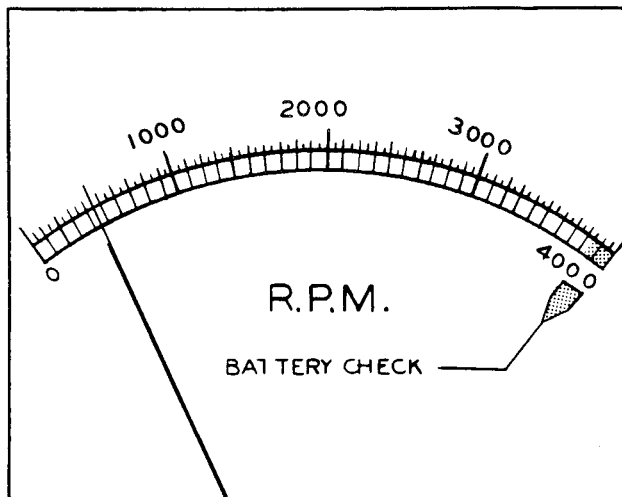

Plate 7765. Indication of Slipping Stator

Low Engine Stall (350 to 550 R.P.M.) indicates Converter Stator is slipping. Converter must be replaced. Report to designated person in authority.

7. Transmission Pressure Checks, see Plate 6658.

a. Remove pipe plug and install pressure gauge at the Converter Housing Outlet (A). Check Pump pressure with transmission in NEUTRAL and engine operating at 1400 R.P.M. Pressure should be 125 to 135 P.S.I. If pressure is low place a piece of shim stock (.001 to .002 thousandths thick and 1-1/2 inches wide) between the inlet pressure hole of the control cover and transmission case. If pressure remains low the trouble is in either the pressure regulating valve or the pump. If pressure returns to normal the trouble is in control cover. After completion of this test loosen the control cover and remove the shim stock. Tighten the cover retaining bolts and proceed to the following test.

b. Raise the machine so that the drive wheels clear the floor and place blocking of adequate strength to support the weight of the machine under the frame so it cannot accidentally become lowered during the forward and reverse selector pressure test. Install a pressure gauge at the forward outlet plug (see Plate 6658) and operate engine at 1400 R.P.M. with the transmission in forward gear. The pressure should be 125 to 135 P.S.I. If pressure is low loosen cover and place a piece of shim stock of the dimensions given in Step (a) between the control cover and transmission case in such a manner as to block the case hole leading to the forward selector. Tighten cover and check indicated pressure at 1400 R.P.M. If pressure remains low the trouble is in the control cover. If pressure has returned to normal the trouble is inside the transmission. The reverse selector may be checked in the same manner by moving the pressure gauge and shim stock to the reverse selector side of the control cover.

c. Check converter pressure by connecting a gauge to the converter housing at the location shown on Plate 6658. Pressure should be 65 to 75 P.S.I. at 2000 engine R.P.M.

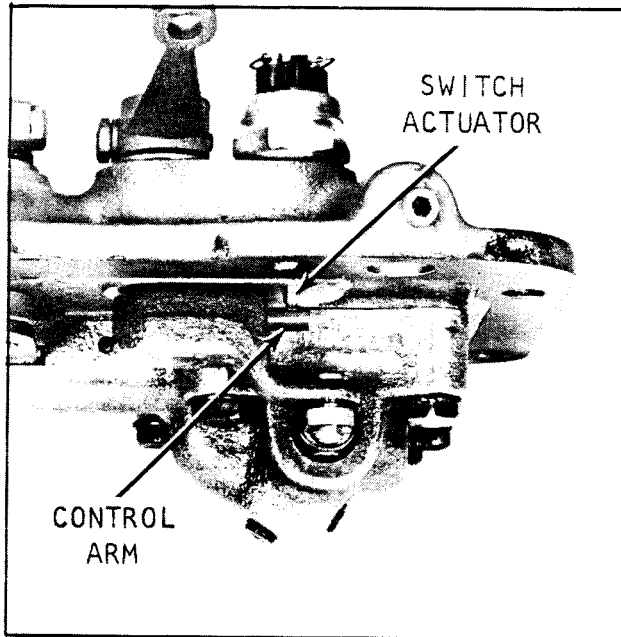

Figure 1793a. Starting Switch Actuated (NEUTRAL)

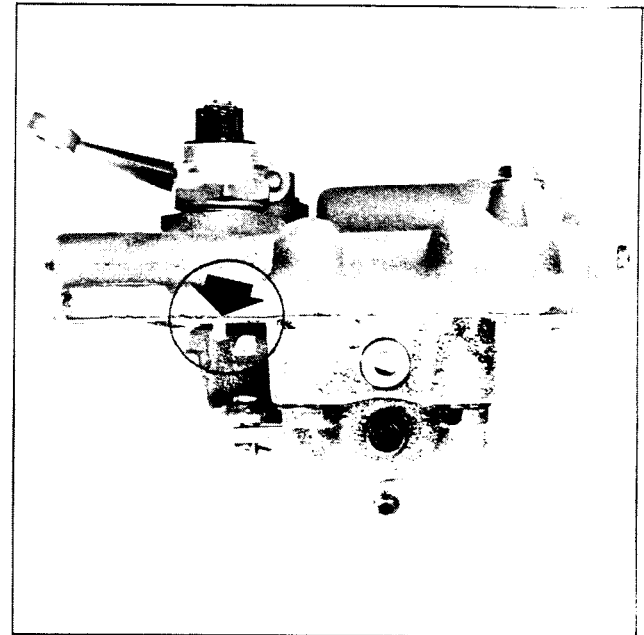

Figure 1793b. Starting Switch Unactuated (F or R)

NEUTRAL STARTING SWITCH

The neutral starting switch should be adjusted so that machine will not start except when the transmission control is in the (dead) neutral position.

ADJUSTMENT

1. With driver's seat occupied and transmission in gear hold starting switch in actuated position and gently move shift lever towards neutral position.

2. If engine does not start, repeat operation in opposite direction.

3. If engine starts, coming from either direction on the shift lever prior to reaching neutral, switch should be adjusted by means of shims underneath the switch until engine will not start unless it is in (dead) neutral; that is, vehicle will not move regardless of shift lever position during the starting cycle.

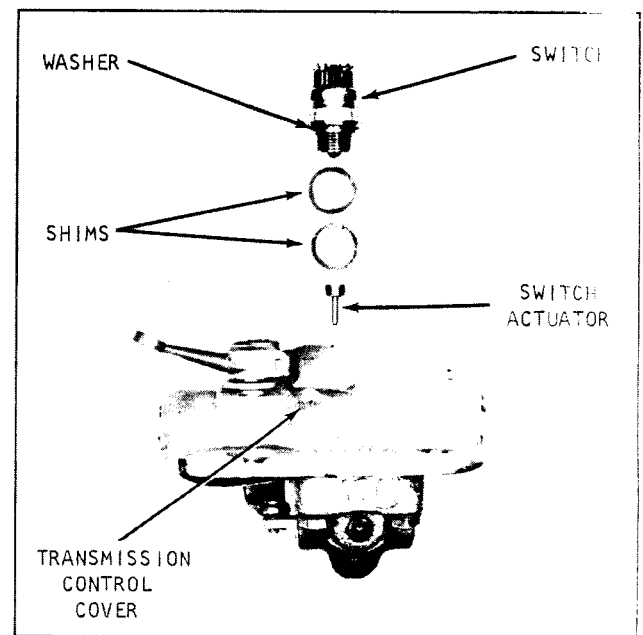

Figure 1793c. Neutral Starting Switch Adjustment

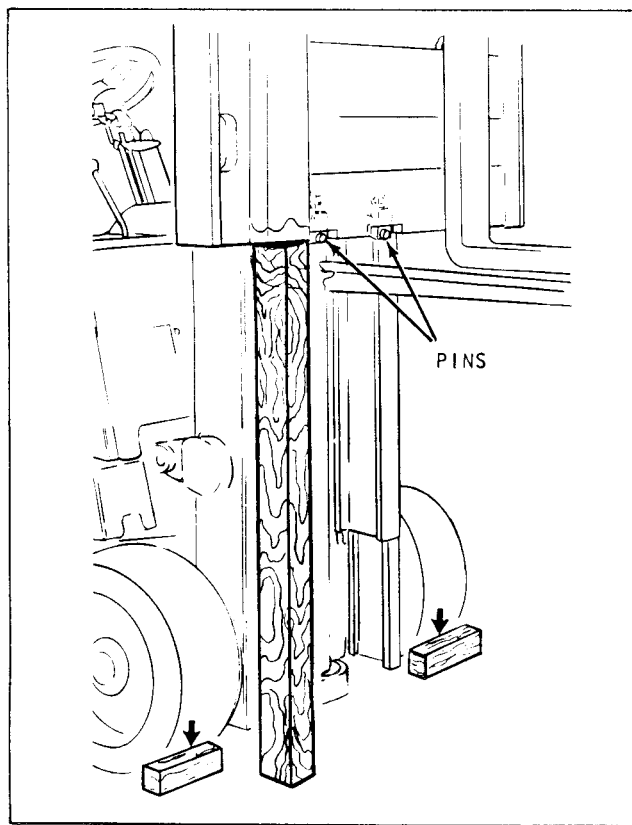

Plate 9593 Carriage Pin Replacement

Step 2. Remove anchor pins and replace with 3/8" x 2" bolts. FOR SAFETY REASONS, REMOVE ONLY ONE PIN AT A TIME. This will make pin removal easier when carriage is lowered.

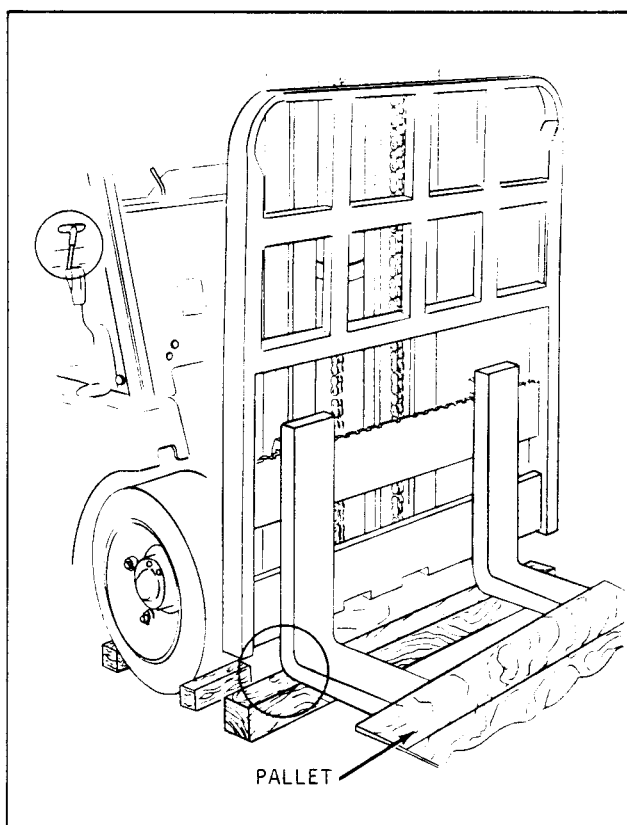

Plate 9560 Fork and Carriage Blocking

Step 3. Raise carriage off beam. Place beam on floor so, when lowered, the heel of the fork will rest on it as shown.

Step 4. Tilt upright full forward.

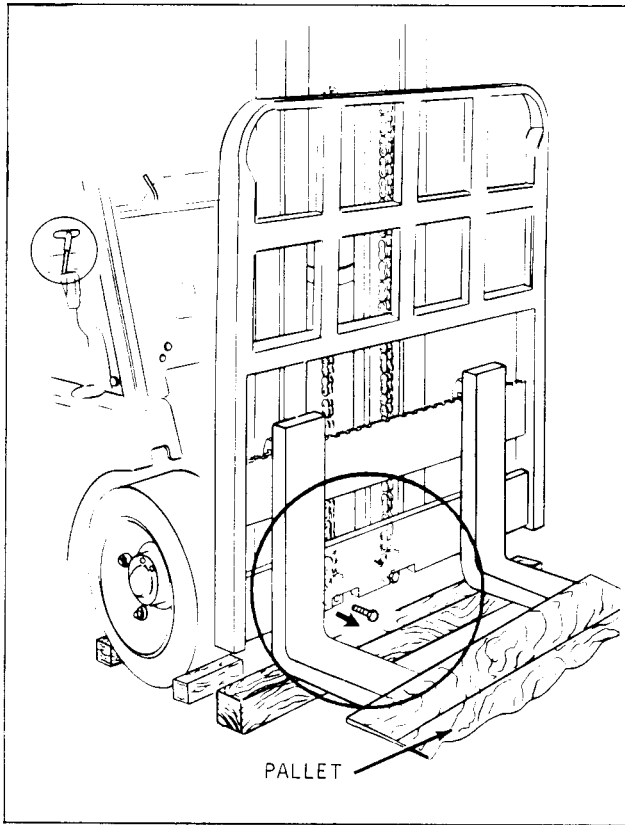

Plate 9561 Removing Bolts

Step 5. Remove 3/8" x 2" bolts. Place pallet on fork ends.

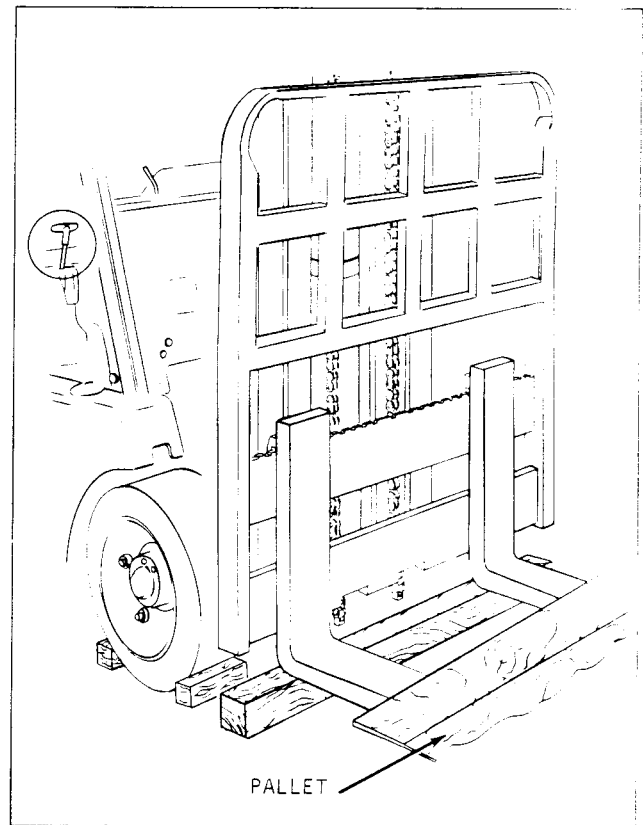

Plate 9562 Removing Chains From Anchors

Step 6. Pull chains out of carriage and brackets.

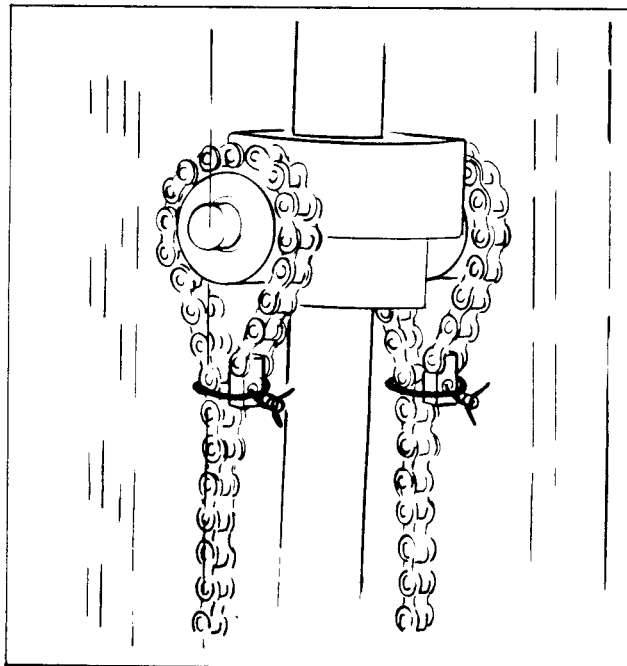

Plate 9563 Securing Chains (Typical)

Step 7. Wire chains around chain sheave as shown

N O T E

Use the same method on all cylinders.

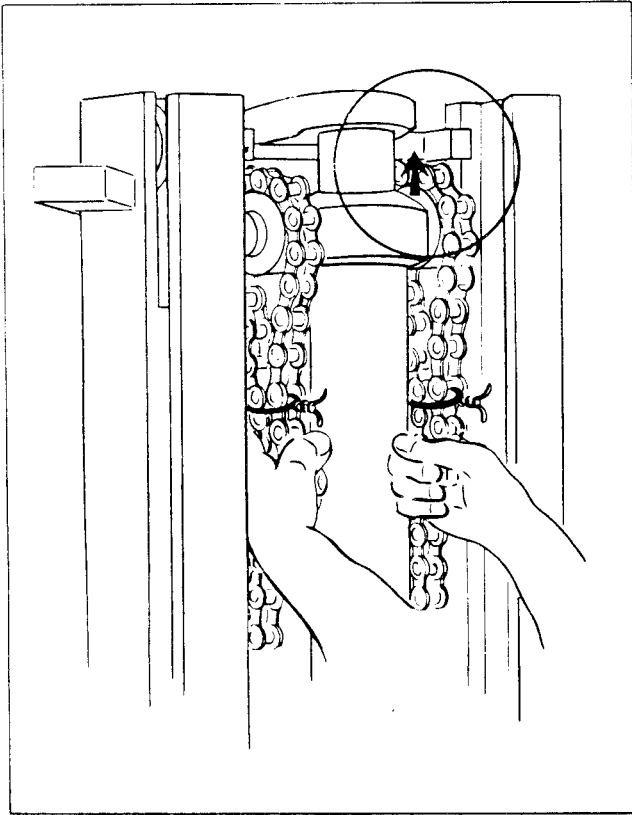

Plate 9564 Guiding Piston Head

Step 8. Guiding piston head with hands on chains raise piston to full up position.

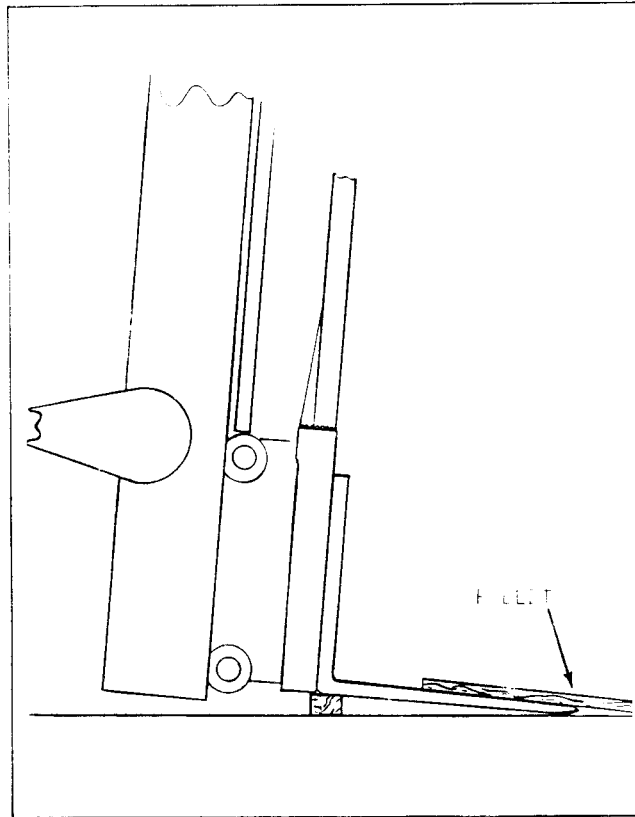

Plate 9565 Inner Rail Clearing Carriage Rollers

Step 9. Raise inner rail so it just clears upper carriage rollers. Leave upright at full forward tilt.

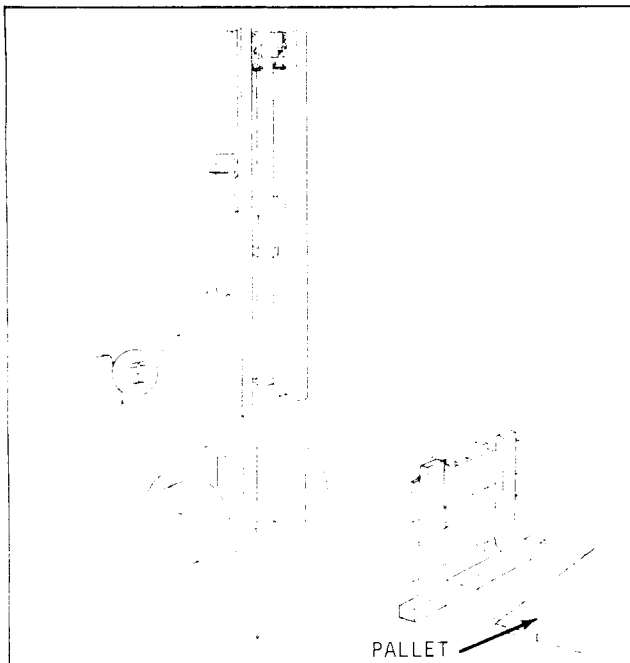

Plate 9566 Backing Machine Away From Carriage

Step 10. Remove blocks and release brake. Back machine away from carriage.

B. CARRIAGE ROLLER ADJUSTMENT

Plate 9567 Spanning Inner Rail

Step 1. Span inner rail with inside spanning tool to find the smallest distance between rails. Lock tool in position.

N O T E**FOR SIX ROLLER CARRIAGE ONLY**

After finding the smallest distance between rails, place a shim between the spanning tool and the inner rail, then lock spanning tool in position.

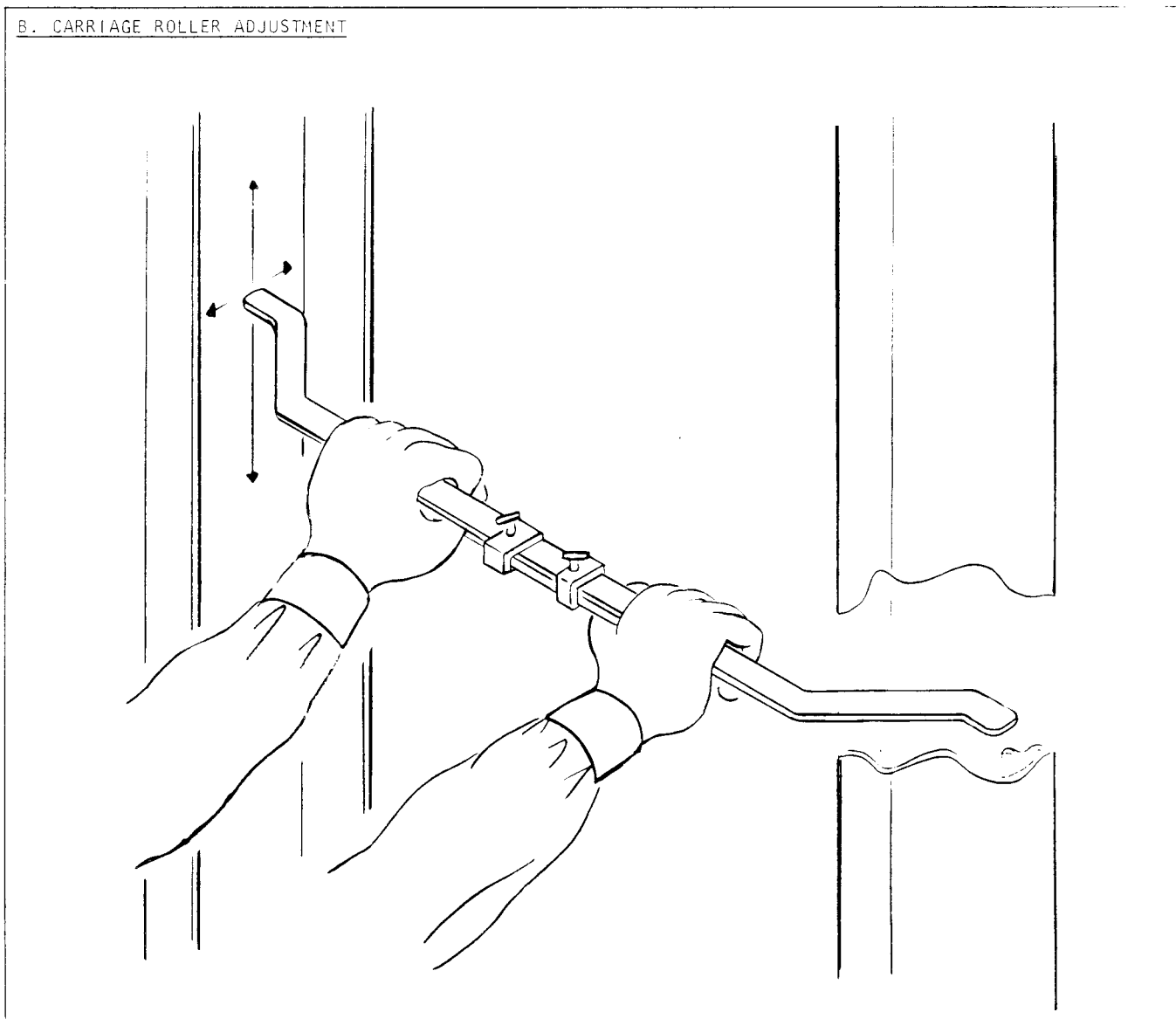
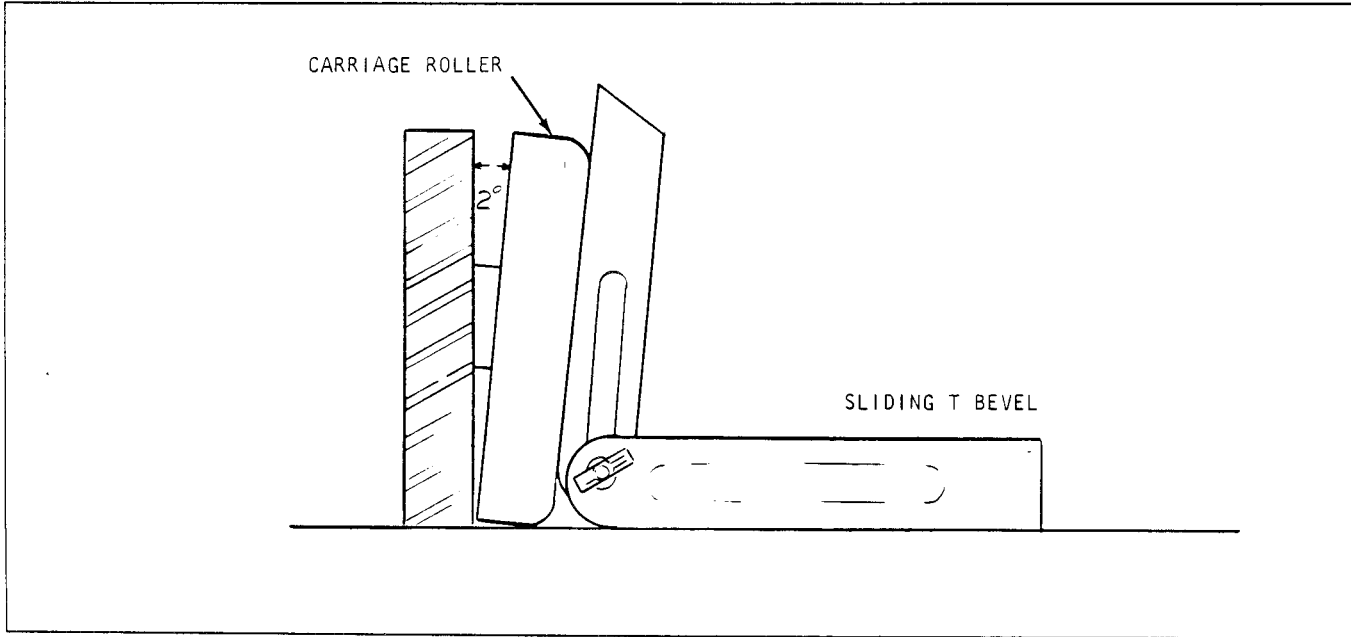

Plate 9589 Setting T Bevel

N O T E

Check angle of carriage rollers. Roller pin bosses are welded at $2^\circ \pm 1/2^\circ$ and if damaged, replace carriage roller pin boss assembly. To obtain this, contact Central Parts.

To check roller angle use a Sliding T Bevel and Protractor. Lay one side against roller surface and lock in place.

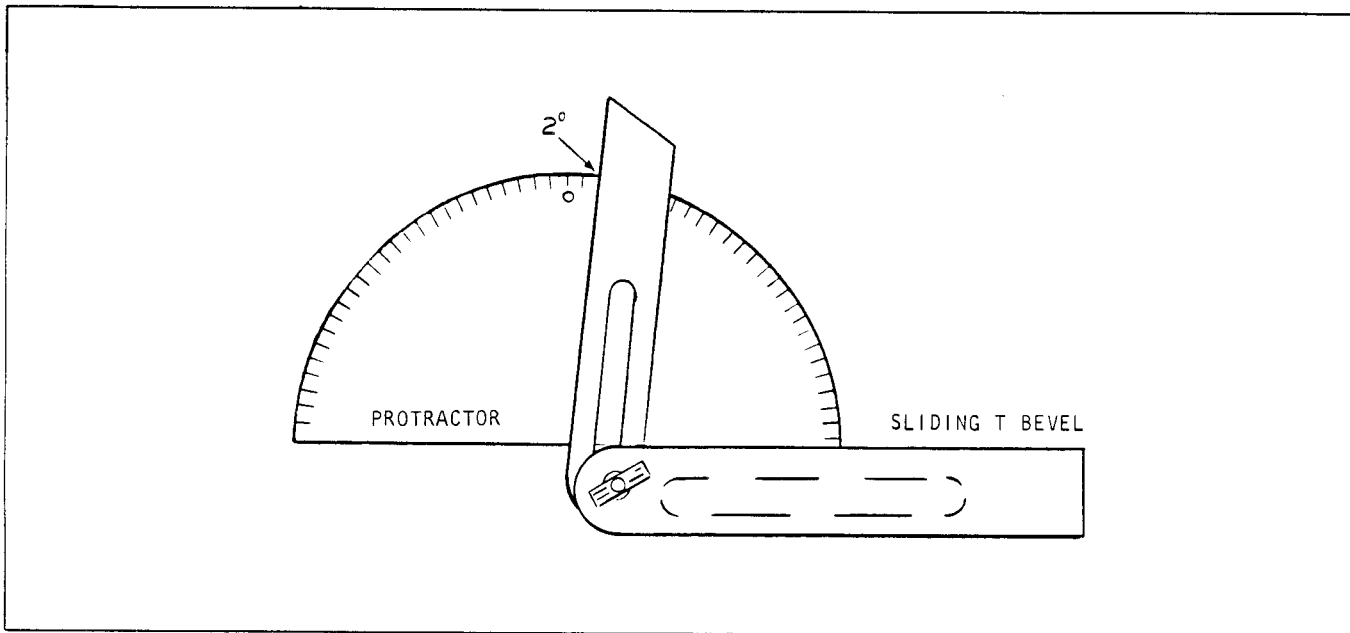

Plate 9590 Checking Roller Angle

Determine degree of angle by placing Protractor on Sliding T Bevel.

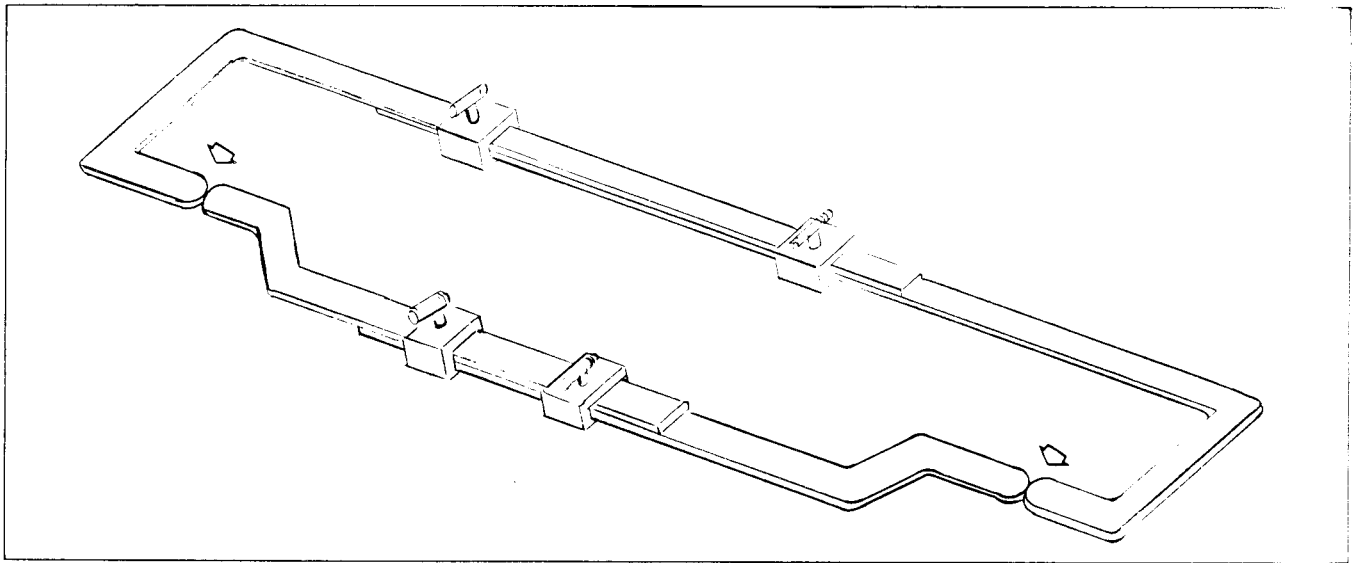

Plate 9568 Setting Outside Spanning Tool

Step 2. Set outside spanning tool to match inside spanning tool. Lock tool in position.

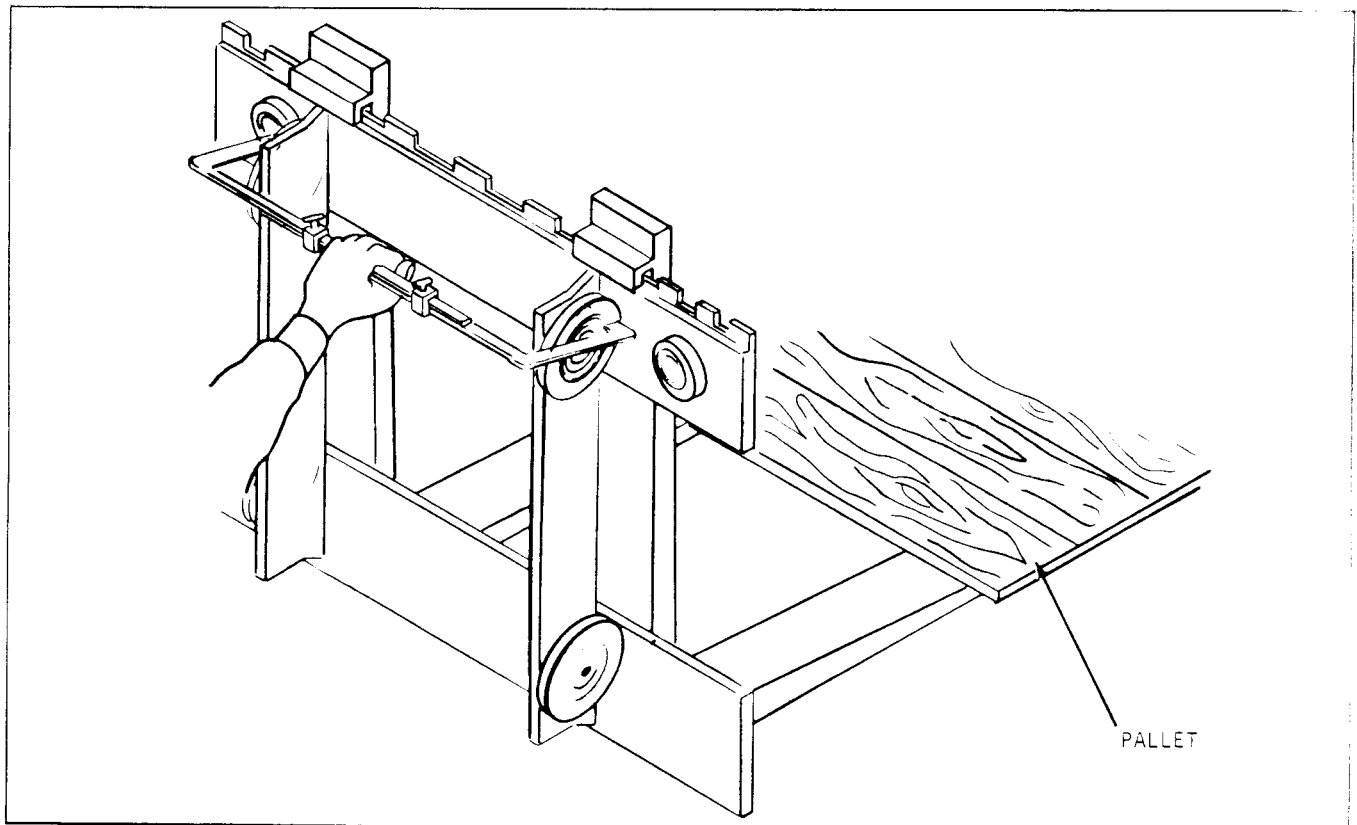

Plate 9569 Spanning Upper Rollers (Four Roller Carriage)

Step 3. Span upper carriage rollers at their outer most camber point. Add or subtract ...

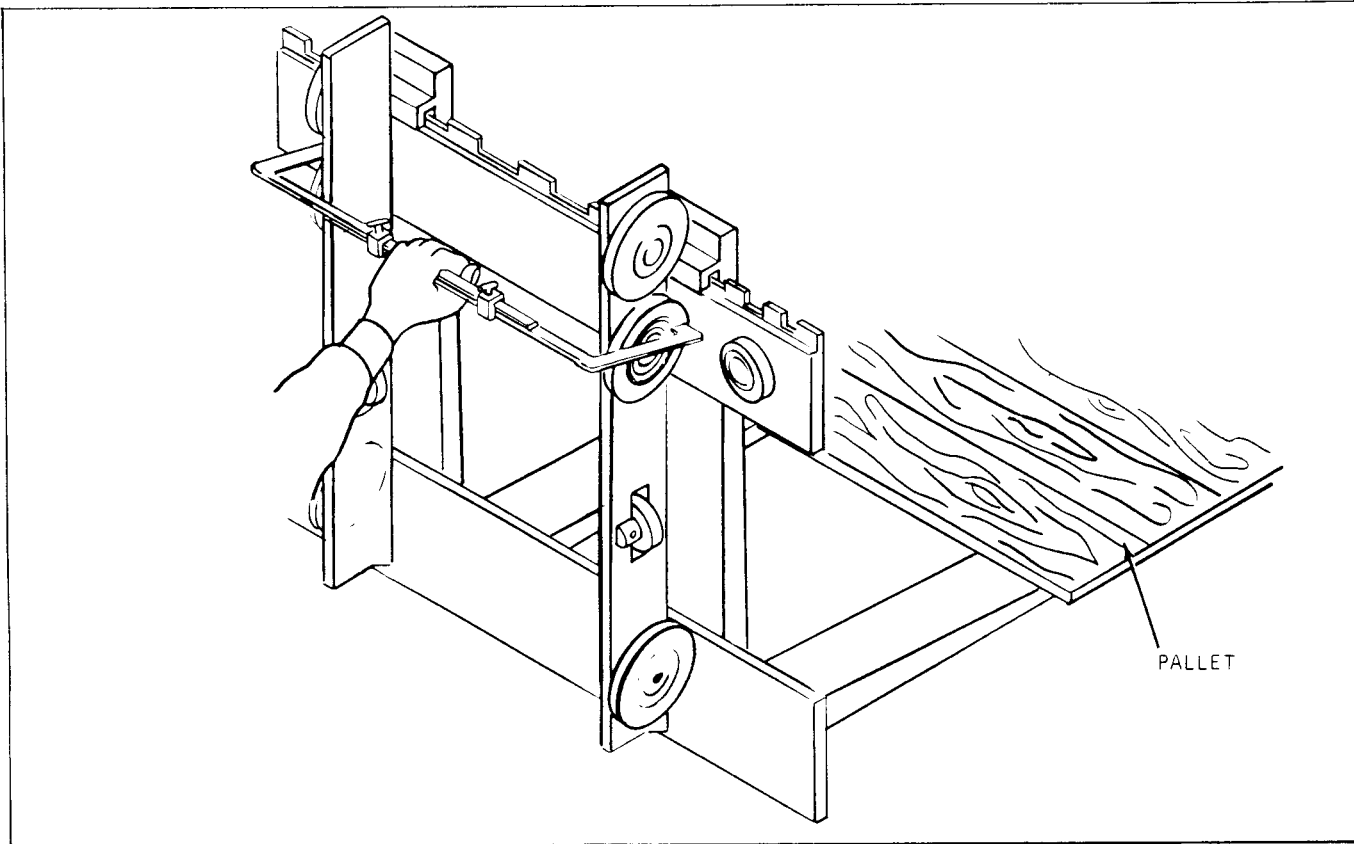

Plate 9570 Spanning Upper Rollers (Six Roller Carriage)

...shims at roller shaft to reach tool size.

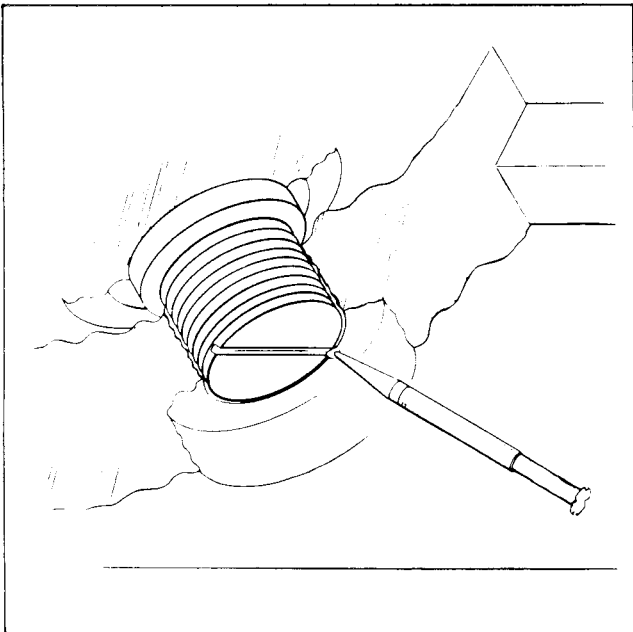

Plate 9571 Securing Outer Thrust Roller

NOTE

Before centering carriage rollers check outer thrust rollers for security and condition of bearings. If loose tighten and stake. If worn replace.

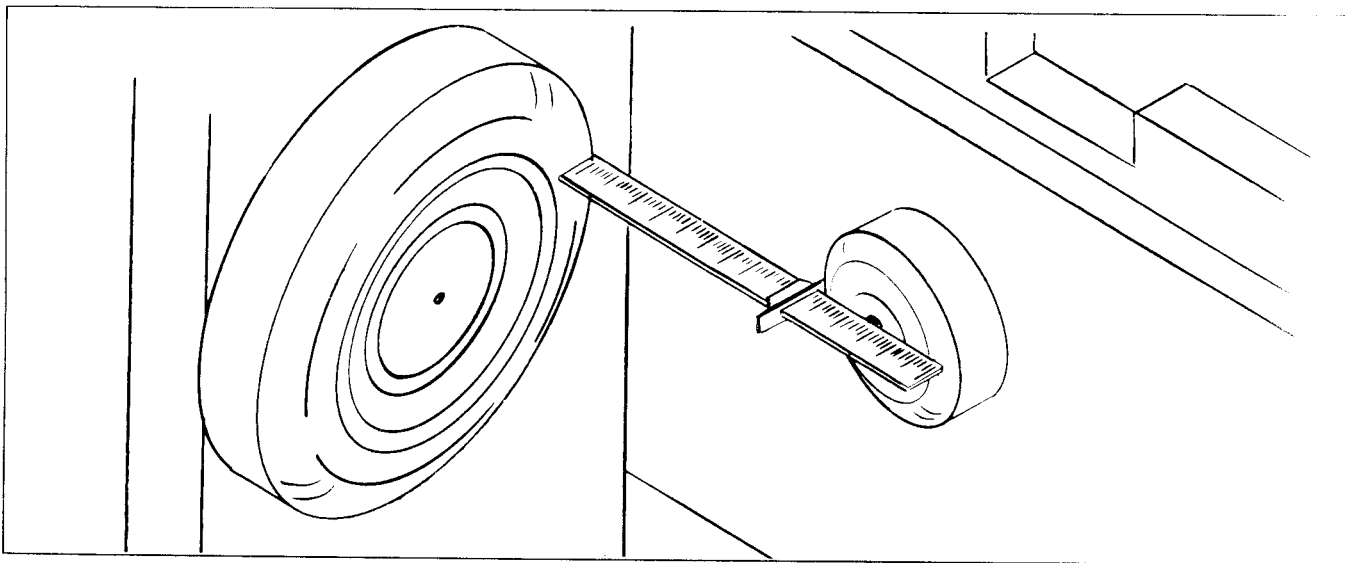

Plate 9572 Centering Carriage Rollers

Step 4. Center carriage rollers within outer thrust rollers by placing 6" scale on the carriage roller surface and measuring the distance to the outer thrust roller face. Add or subtract shims to one roller to the other to make measurement equal.

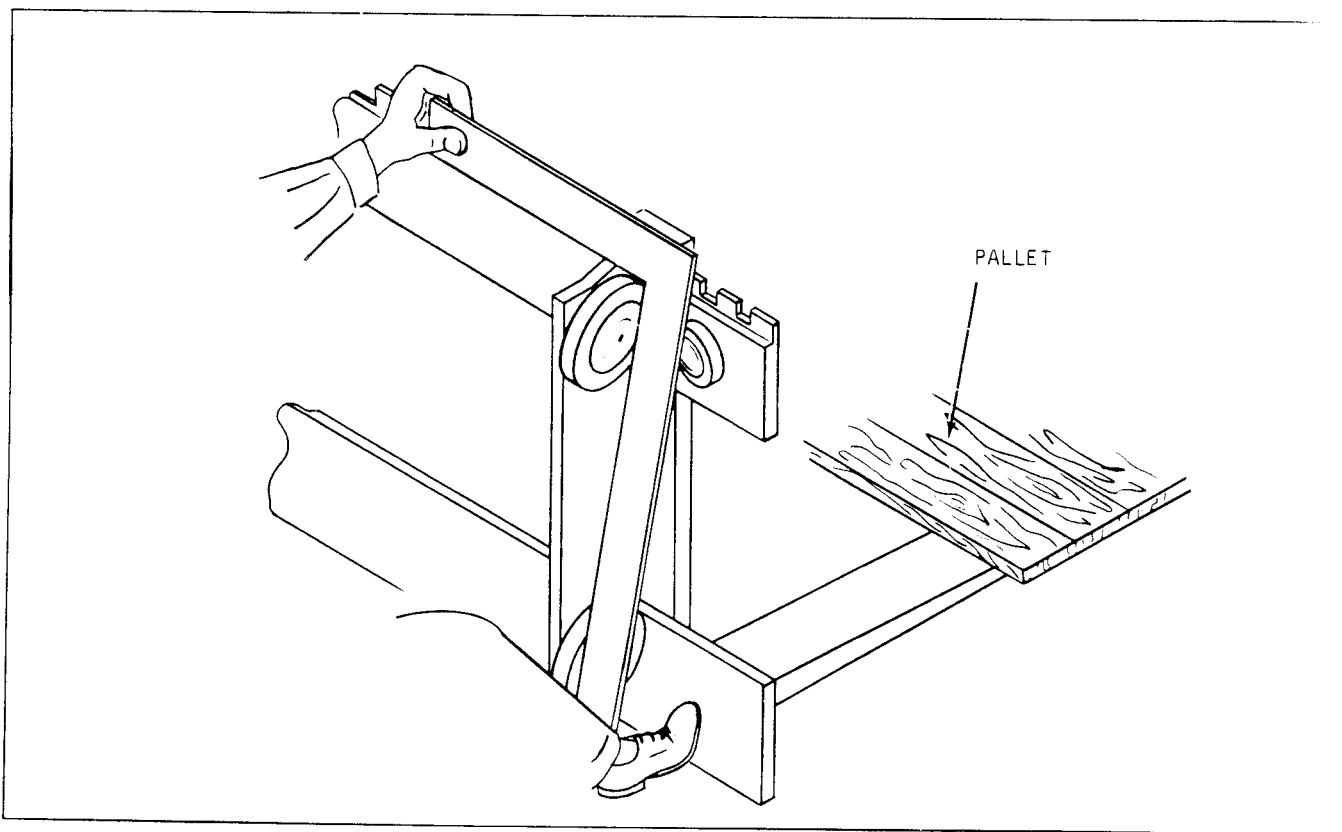

Plate 9573 Squaring Carriage Rollers (Four Roller Carriage)

Step 5. Square carriage rollers by placing carpenter's square at the outer most camber of the ...

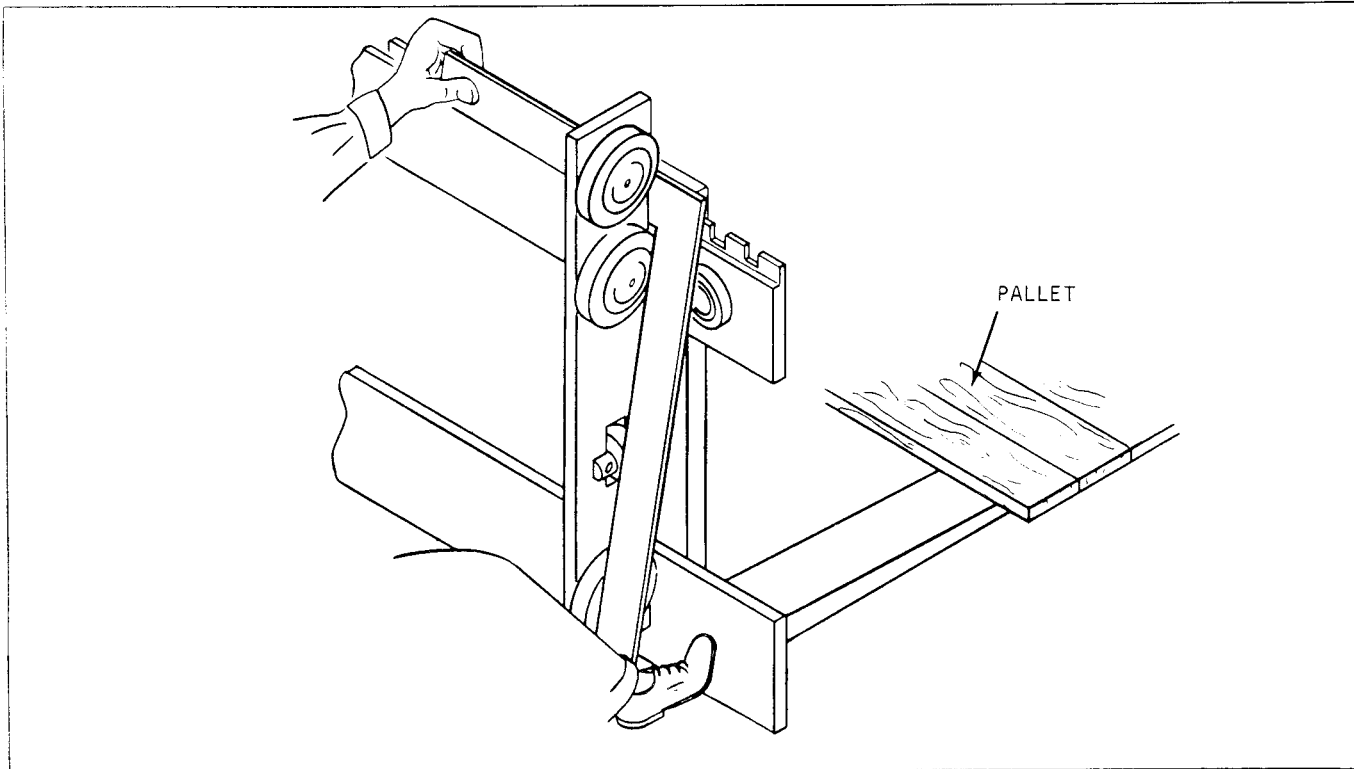
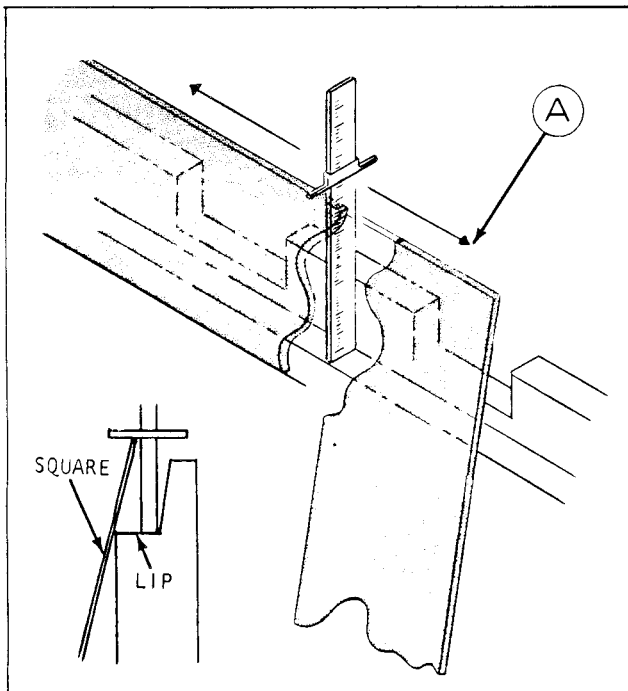

Plate 9574 Squaring Carriage Rollers (Six Roller Carriage)

... upper and lower rollers. Hold square in place with ankle and hand as shown.



Step 6. Hold square and measure the distance between the top face (or lip) of the upper fork bar to the edge of the square at Point A. Now take a measurement at opposite end of square these measurements should be the same. If they are not, add or remove shims on lower roller shaft until distance measured at each end is equal.

Plate 9575 Measuring For Squareness

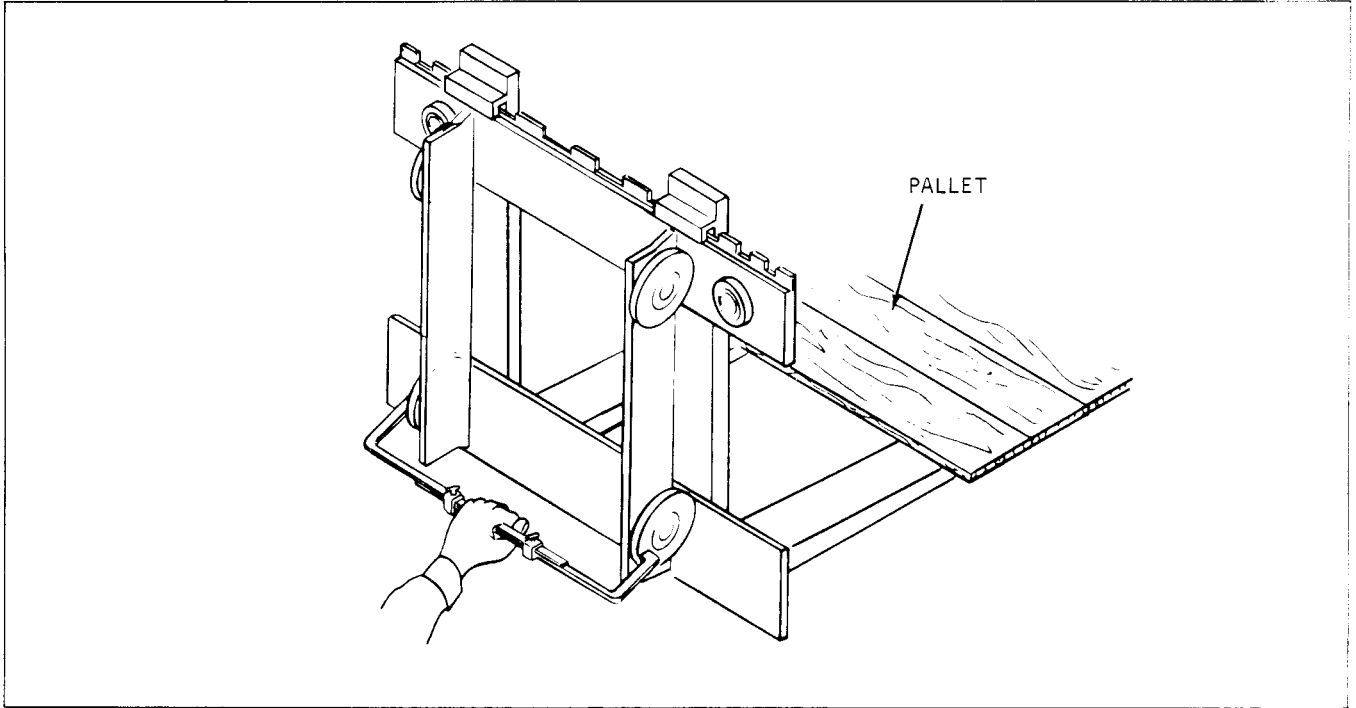

Plate 9576 Spanning Lower Rollers (Four Roller Carriage)

Step 7. Span lower rollers. Add or subtract shims to (the roller that has not been squared) ...

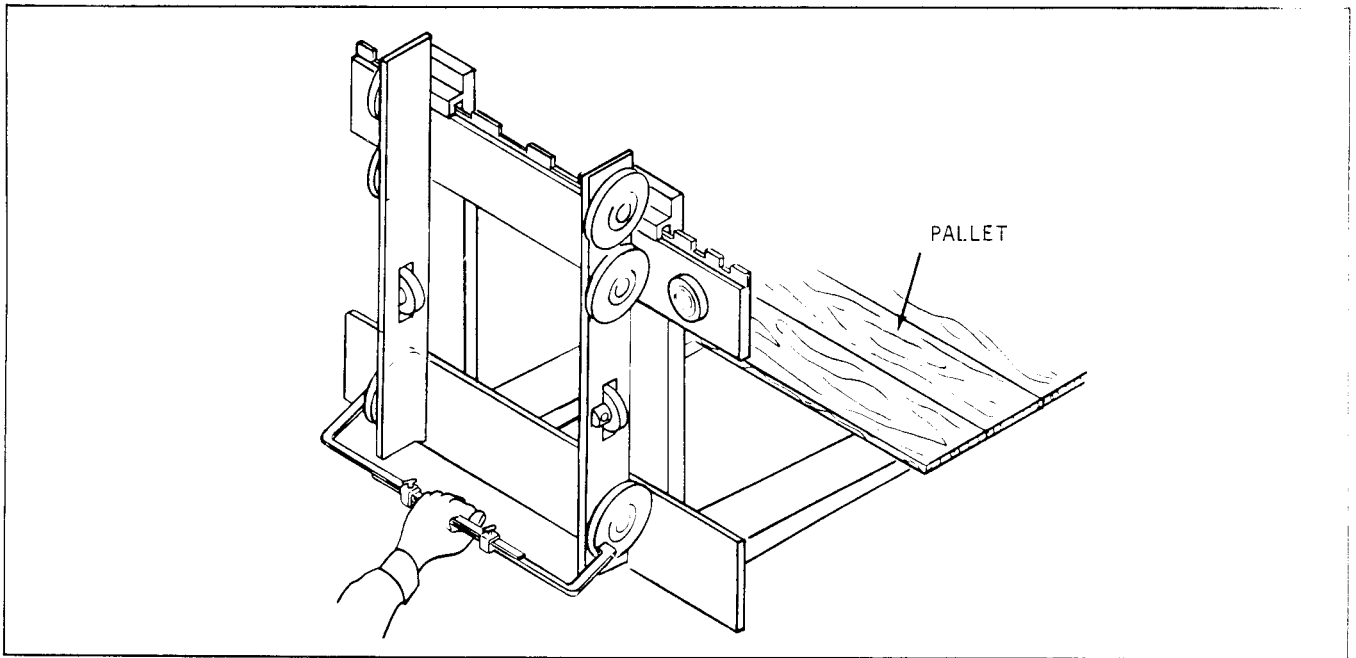

Plate 9577 Spanning Lower Rollers (Six Roller Carriage)

... reach the size of the outside spanning tool.

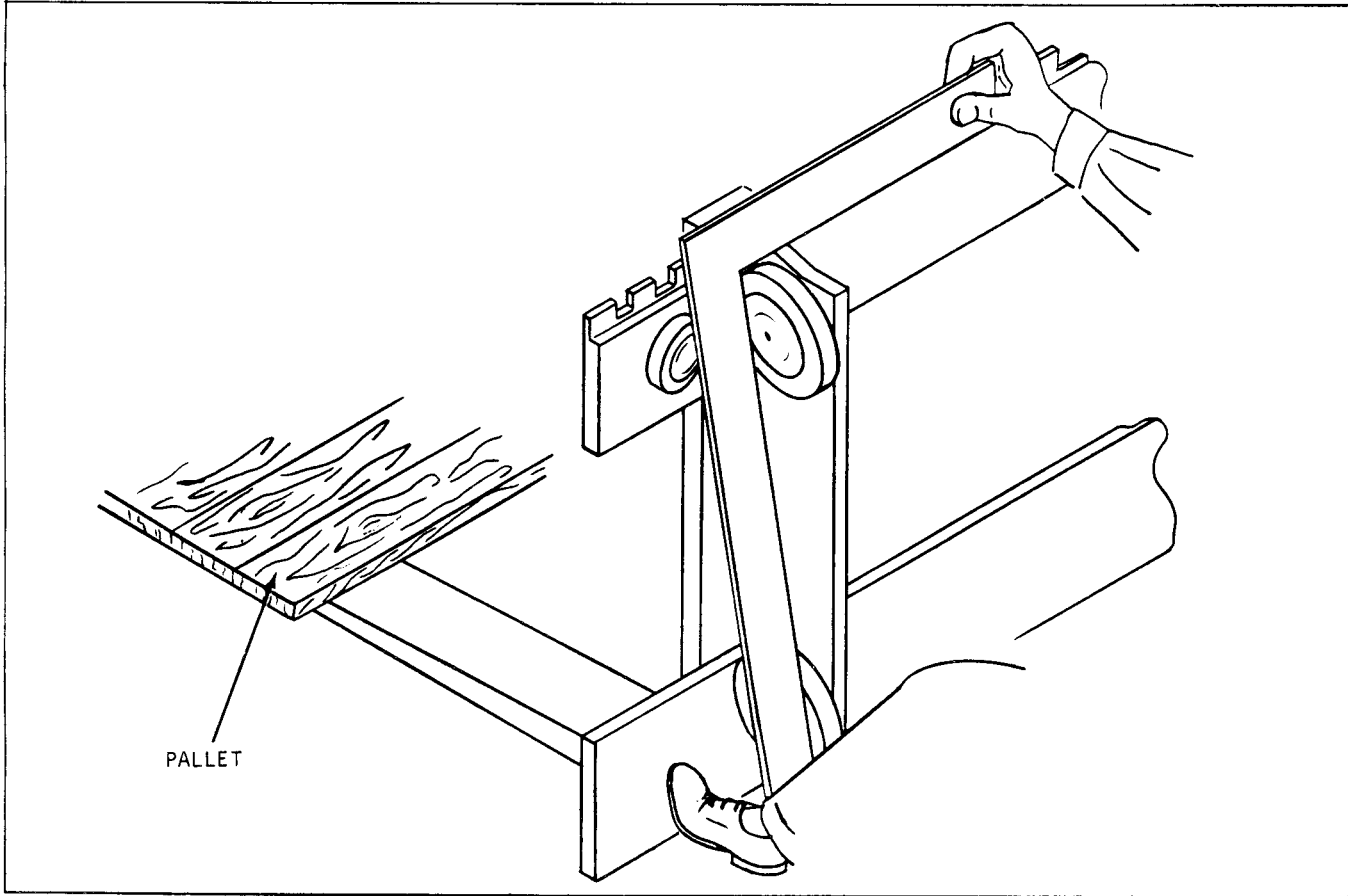

Plate 9578 Checking Squareness (Four Roller Carriage)

Step 8. Check opposite side for squareness (by holding square in the same manner as before and checking ...

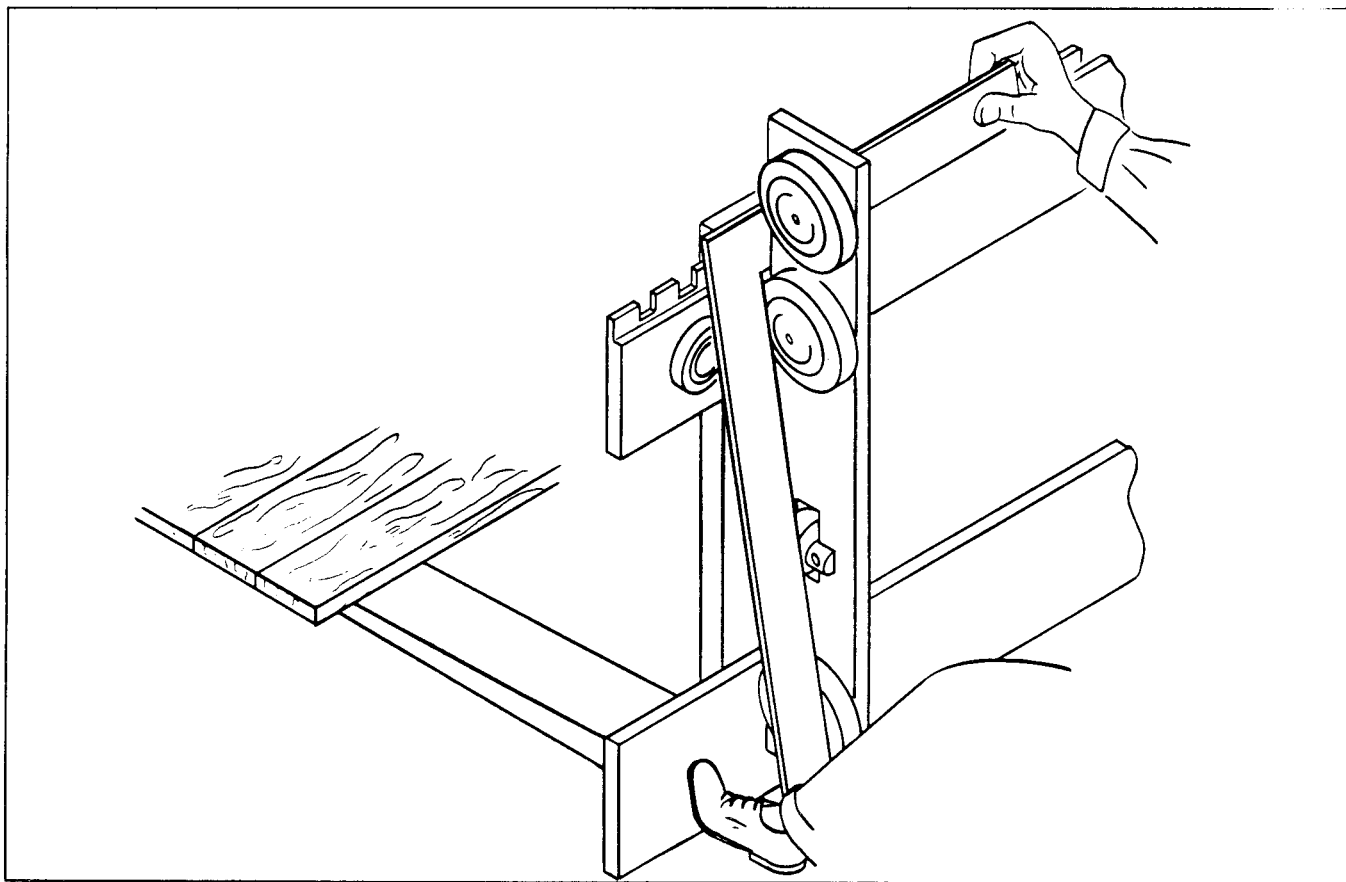

Plate 9579 Checking Squareness (Six Roller Carriage)

... measurement). This side will be square within $1/32''$; if not, return to Step 5. and repeat procedure.

SIX ROLLER CARRIAGE ONLY

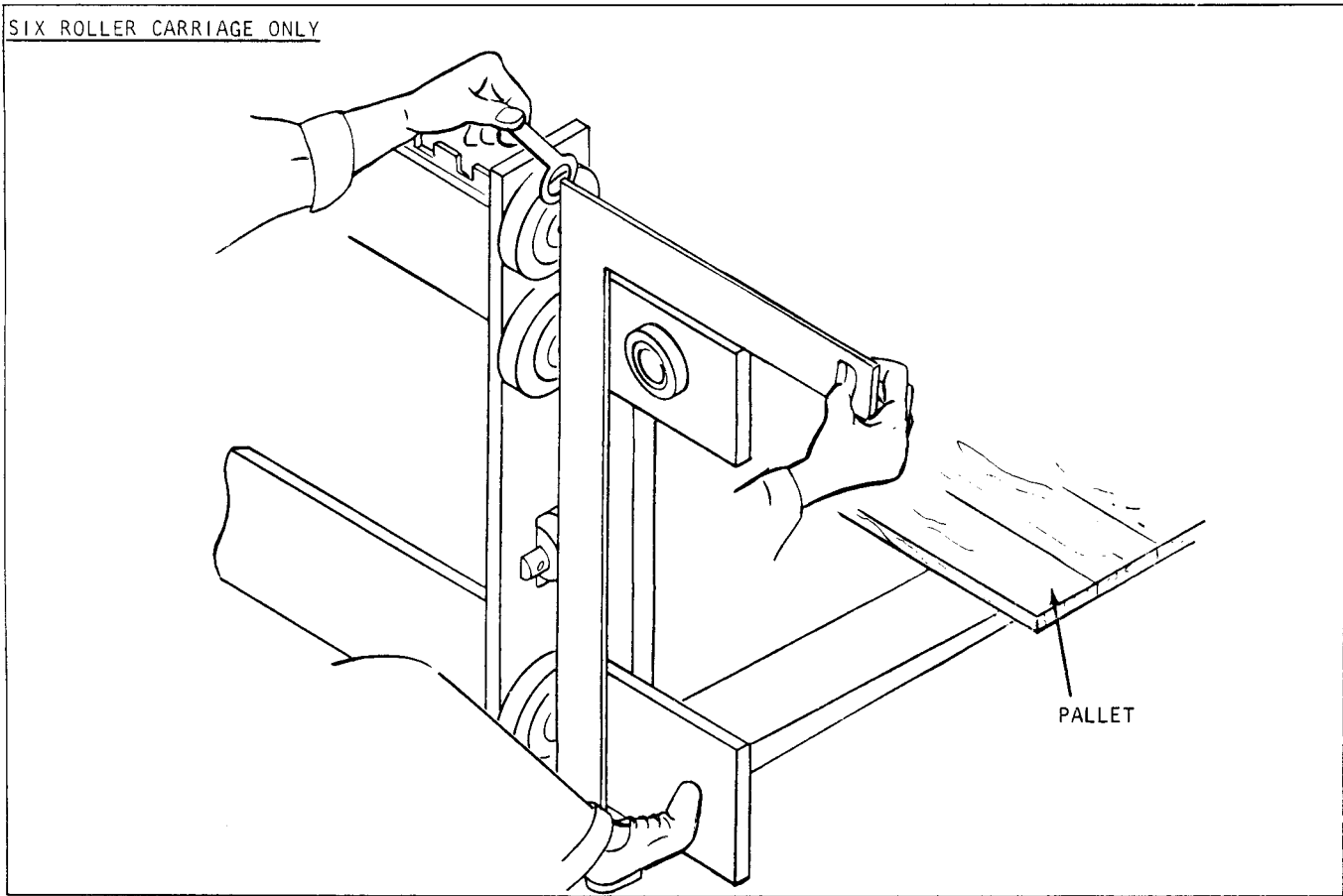

Plate 9580 Top Roller Clearance

Step 1. Place square on the vertical center line of the carriage rollers, as shown above. There must be some clearance between the square and the side surface of the top roller. This clearance should not exceed 1/32" or one shim

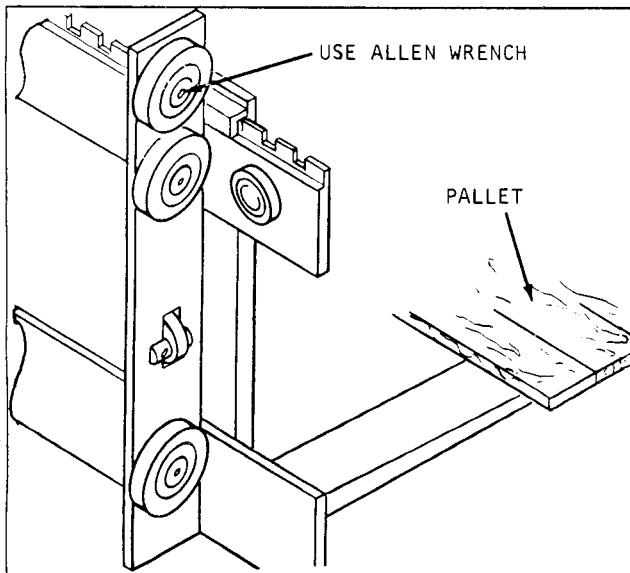

Plate 9581 Removing Top Roller

Step 2. If adjustment is necessary, remove allen screw, lock washer and flat washer to add or remove shims on shaft. Tighten screw securely after completing adjustment.

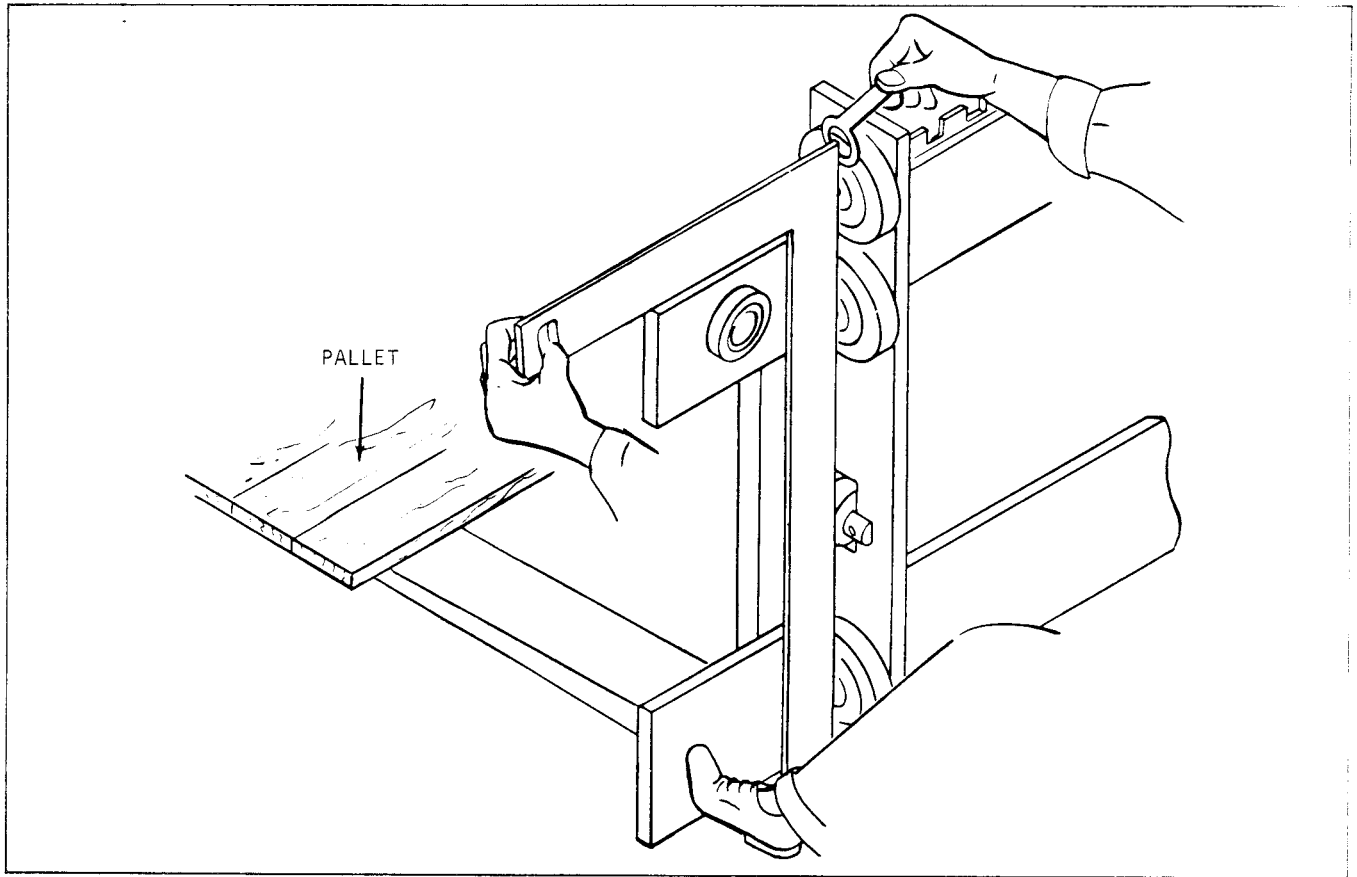

Plate 9582 Top Roller Clearance

Step 3. Check opposite upper roller in the same manner; adjust if necessary.

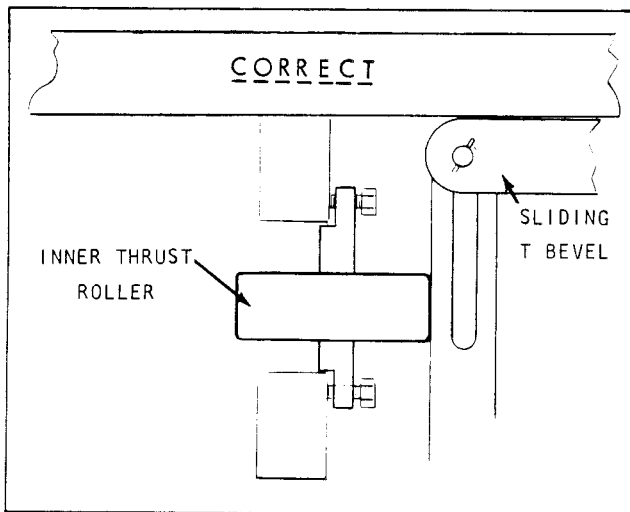

Plate 9583 Checking Squareness ■ CORRECT

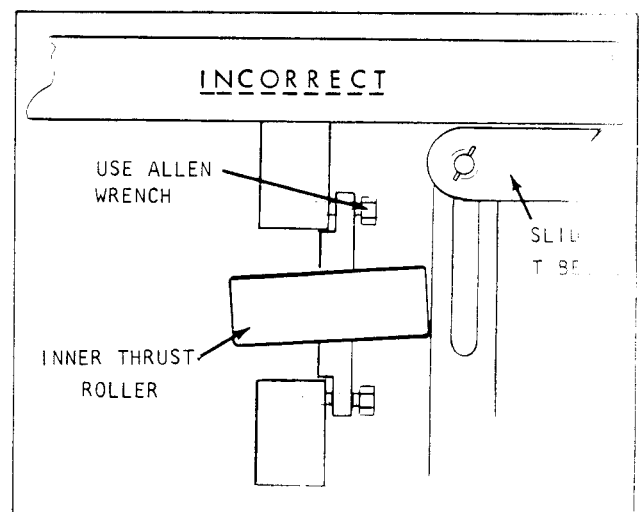

Plate 9584 Checking Squareness ■ INCORRECT

Step 4. Check squareness of inner thrust rollers with Sliding T Bevel. Set Sliding T Bevel to 90° using carpenter's square.

Step 5. Add or subtract shims for adjustment (Use allen wrench see Plate 9584).

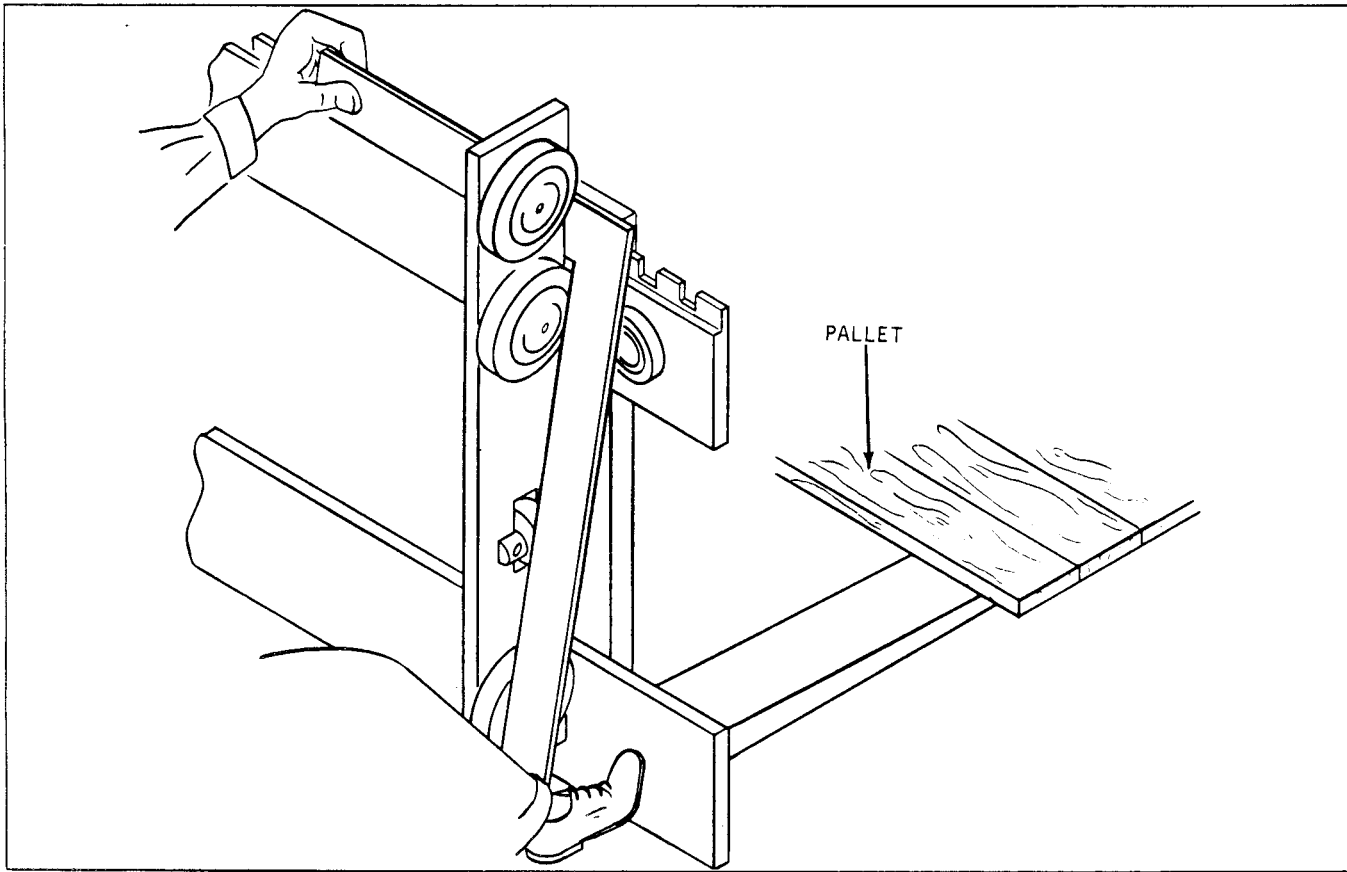

Plate 9574 Square And Side Thrust Roller

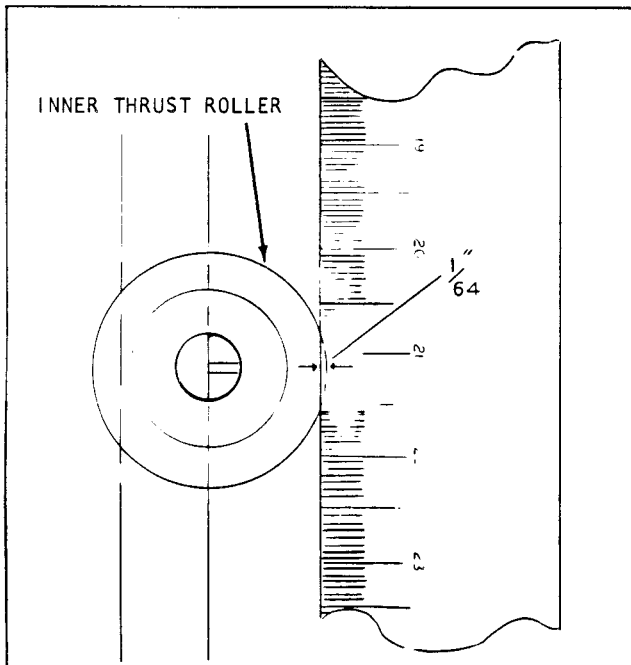

Plate 9585 Reading Roller Projection

Step 6. The inner thrust roller is to project $\frac{1}{64}$ " past line of square. Use one thrust roller shim and eyeball distance as shown (Plate 9573 and Plate 9585).

Step 7. Repeat Step 6. on opposite side.

C. CARRIAGE INSTALLATION

N O T E

Before installing carriage, check upright for proper shimming adjustment.

Step 1. Drive machine up to carriage and position upright to match tilt of carriage.

Step 2. Raise inner rails to just clear upper carriage rollers.

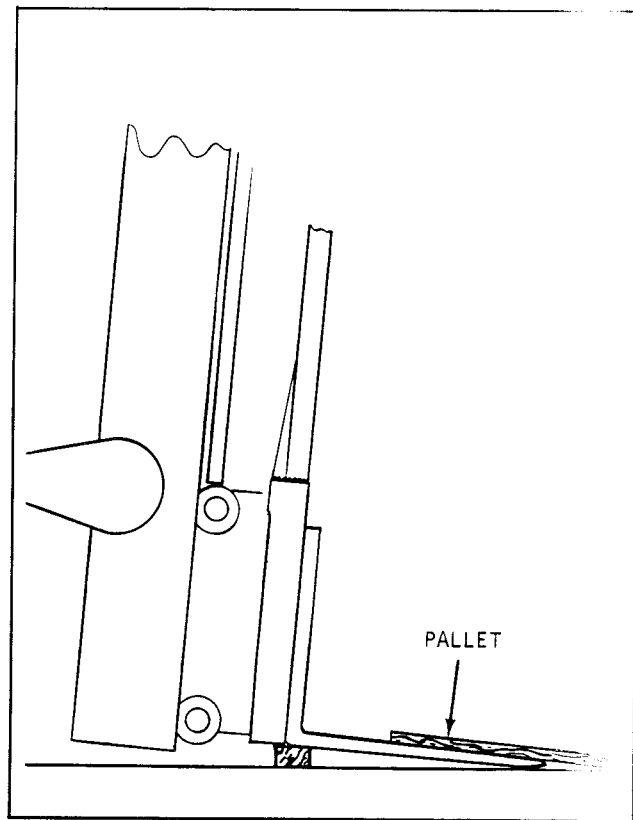

Plate 9565 Inner Rail Clearing Carriage Rollers

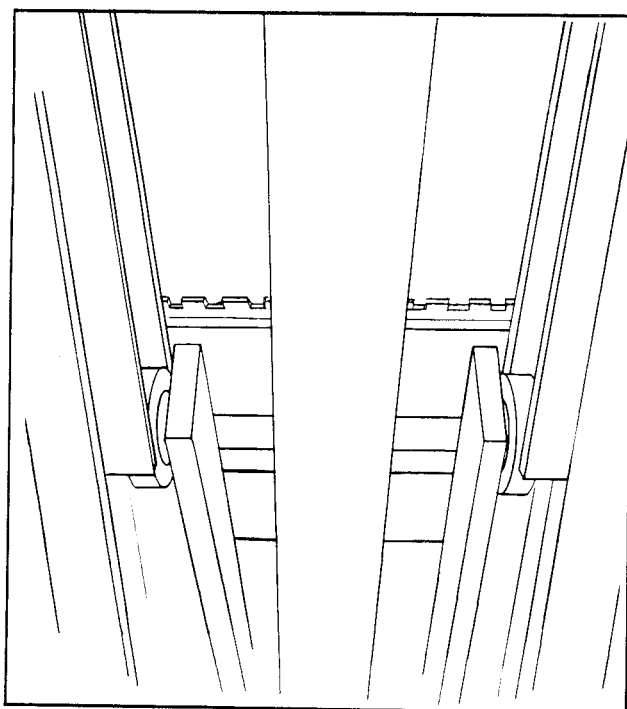

Plate 9591 Rollers Guiding Into Inner Rail

Step 3. Continue to drive machine forward until inner rails line up with upper carriage rollers, then... slowly lower inner rails to full down position.

CAUTION

CHECK TO BE SURE THE TOP CARRIAGE ROLLERS ARE GUIDING INTO INNER RAIL.

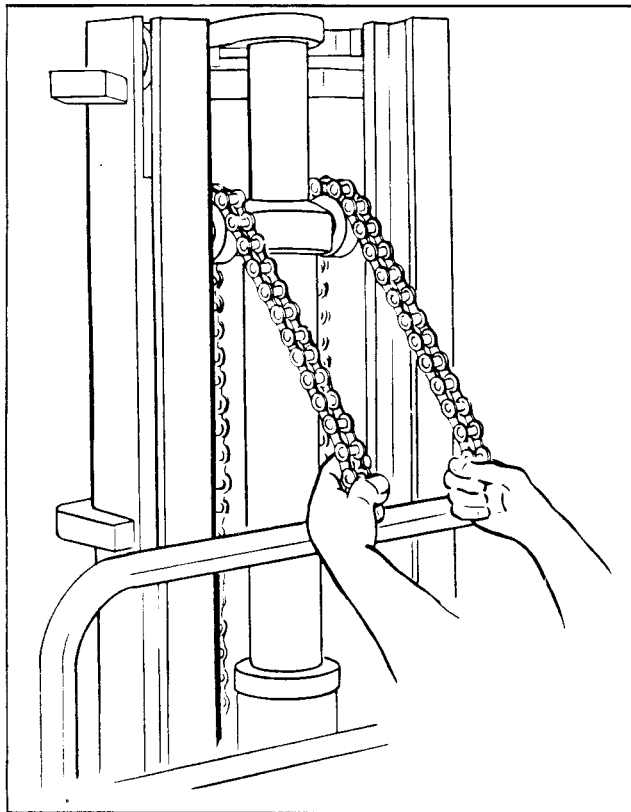

Plate 9586 Pulling Piston Head Down

Step 3(a). Remove wires holding lift chains.

(b). With a chain in each hand and someone holding the lift cylinder lever down, pull the piston to full down position. Place chains behind carriage.

Step 5. Raise carriage about 5' and place a 3' to 4' long 4"x4" wooden beam under it. DO NOT stand directly under forks. Lower carriage onto beam.

Step 6. Replace bolts with anchor pins.

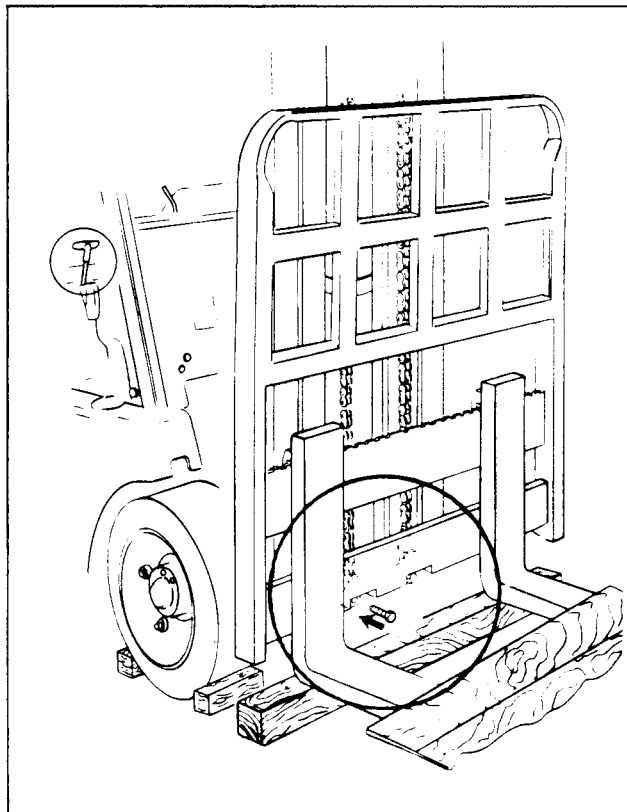

Plate 9587 Installing Bolts

Step 4. Put chain anchors in carriage anchor brackets and install 3/8" x 2" bolts in anchor pin holes.

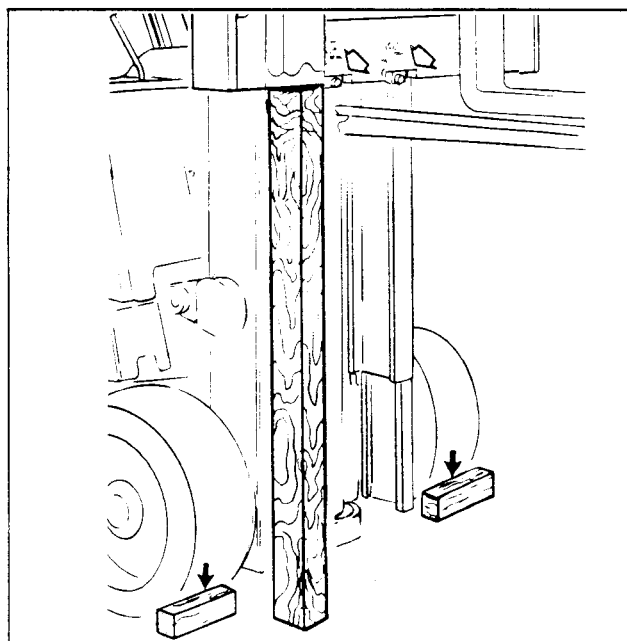

Plate 9593 Carriage Pin Replacement

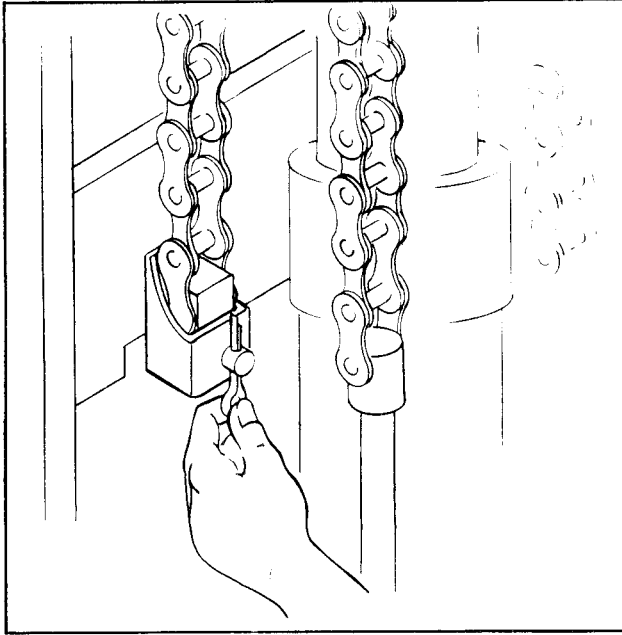
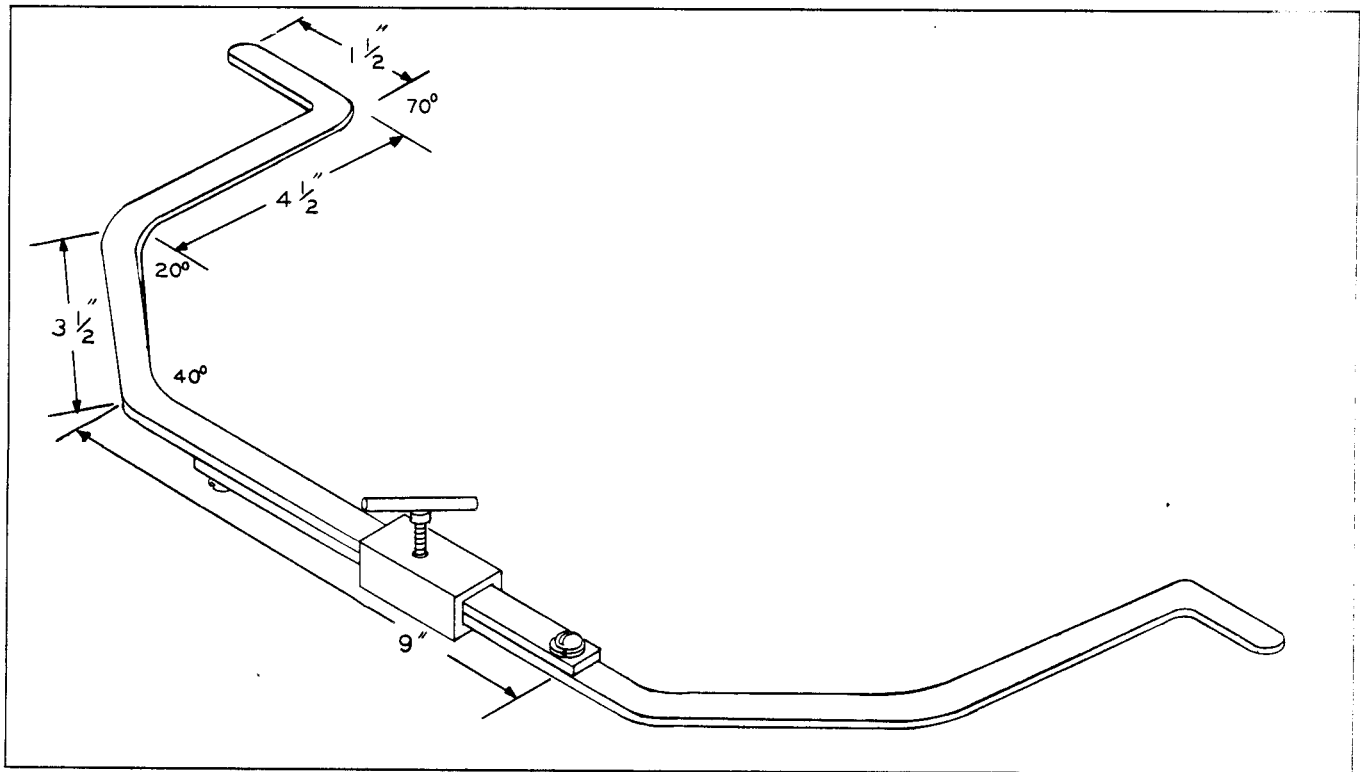

Plate 9588 Installing Cotter Pins

Step 7. Replace cotter pins in anchor pins.

Step 8. Raise and lower carriage to full positions checking all phases of operation.



INSIDE SPANNING TOOL

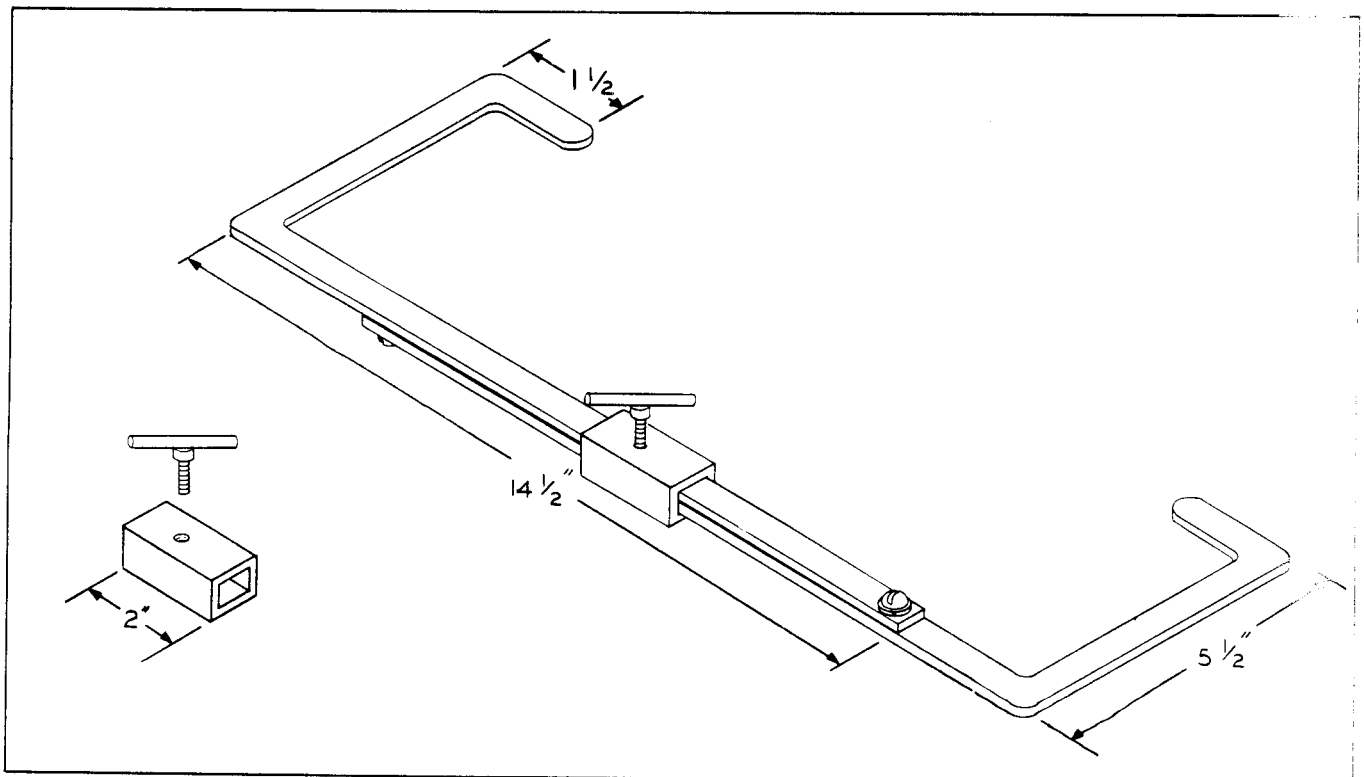

OUTSIDE SPANNING TOOL

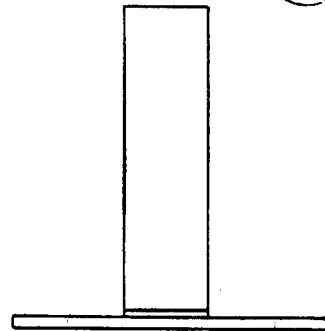
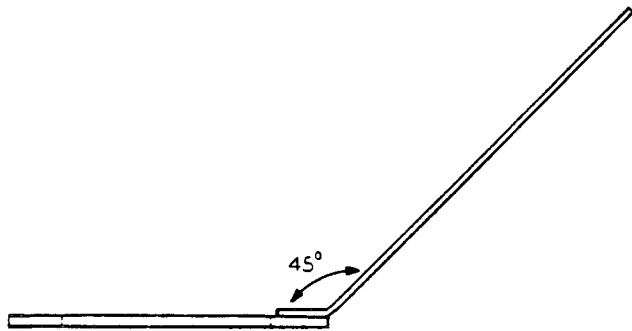
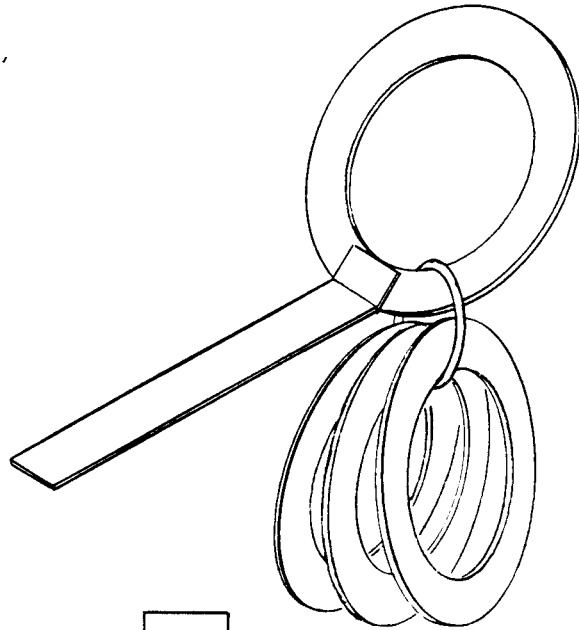
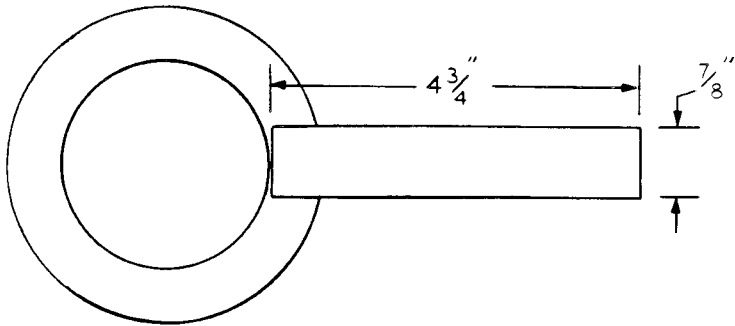

SHIM GAUGE

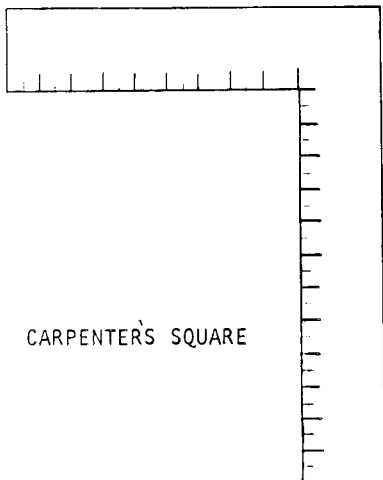

CARPENTER'S SQUARE

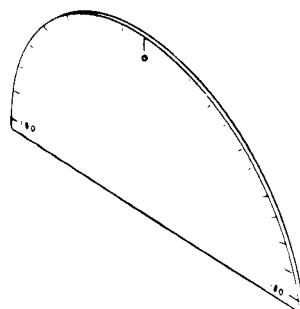

PROTRACTOR

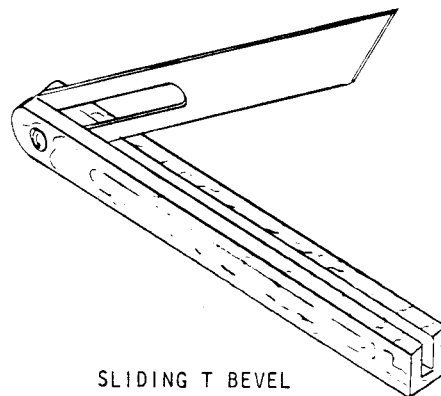

SLIDING T BEVEL

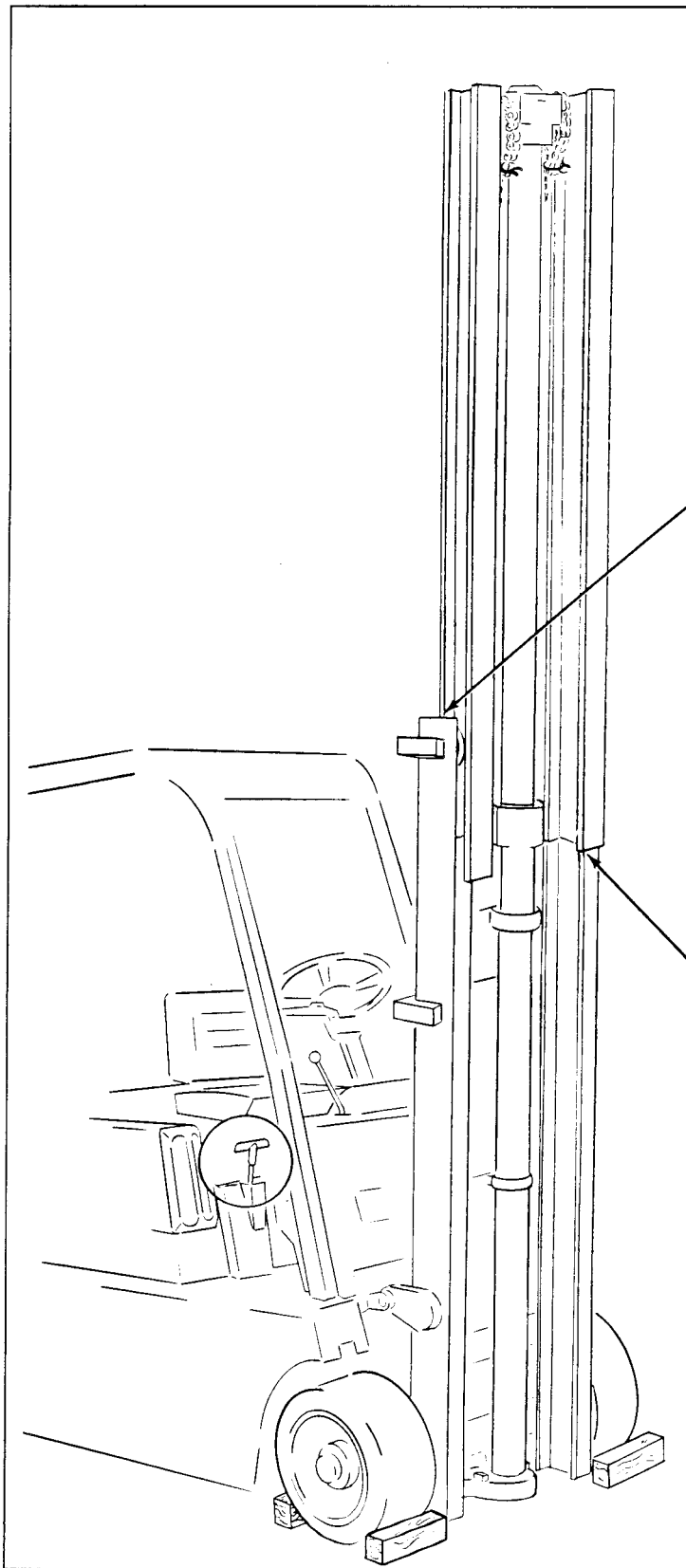

Step 1(c). Raise inner rail to full up position and with tool and bar, check for roller clearance in the manner as before.

Record number of shims to be used, on outer rail (for top rollers only).

Record number of shims to be used, on inner rail (for bottom rollers only).

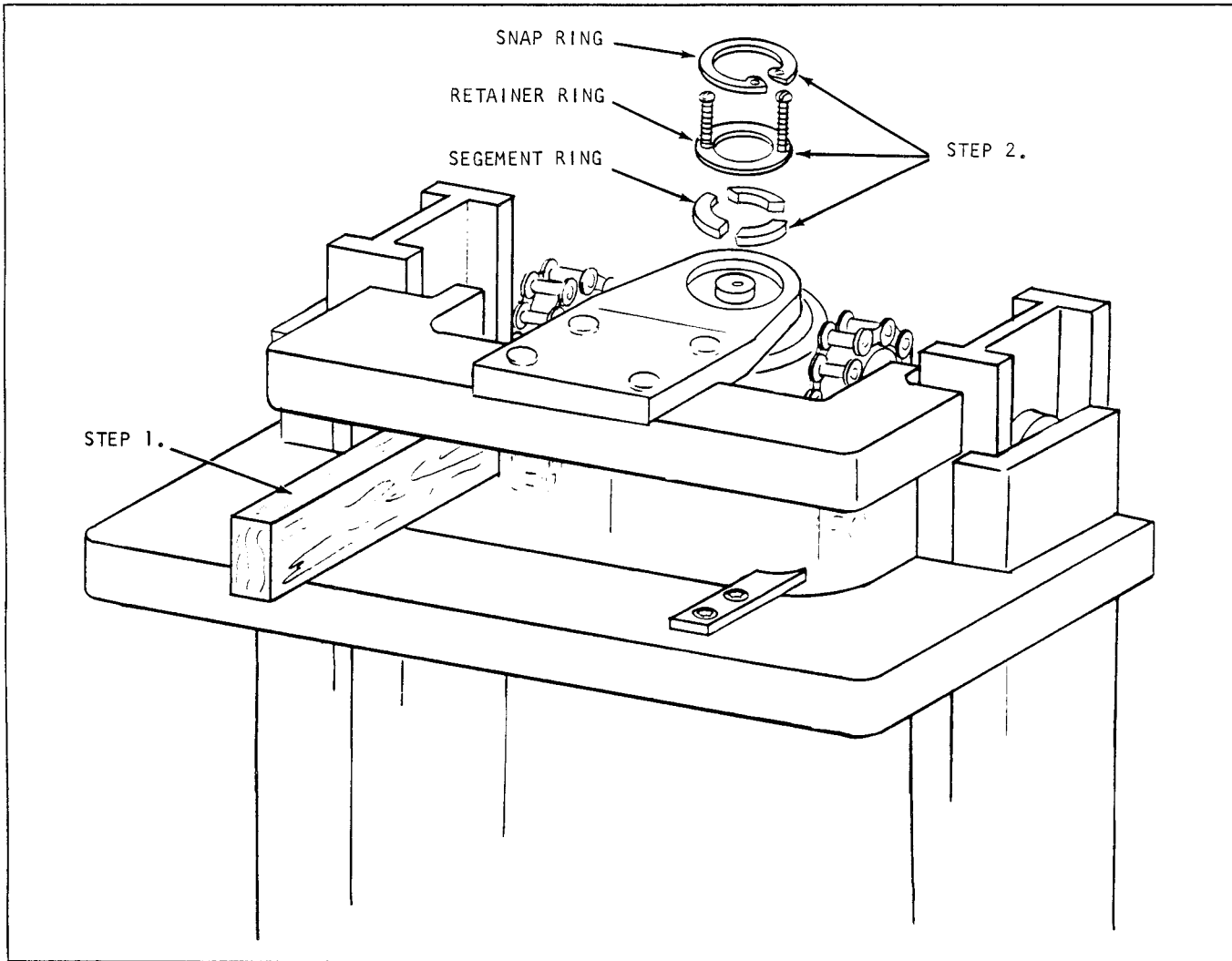

Plate 9627

REMOVAL OF INNER RAIL

Step 1. Raise inner rail about 5 inches and place a 2" x 4" block between upper tie bars. Lower inner rail until block supports it.

The upright you are working with may have a different piston anchor than the one shown above, remove it accordingly.

Step 2(a). Secure piston head with chain hoist.

(b). Remove lift cylinder from upper anchor

1. Remove snap ring

2. Place two (2) #6-32X2" round head slotted machine screws (in holes provided) in retainer ring.

(c). Remove segment ring.

UPRIGHT ROLLER ADJUSTMENT

UPRIGHT ROLLER ADJUSTMENT -- STANDARD AND HILO

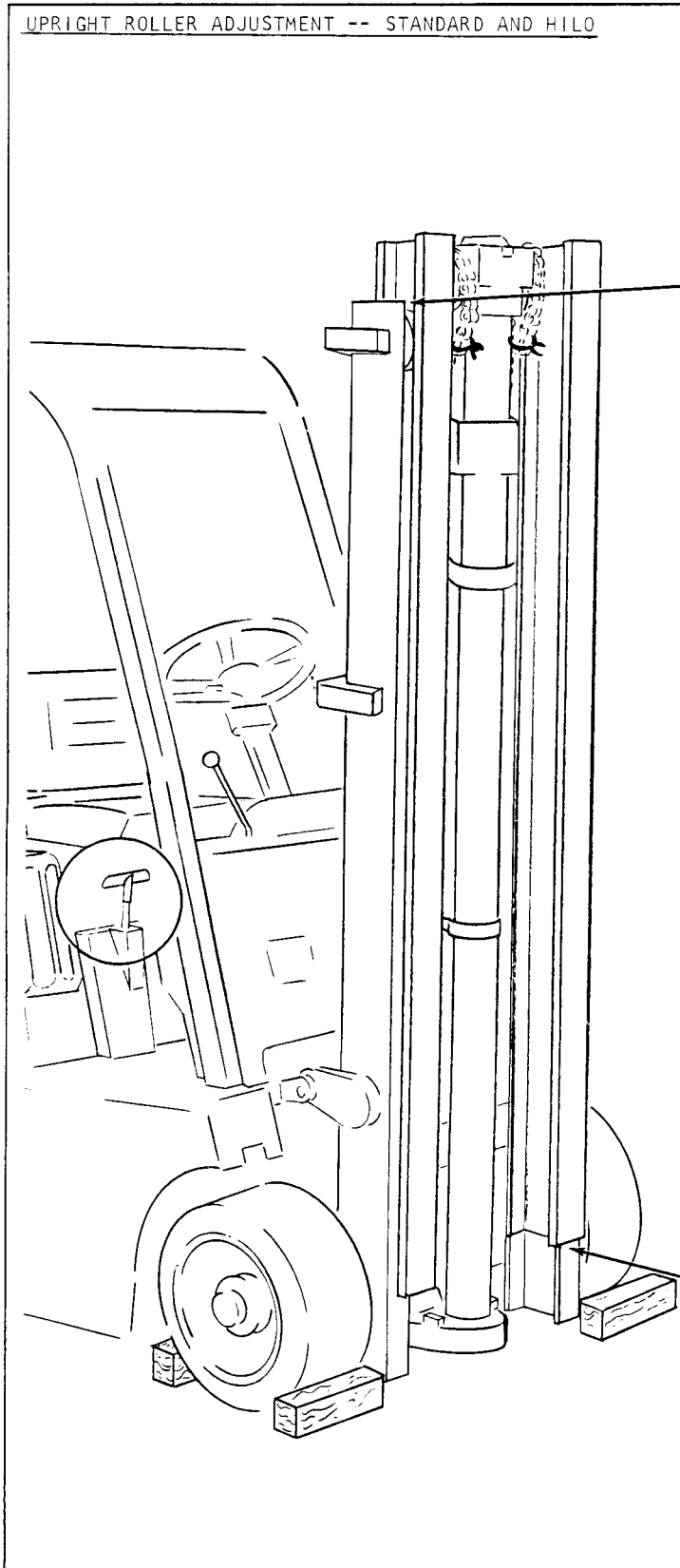

Step 1(a). Remove carriage. Refer to CARRIAGE REMOVAL.

Before checking roller clearance, position inner rail about 5" above full down position.

Check both sides for roller clearance at (top and bottom) of inner rail. Use tool to determine the number of shims to be added and record this number on the rail. Record number of shims to be used, on outer rail (for top rollers only). Record number of shims to be used on inner rail (for bottom rollers only).

There is to be some clearance but it is not to exceed 1/32".

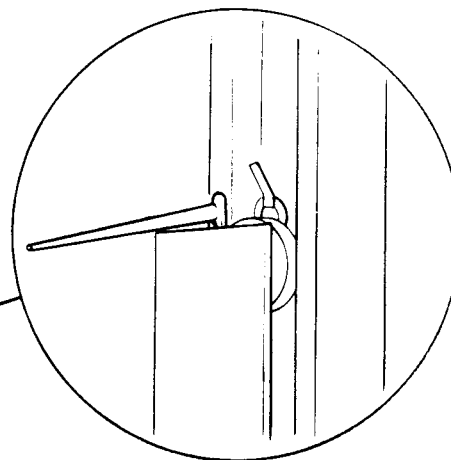
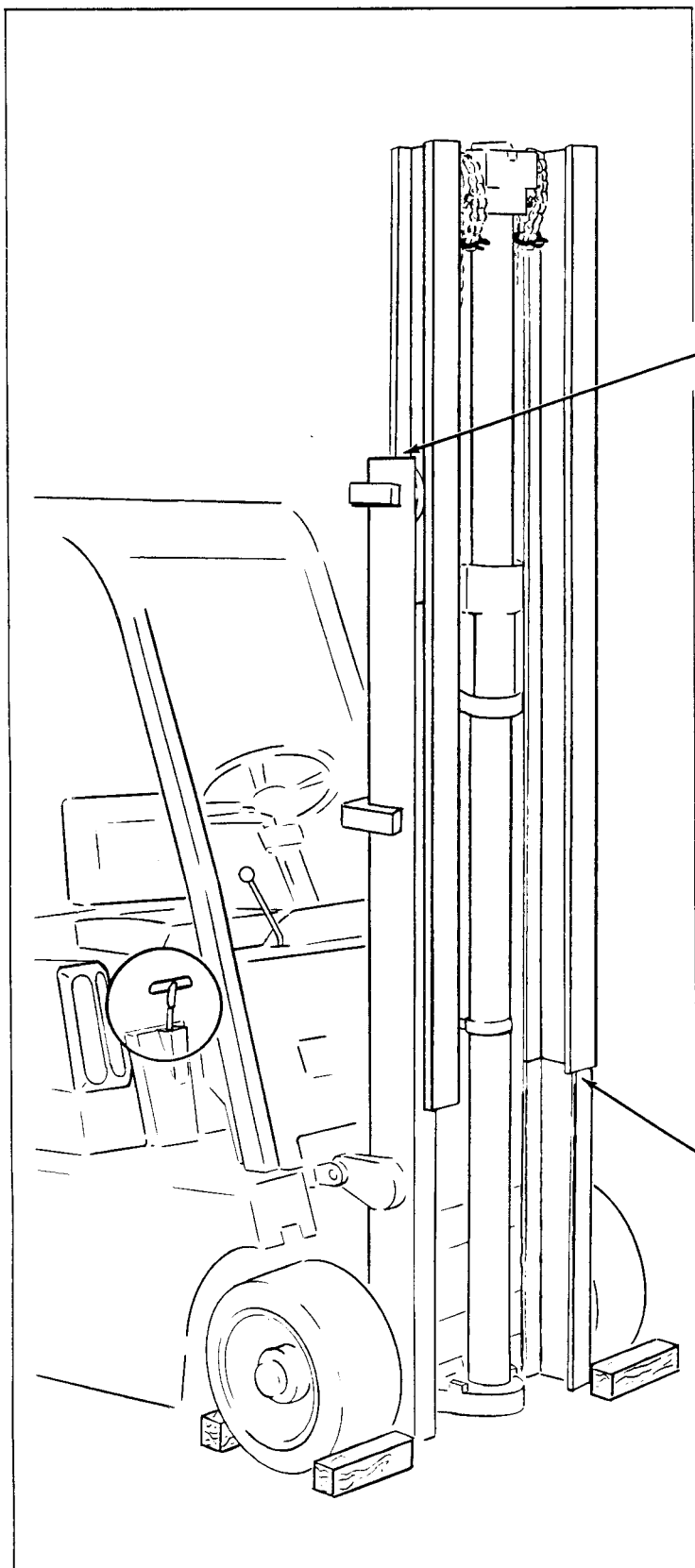

Step 1(b). Raise inner rail to 1/2 of its full up position. With tool and bar, check the roller clearance in the same manner as before.

Record number of shims to be used, on outer rail (for top rollers only).

Record number of shims to be used on inner rail (for bottom rollers only).

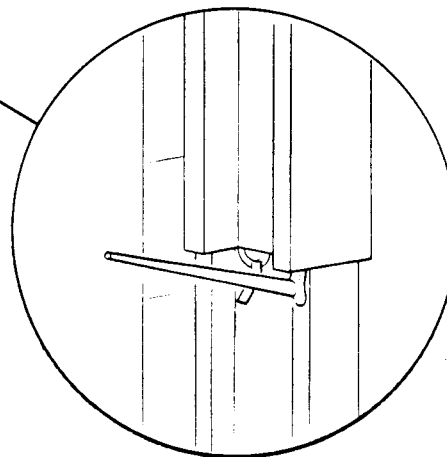

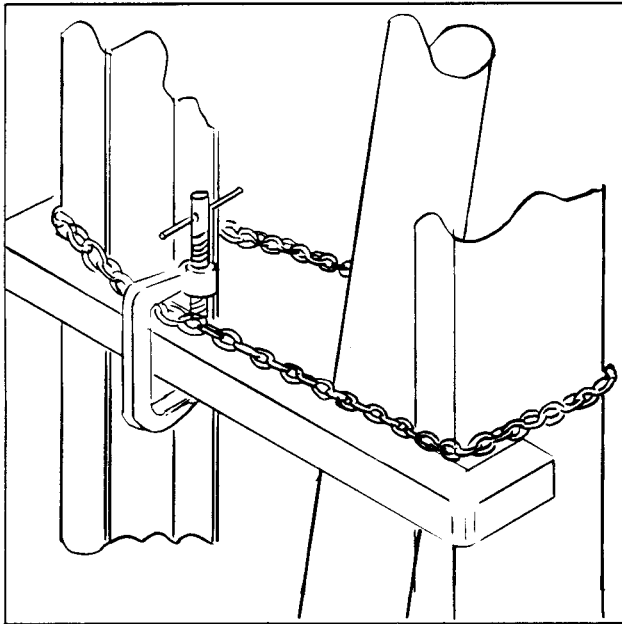

Plate 9628

Step 3. Place a safety strap or chain around outer rail as shown.

Step 4. Lower piston head out of anchor using pry bar. With the upright tilted forward the piston will rest on the strap or chain.

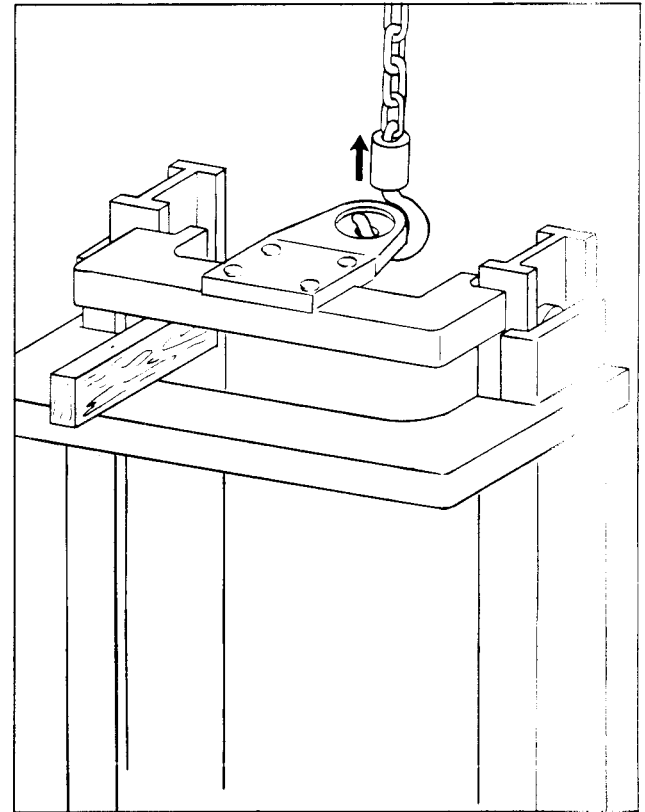

Plate 9630

Step 6. Place lifting device hook in hole of cylinder anchor. Raise about 2" and rest block between tie bars.

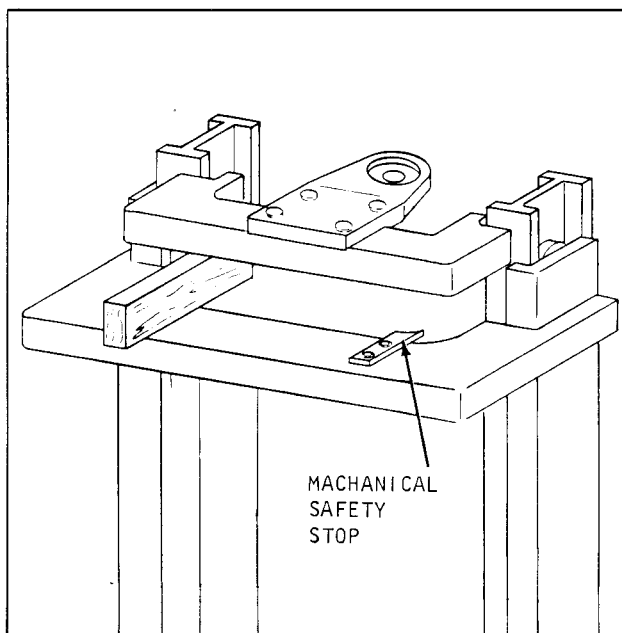
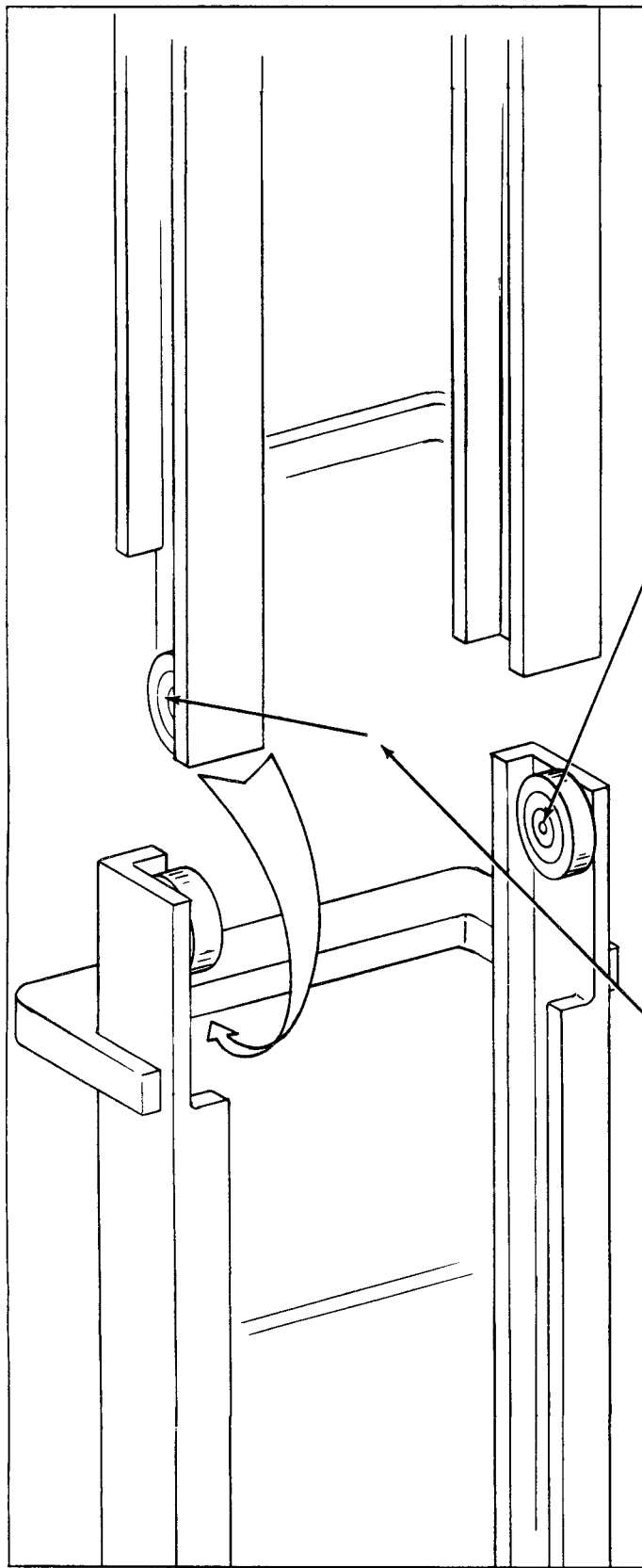

Plate 9629

Step 5. Remove mechanical safety stops with allen wrench.



Step 7. Raise inner rail out of outer rail.

Step 8. Leave inner rail in this position while adjusting rollers.

Step 9. Adjusting upright rollers:

A. Outer rail rollers.

1. Count the number of shims at the right and left hand rollers.

2. Look at the three (3) numbers you recorded on the outer rail in Step 1. The smallest of these numbers is the total number of shims to be added. A "0" means DO NOT add shims.

3. Your target for adjustment is to have the same number of shims at each upper roller. If you end up with an extra shim DO NOT remove it. Mark the side having an extra shim.

B. Inner rail rollers

1. Count the number of shims at the right and left hand rollers.

2. Look at the three (3) numbers you recorded on the inner rail in Step 1. Go through the same steps you followed in adjusting the upper rollers.

3. If you end up with an extra shim here too, be sure it is on the same side as the extra upper shim.

C. Replace inner rail.

Plate 9631

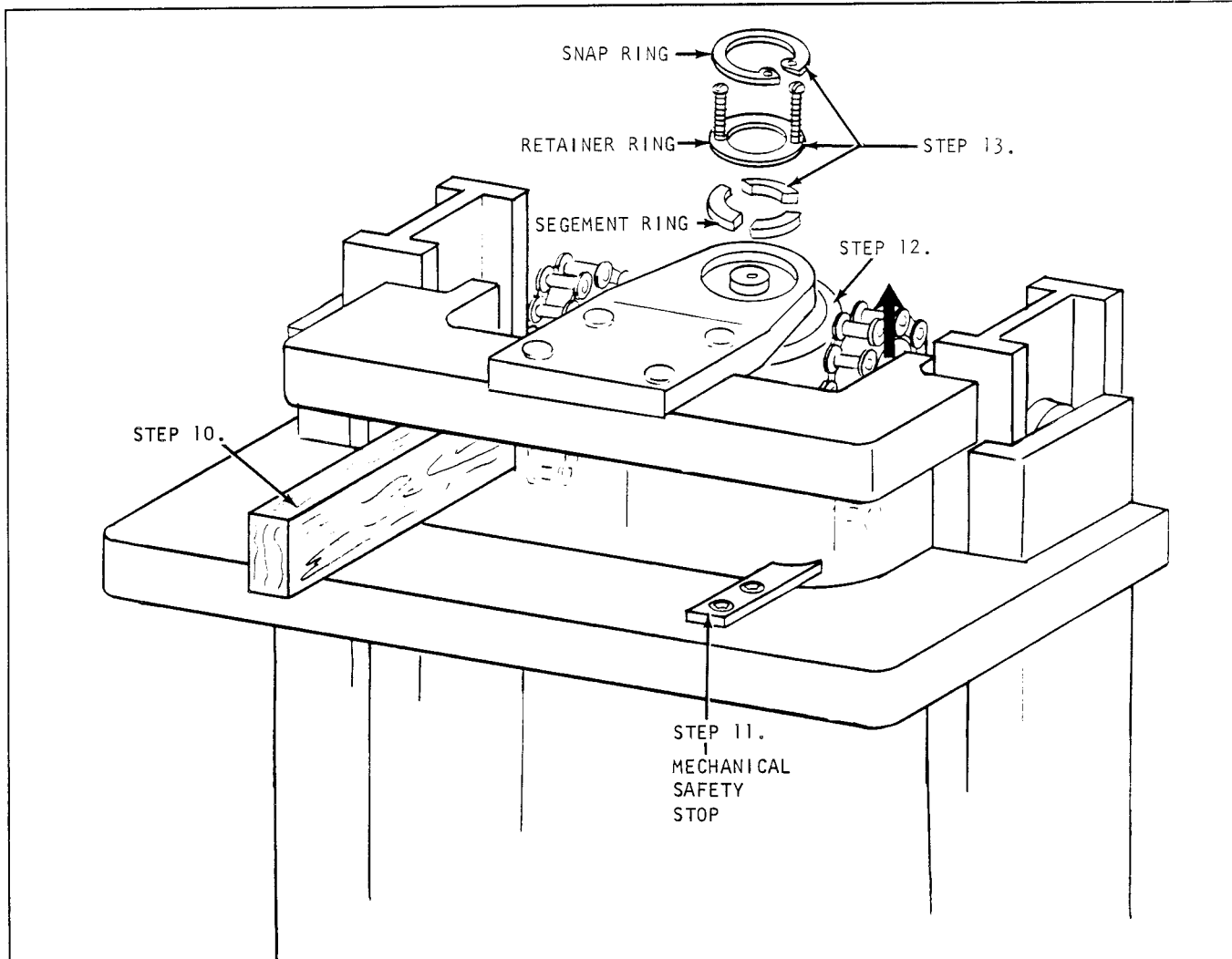

Plate 9632

Step 10(a). Place block between upper tie bars. Lower inner rail until block supports it.

(b). Unhook lifting device.

Step 11. Install mechanical safety stops. Be sure to install lock washer and screw fasteners.

Step 12. Guide piston into anchor with one hand and move the lift lever with the other.

Step 13. Secure lift cylinder to anchor.

(a). Install segment ring.

(b). Install retainer ring and remove both slotted machine screws.

(c). Install snap ring.

(d). Raise and lower to full positions checking piston and anchor. Remove block between tie bars.

UPRIGHT ROLLER ADJUSTMENT -- STD. AND F. F. TRIPLE

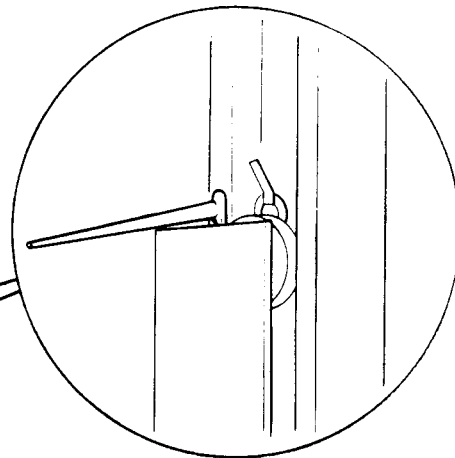
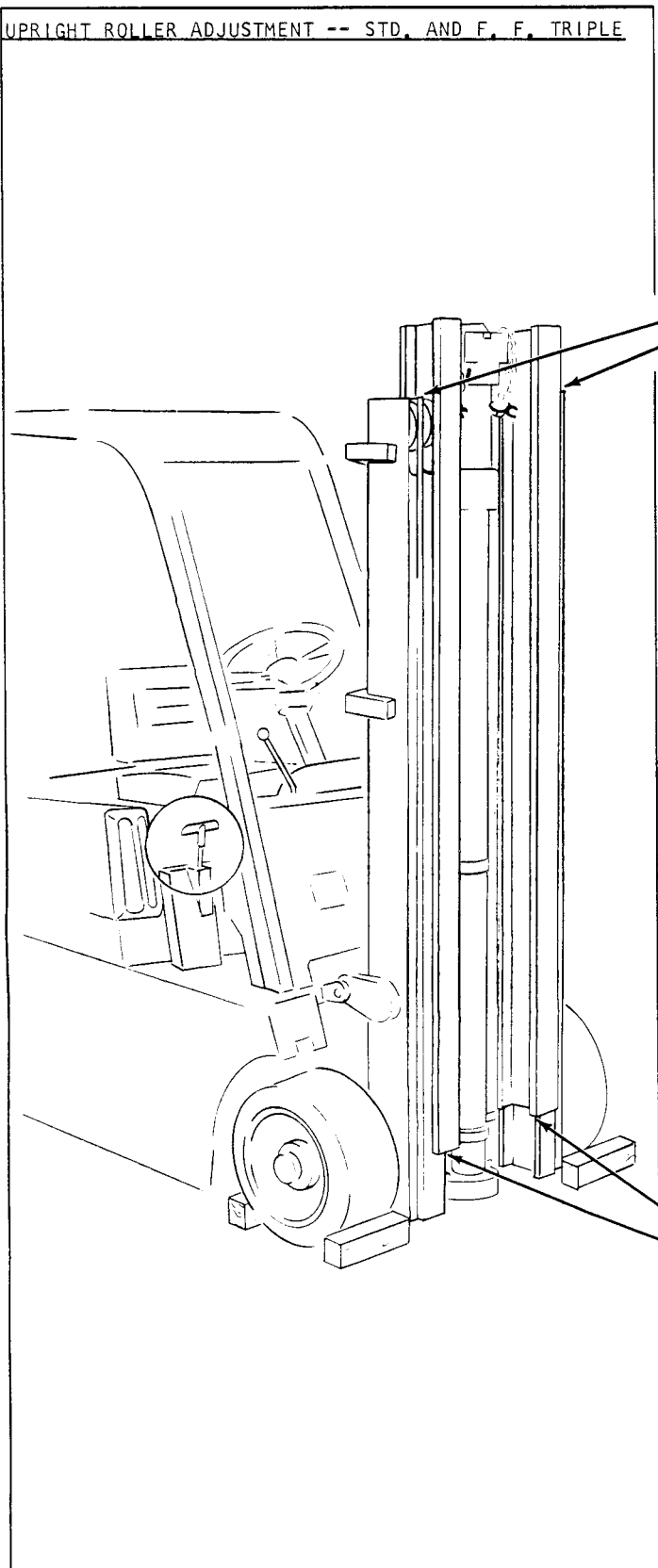

Step 1(a). Remove carriage.

Before checking, position inner rail about 5 inches above full down position.

Check both sides for roller clearance at (top and bottom) of inner rail. Use tool to determine the number of shims to be added and record this number on the rail.

Record number of shims to be used, on intermediate rail (for top rollers only).

Record number of shims to be used on inner rail (for bottom rollers only).

There is to be some clearance but it is not to exceed 1/32 inch.

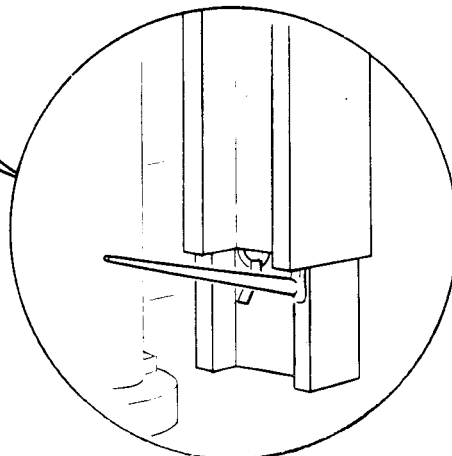

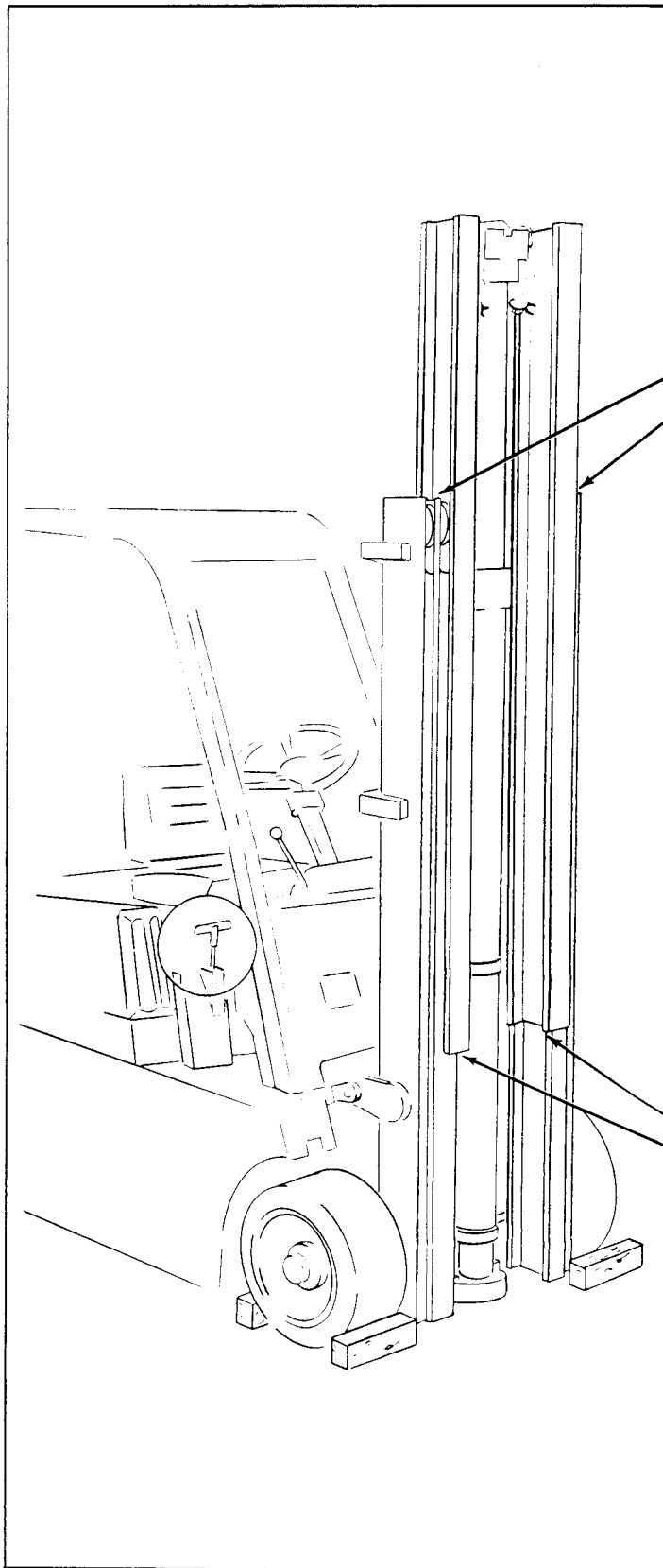

Step 1(b). Raise inner rail to 1/2 of its full up position. Check roller clearance in the same manner as before.

Record number of shims to be used, on intermediate rail (for top roller only).

Record number of shims to be used, on inner rail (for bottom rollers only).

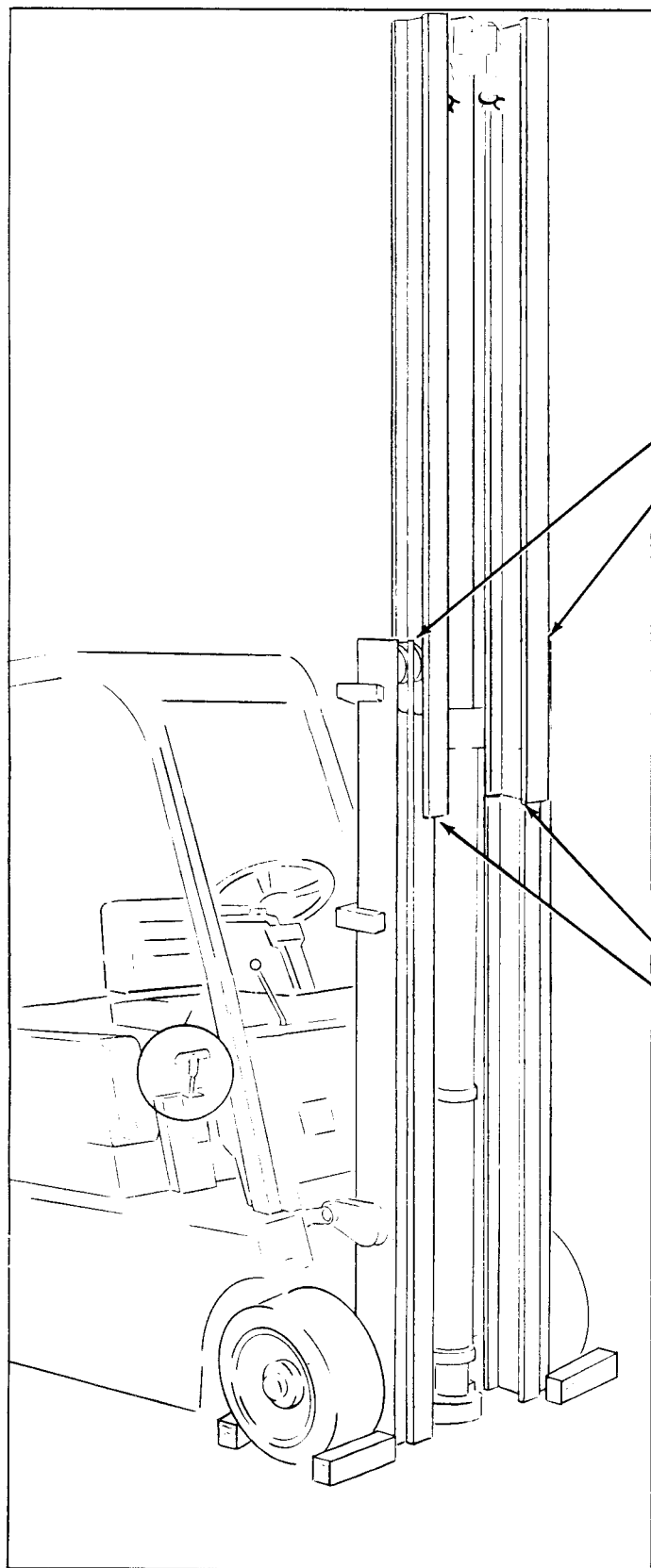

Step 1(c). Raise inner rail to full up position. Check roller clearance in the same manner as before.

Record number of shims to be used, on intermediate rail (for top rollers only).

Record number of shims to be used, on inner rail (for bottom rails only).

Plate 9638

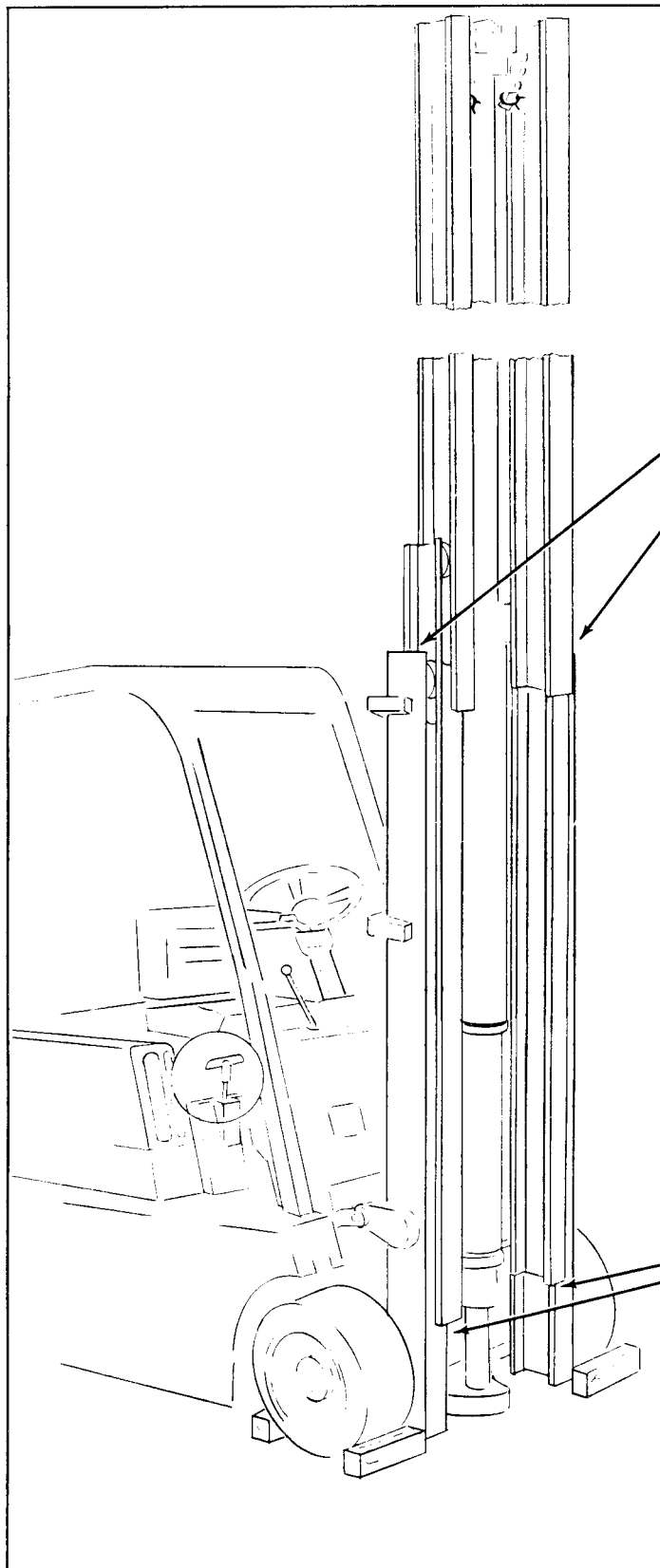

Step 2(a). Raise intermediate rail about 5 inches. Check roller clearance in the same manner as before.

Record number of shims to be used, on outer rail (for top rollers only).

Record number of shims to be used, on intermediate rail (for bottom rollers only).

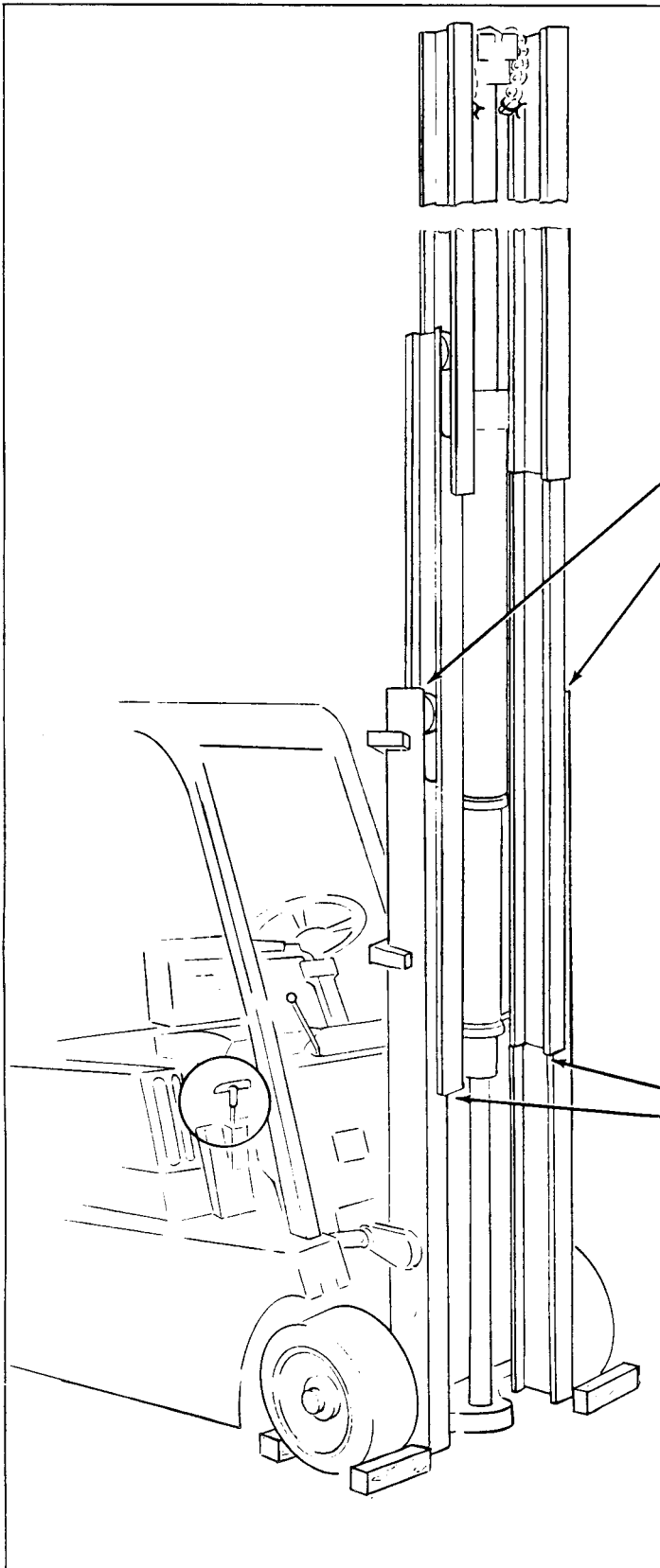

Step 2(b). Raise intermediate rail to 1/2 its full up position. Check roller clearance in the same manner as before.

Record number of shims to be used, on outer rail (for top rollers only).

Record number of shims to be used, on intermediate rail (for bottom rollers only).

Plate 9640

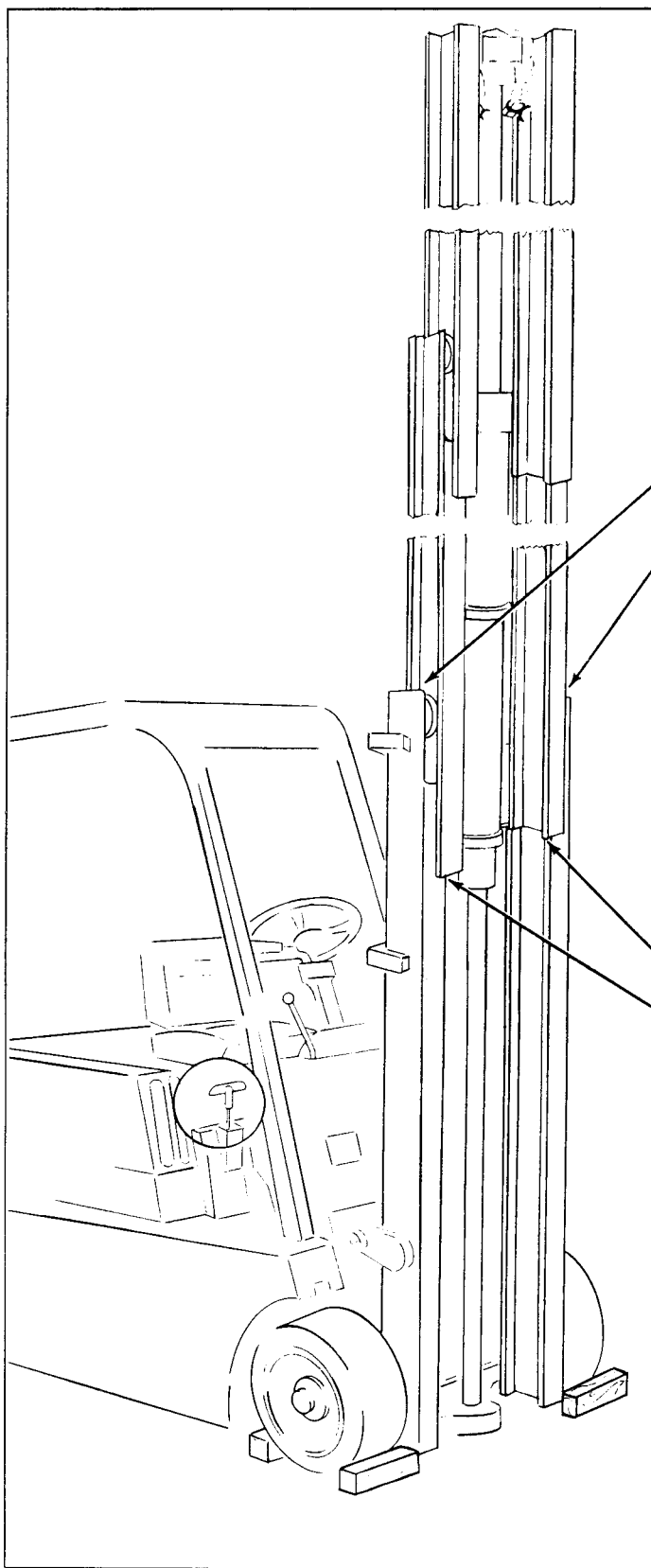

Step 2(c). Raise intermediate rail to full up position. Check roller clearance in the same manner as before.

Record number of shims to be used, on outer rail (for top rollers only).

Record number of shims to be used, on inner rail (for bottom rollers only).

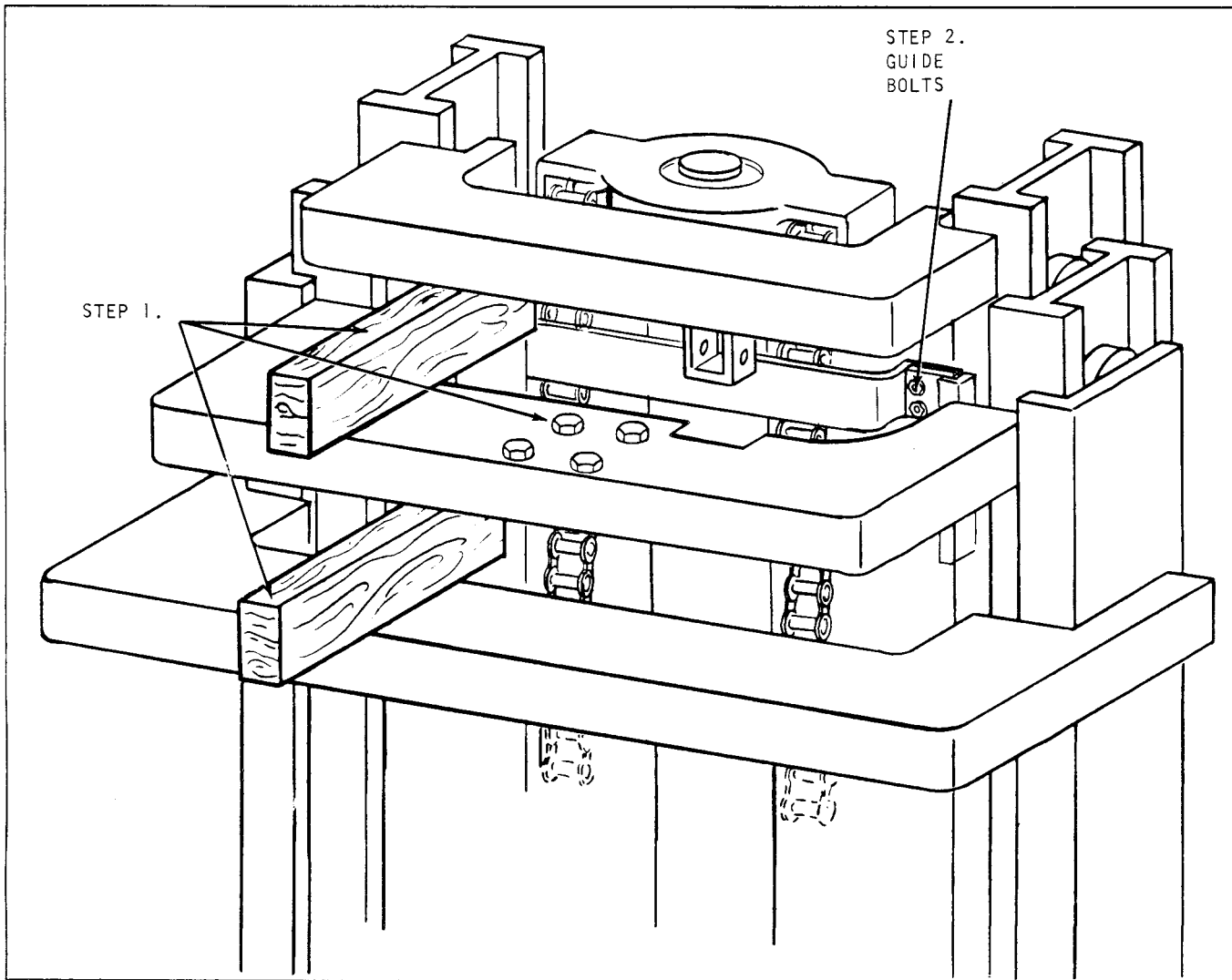

Plate 9642 Standard Triple Piston Head

REMOVAL OF RAILS--STANDARD TRIPLE

Step 1. Place blocks between inner and intermediate rail tie bars. Remove mechanical safety stops.

Step 2. Pull piston head down far enough to get at piston head guide bolts. Remove both piston head guides.

Step 3. Pull piston head to full down position.

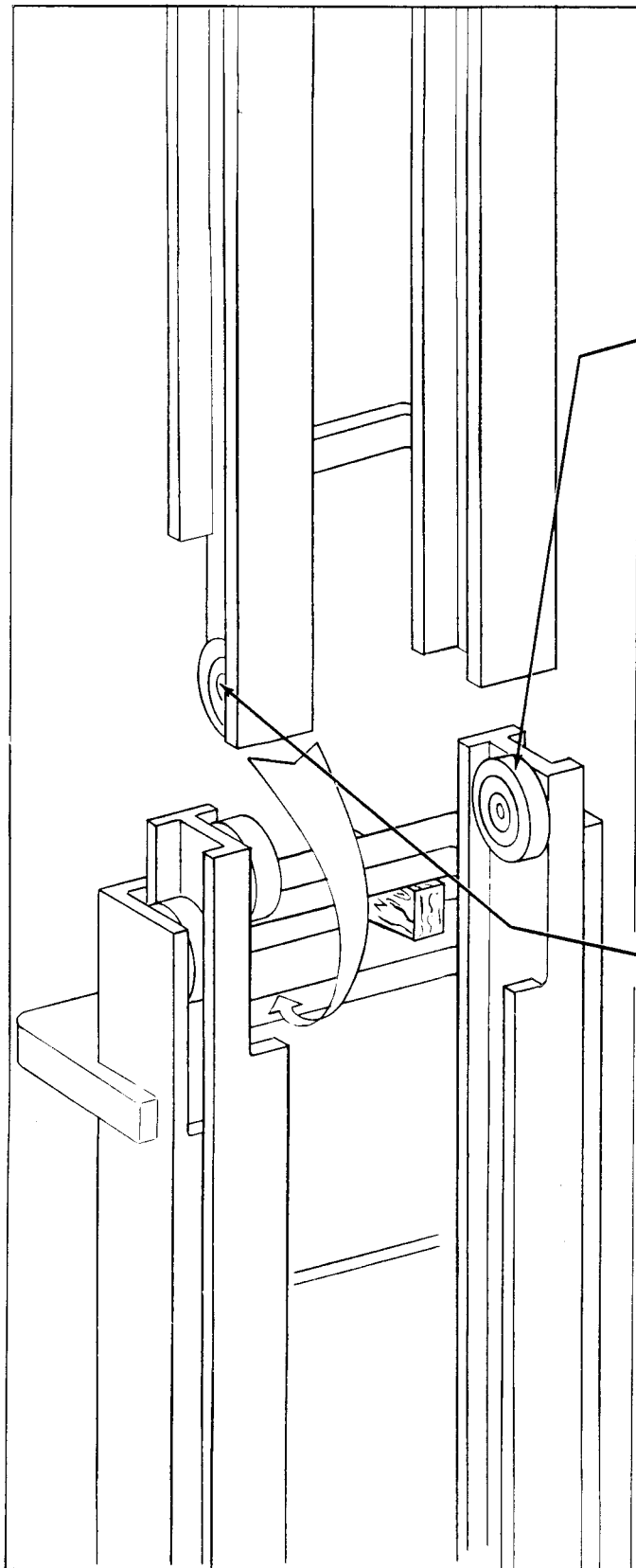

Step 4. Remove inner rail and leave it in this position while adjusting rollers.

A. Intermediate rail rollers:

1. Count the number of shims at the right and left hand rollers.

2. Look at the three (3) numbers you recorded on the intermediate rail in Step 1. The smallest of these numbers is the total number of shims to be added. A "0" means DO NOT add shims.

3. Your target for adjusting is to have the same number of shims at each upper roller. If you end up with an extra shim DO NOT remove it. Mark the side having an extra shim.

B. Inner rail rollers.

1. Count the number of shims at the right and left hand rollers.

2. Look at the three (3) numbers you recorded on the inner rail in Step 1. Go through the same steps you followed in adjusting the upper rollers.

3. If you end up with an extra shim here too, be sure it is on the same side as the extra upper shim.

C. Replace inner rail.

NOTE

Refer to next page.

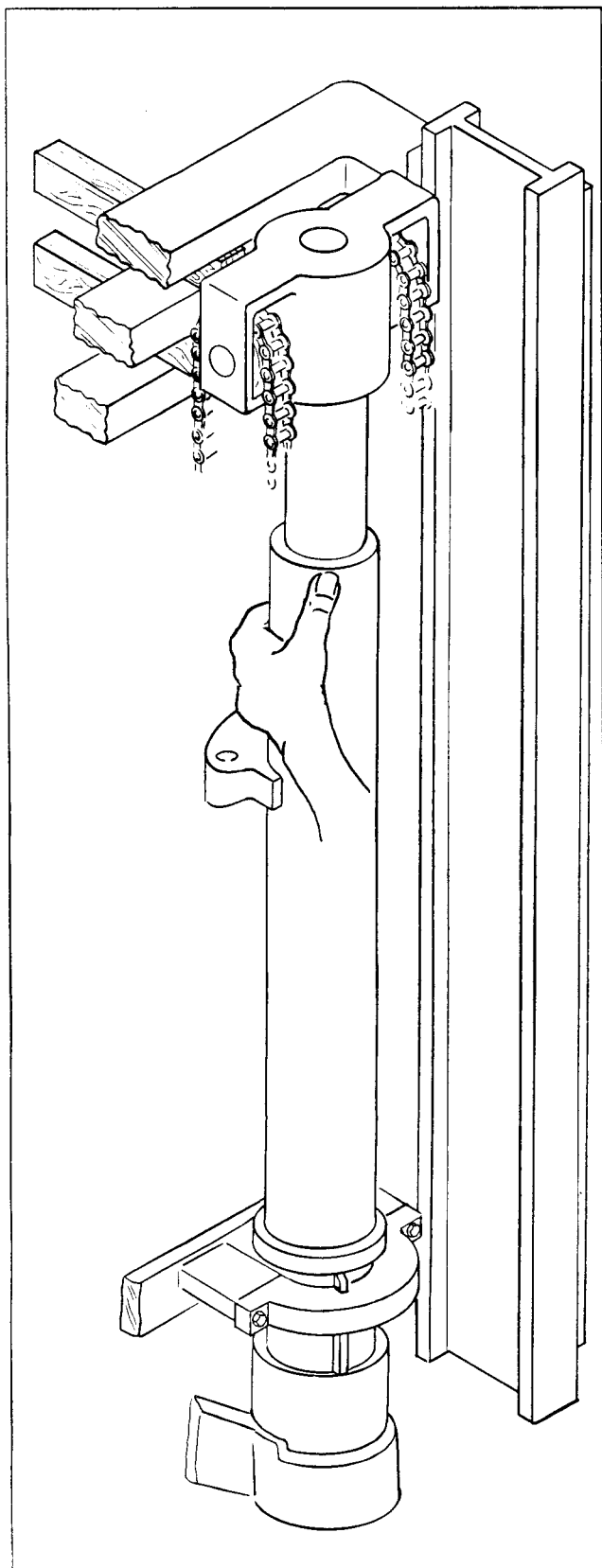

N O T E

With one hand pull piston head forward to let tie bar pass by piston head freely.

Plate 9644

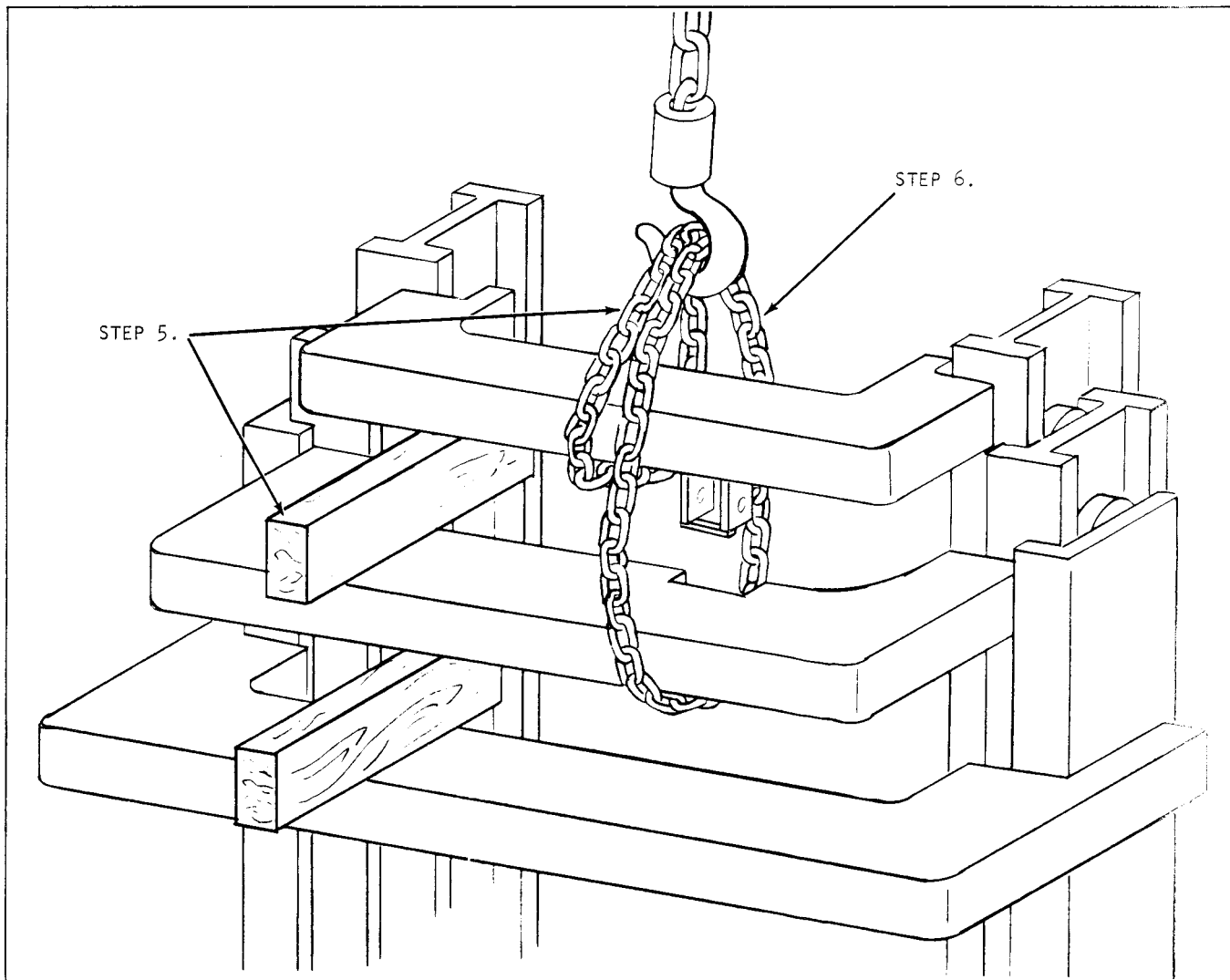

Plate 9645 Chain Placement

Step 5. Replace block and remove chain hoist.

Step 6. Remove intermediate rail assembly.

(a). Place chain around inner and intermediate rail assembly as shown above.

Step 6(b). Place a strap or chain around outer rail and secure. This will support lift cylinder.

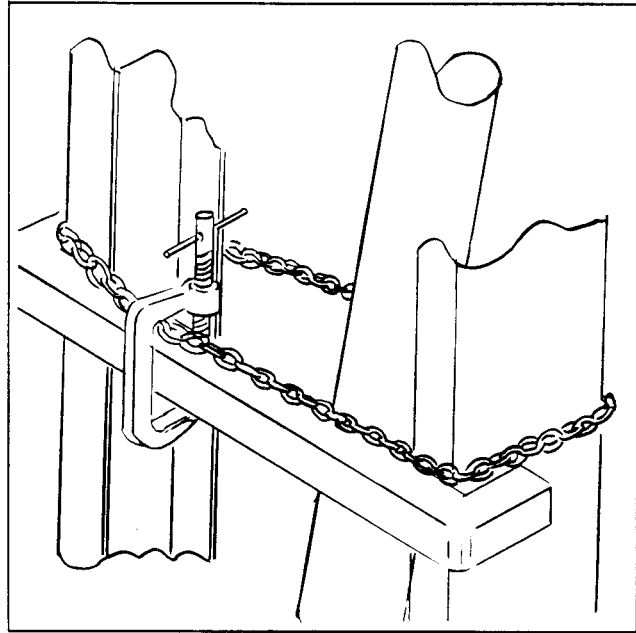

Plate 9628

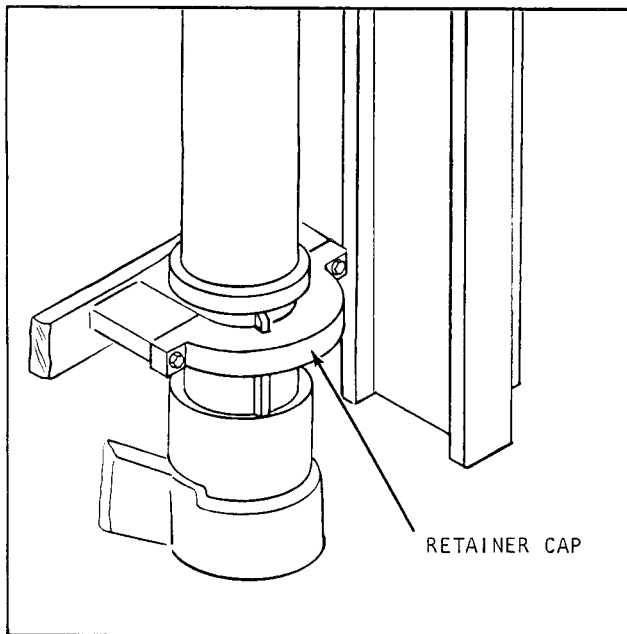
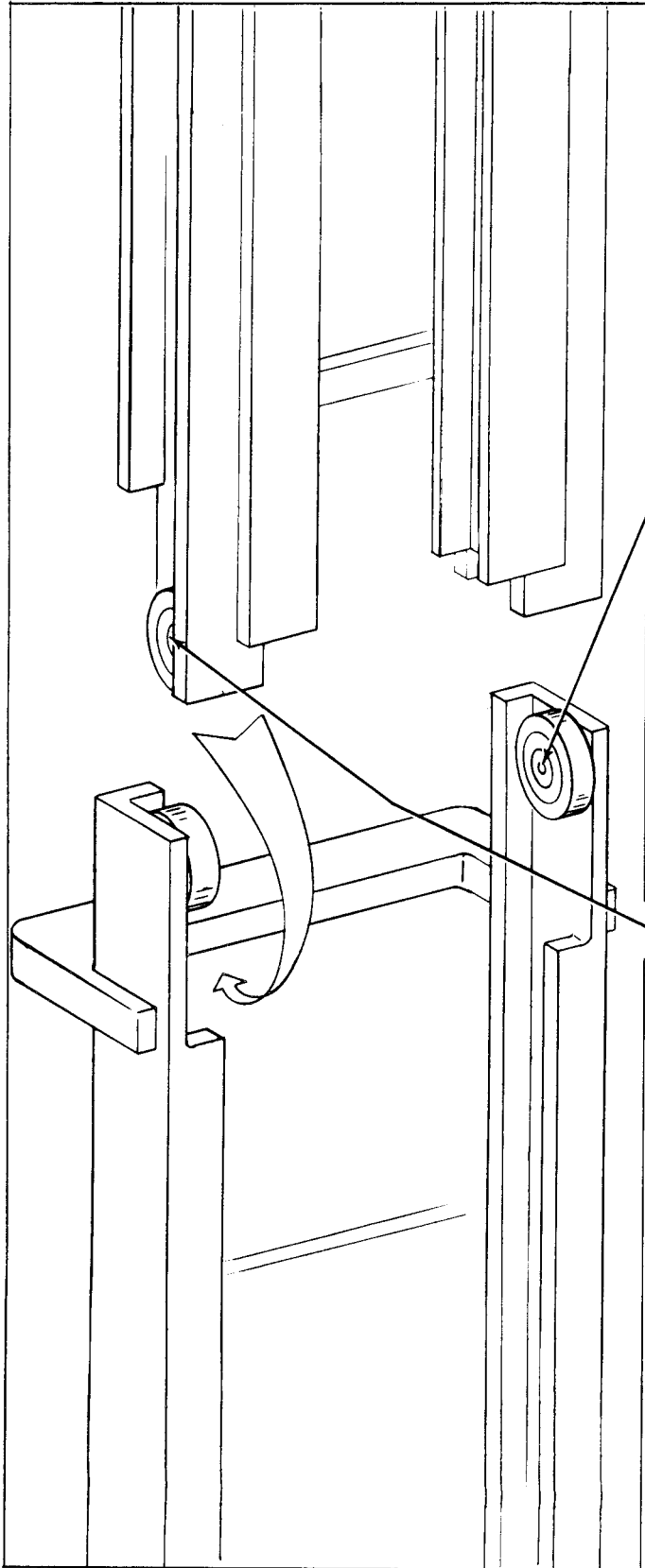

Plate 9646

Step 6(c). Remove lift cylinder retainer cap.



Step 6(d). Lean cylinder forward to rail on strap, as shown in Plate

Step 6(e). Leave intermediate rail assembly in this position while adjusting rollers.

A. Outer rail rollers:

1. Count the number of shims at the right and left hand rollers.
2. Look at the three (3) numbers you recorded on the outer rail in Step 1. The smallest of these numbers is the total number of shims to be added. A "0" means DO NOT add shims.
3. Your target for adjustment is to have the same number of shims at each upper roller. If you end up with an extra shim DO NOT remove it. Mark the side having an extra shim.

B. Intermediate rail rollers:

1. Count the number of shims at the right and left hand rollers.
2. Look at the three numbers you recorded on the intermediate rail in Step 1. Go through the same steps you followed in adjusting the upper rollers.
3. If you end up with an extra shim here too, be sure it is on the same side as the extra upper shim.

C. Replace intermediate rail assembly.

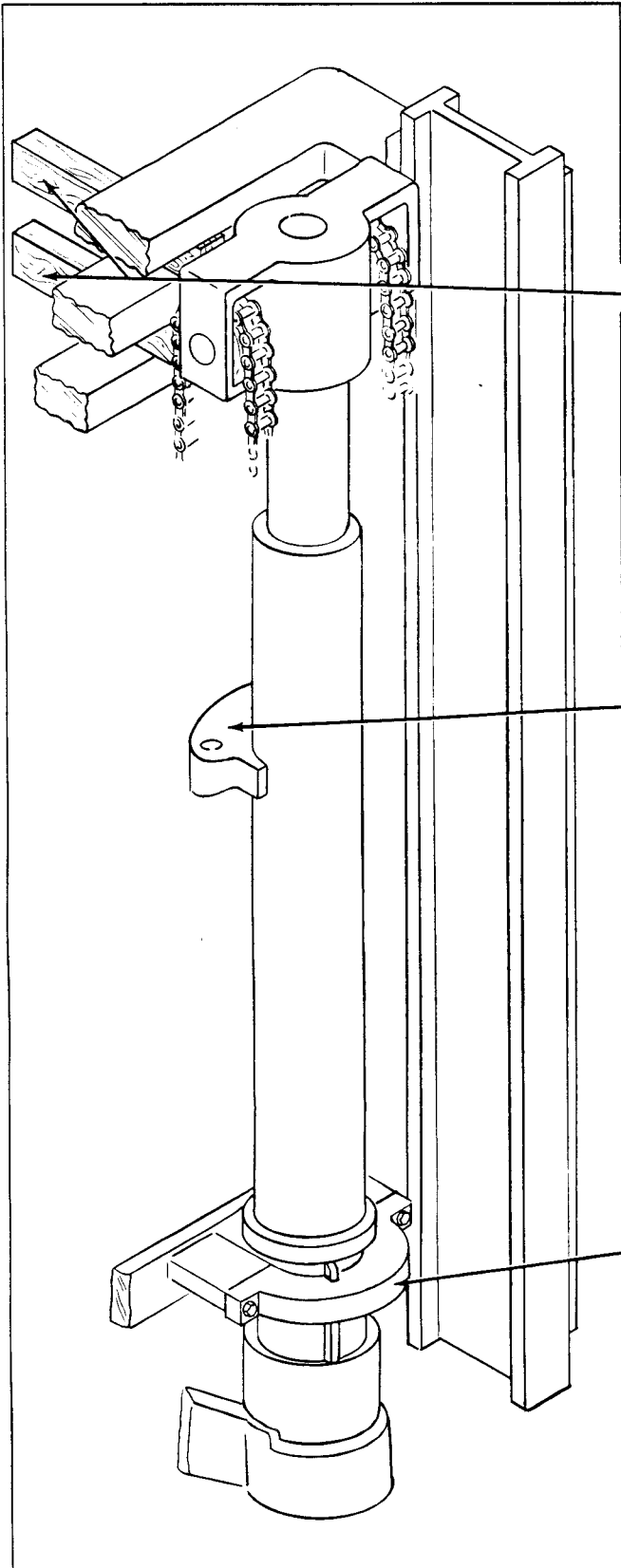

Step 6(f). Replace block between intermediate rail assembly tie bar and remove chain.

Step 7. Place chain around chain anchors on cylinder. Use hoist to support cylinder.

Step 8. Remove supporting strap.

Step 9. Install cylinder retainer cap.

Plate 9648

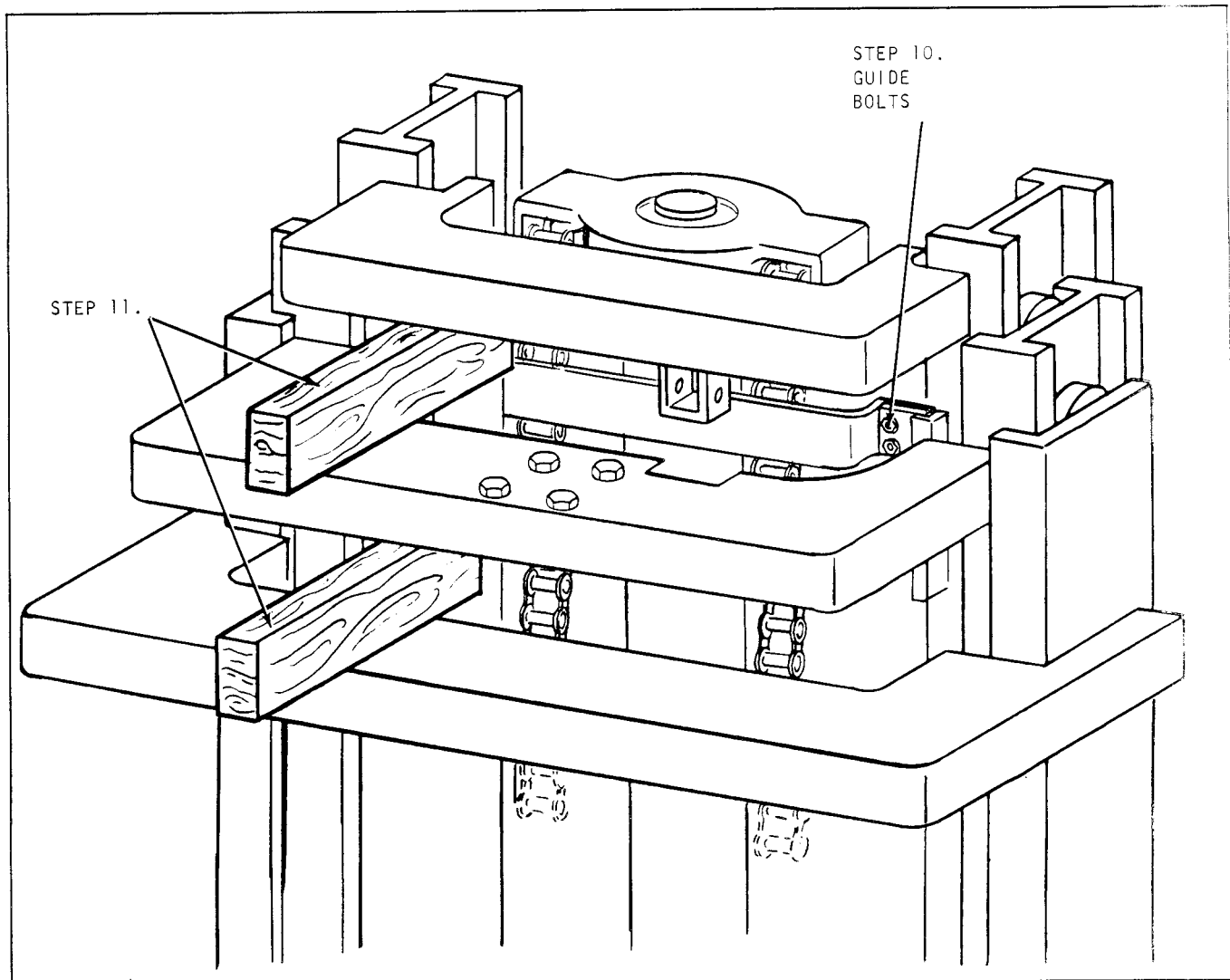

Plate 9649 Standard Triple Piston Head

Step 10. Install both piston head guides.

Step 11. Install mechanical stop. Raise rails and remove blocks.

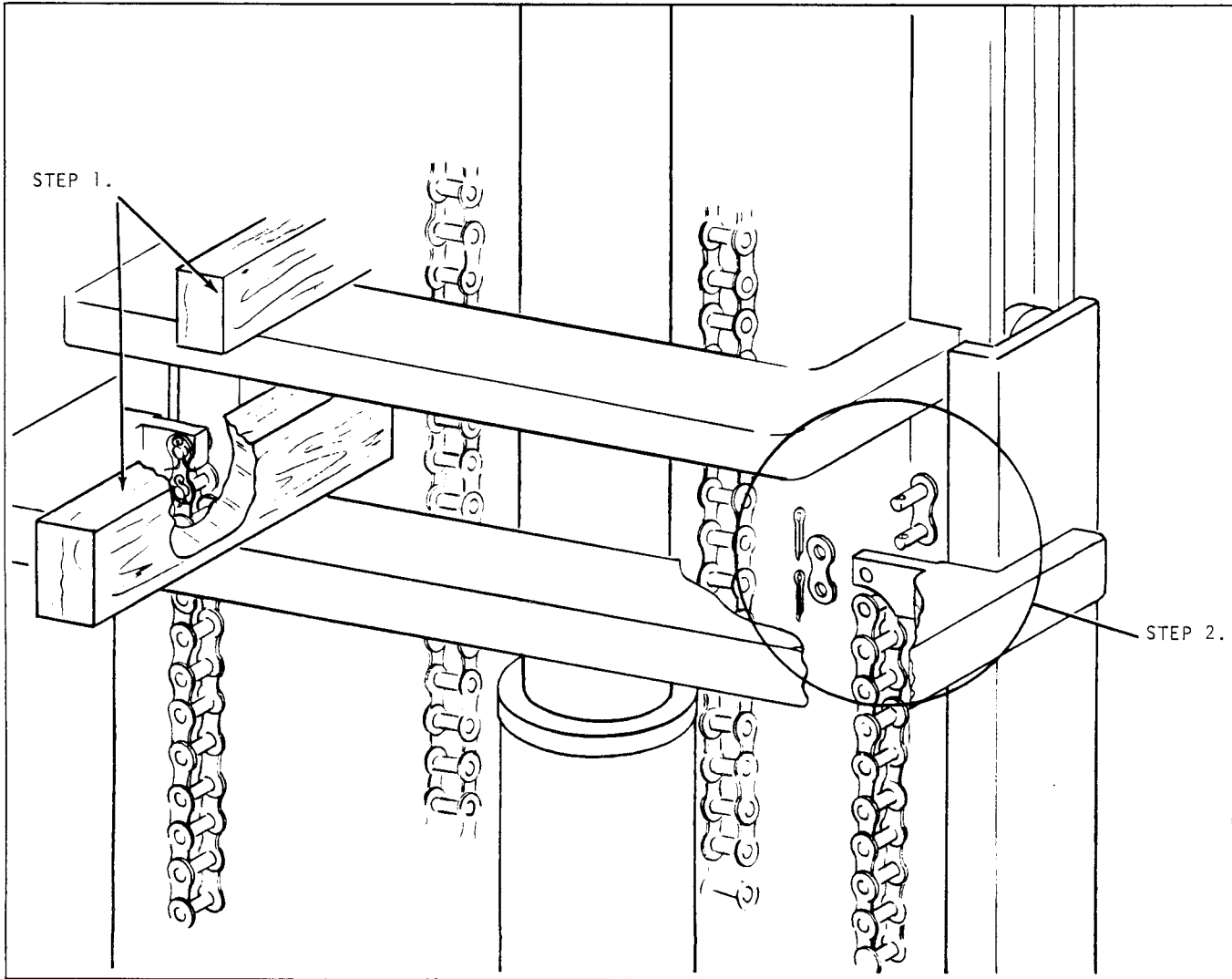

Plate 9650 Rear Lift Cylinder Removal

UPRIGHT REMOVAL--FULL FREELIFT TRIPLE

- Step 1. Place blocks between inner and intermediate rail tie bars.
- Step 2. Remove rear lift chains at the top or master link end.

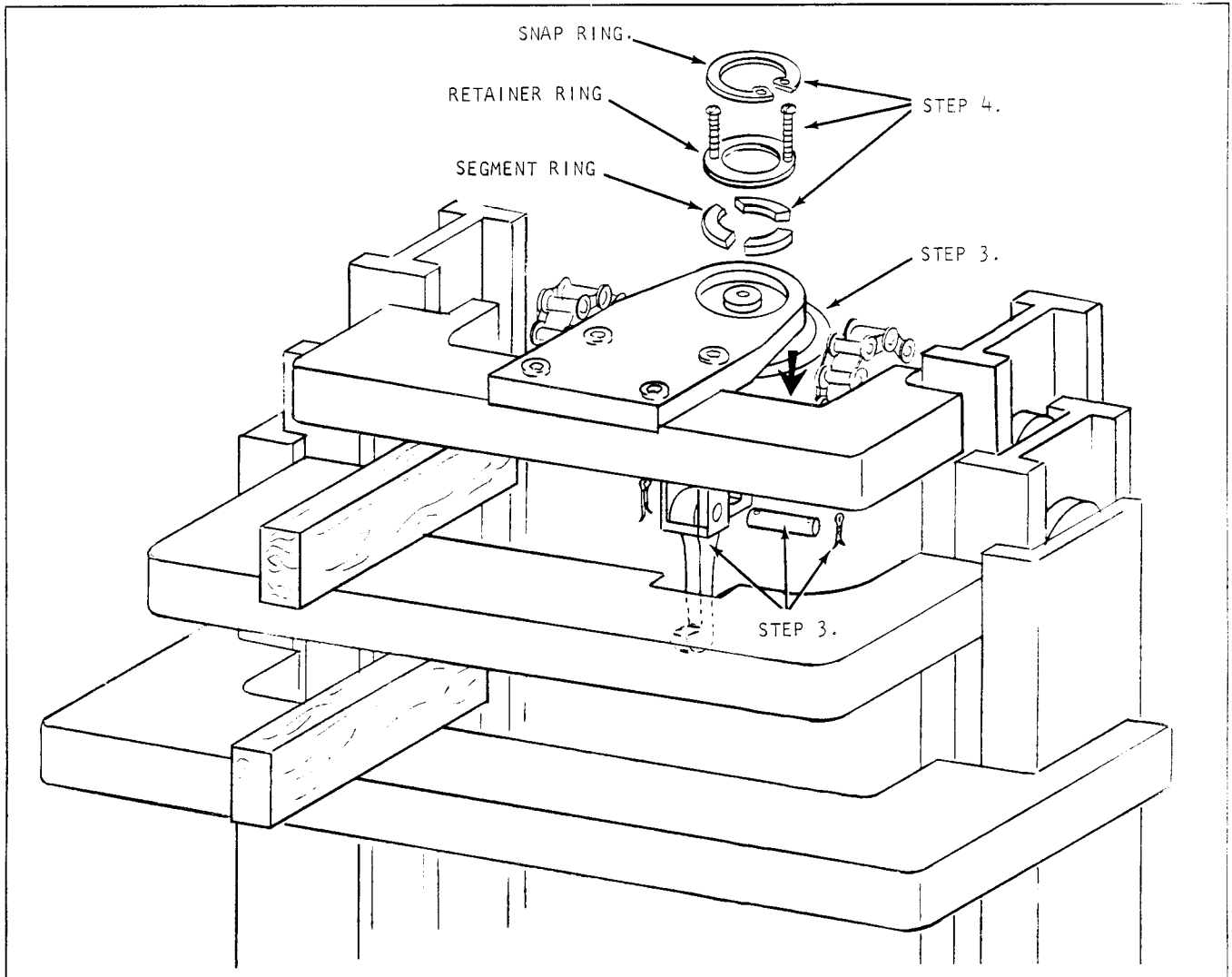

Plate 9651 F.F.T. Piston Head

Step 3. Pull piston head down

Remove mechanical safety stop pin and remove stop.

Step 4(a). Secure piston head with chain hoist.

(b). Remove lift cylinder from upper anchor.

1. Remove snap ring.

2. Place two (2) #6-32X2" round head slotted machine screws (in holes provided) in retainer ring.

(c). Remove segment ring.

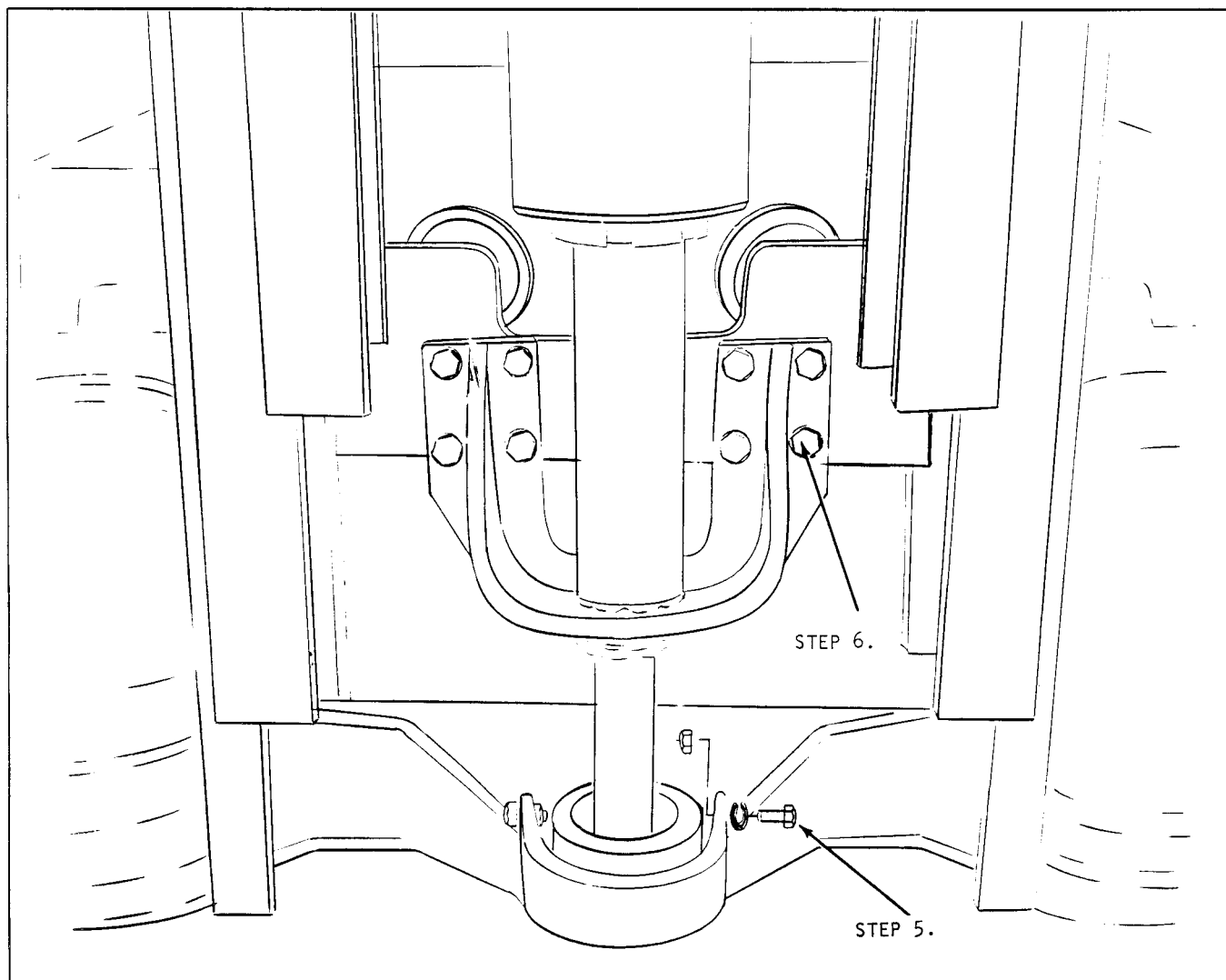

Plate 9652 Cylinder Lifting Bracket

Step 5. Remove lift cylinder support bolts.

Step 6. Remove cylinder lifting bracket.

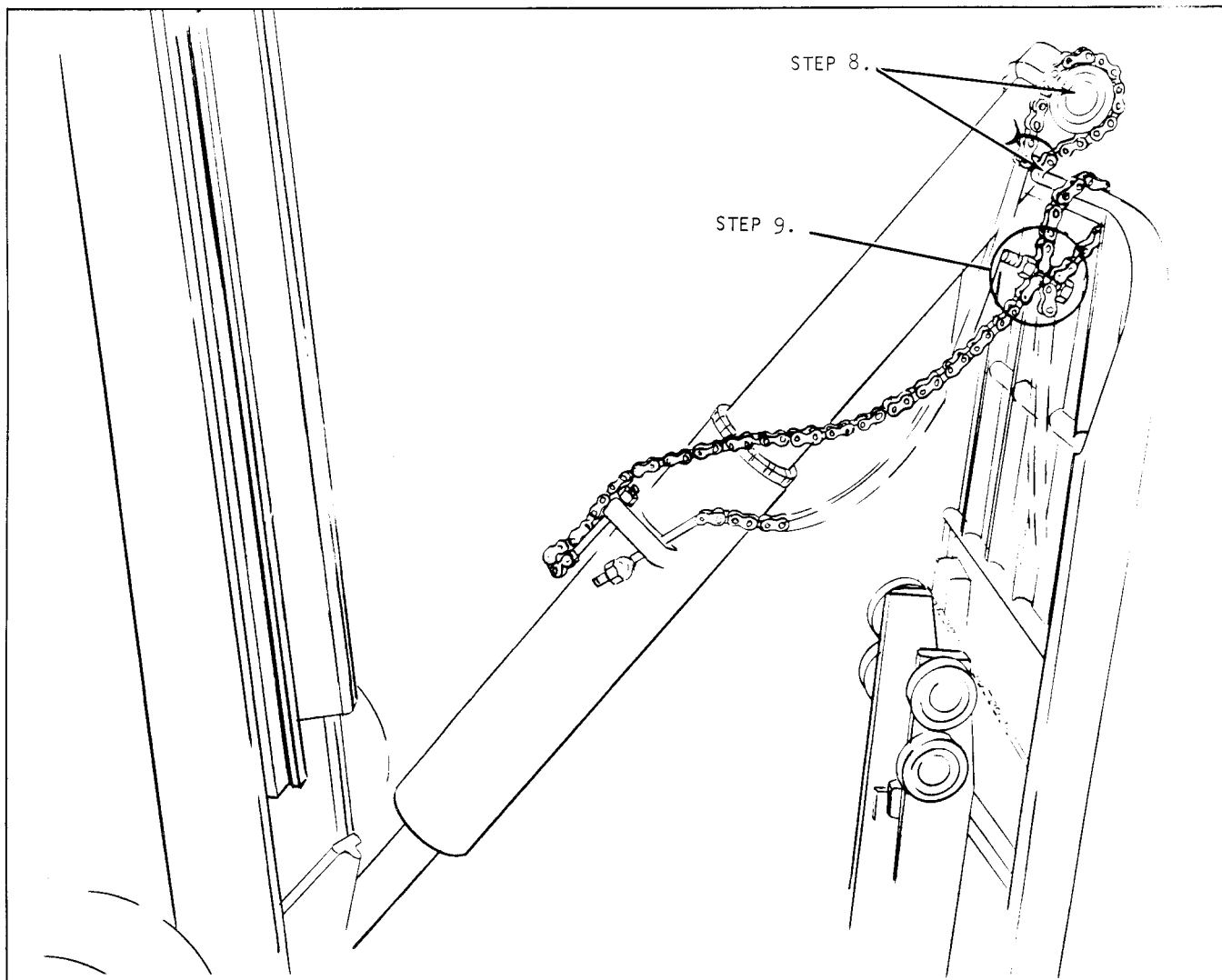

Plate 9653 Supporting Cylinder

Step 7. Lower cylinder and lean it toward the load back rest (on the carriage).

Step 8. Place padding type material on the load back rest to prevent scoring of the cylinder.

Let cylinder rest onto load back rest.

Step 9. Place rear lift chains around top bar of load back rest and place bolts through chain, as shown above. This will prevent cylinder from falling.

Step 10. Remove inner rail and leave it in this position while adjusting rollers.

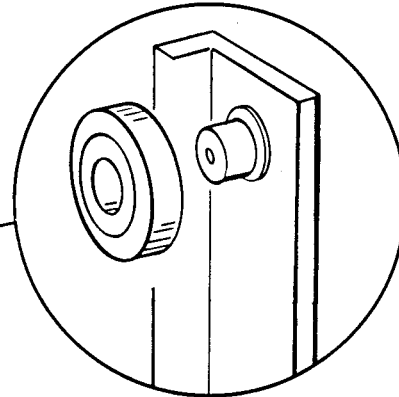
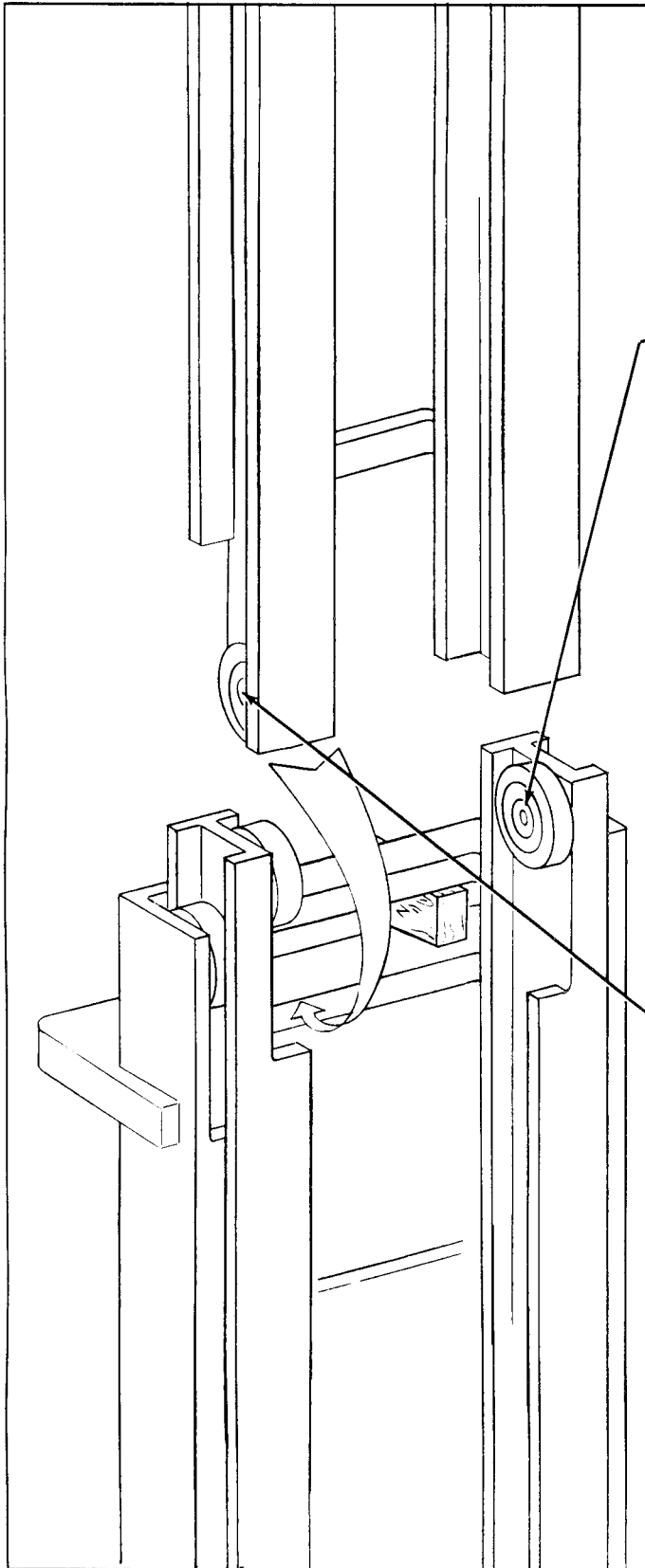

A. Intermediate rail rollers:

1. Count the number of shims at the right and left hand rollers.
2. Look at the three (3) numbers you recorded on the intermediate rail in Step 1. The smallest of these numbers is the total number of shims to be added. A "0" means DO NOT add shims.
3. Your target for adjusting is to have the same number of shims at each upper roller. If you end up with an extra shim DO NOT remove it. Mark the side having an extra shim.

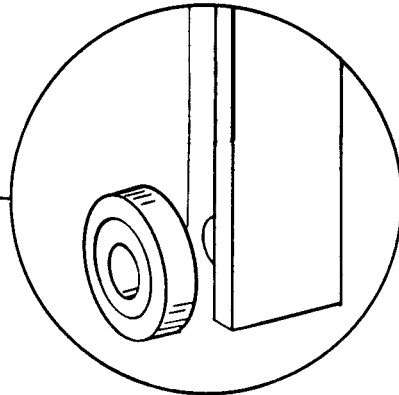

B. Inner rail rollers.

1. Count the number of shims at the right and left hand rollers.
2. Look at the three (3) numbers you recorded on the inner rail in Step 1. Go through the same steps you followed in adjusting the upper rollers.
3. If you end up with an extra shim here too, be sure it is on the same side as the extra upper shim.

C. Replace inner rail.

Plate 9654

Step 11. Leave intermediate rail assembly in this position while adjusting rollers.

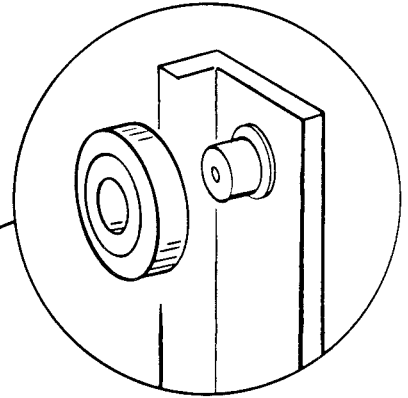
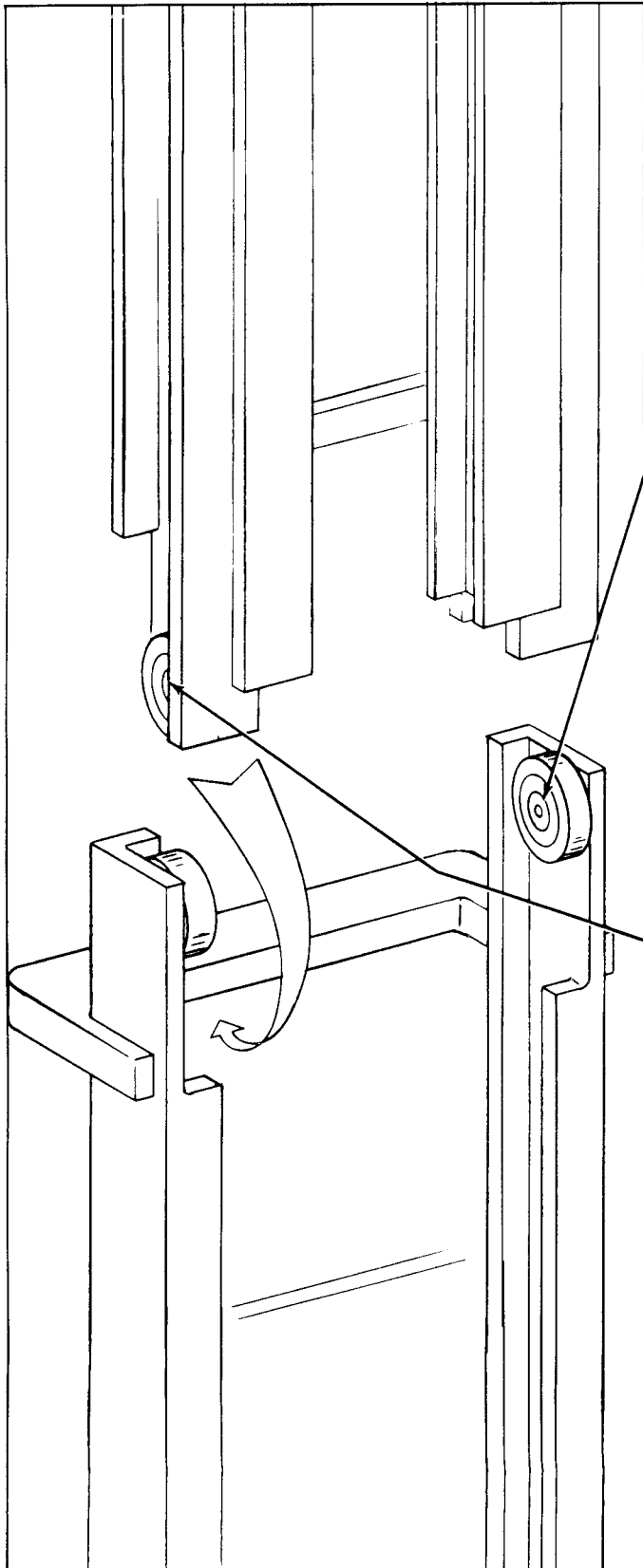

A. Outer rail rollers:

1. Count the number of shims at the right and left hand rollers.
2. Look at the three (3) numbers you recorded on the outer rail in Step 1. The smallest of these numbers is the total number of shims to be added. A "0" means DO NOT add shims.
3. Your target for adjustment is to have the same number of shims at each upper roller. If you end up with an extra shim DO NOT remove it. Mark the side having an extra shim.

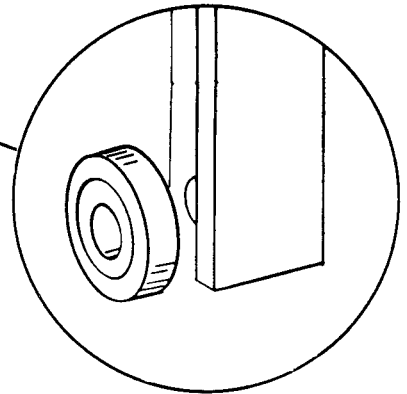

B. Intermediate rail rollers:

1. Count the number of shims at the right and left hand rollers.
2. Look at the three numbers you recorded on the intermediate rail in Step 1. Go through the same steps you followed in adjusting the upper rollers.
3. If you end up with an extra shim here too, be sure it is on the same side as the extra upper shim.

C. Replace intermediate rail assembly.

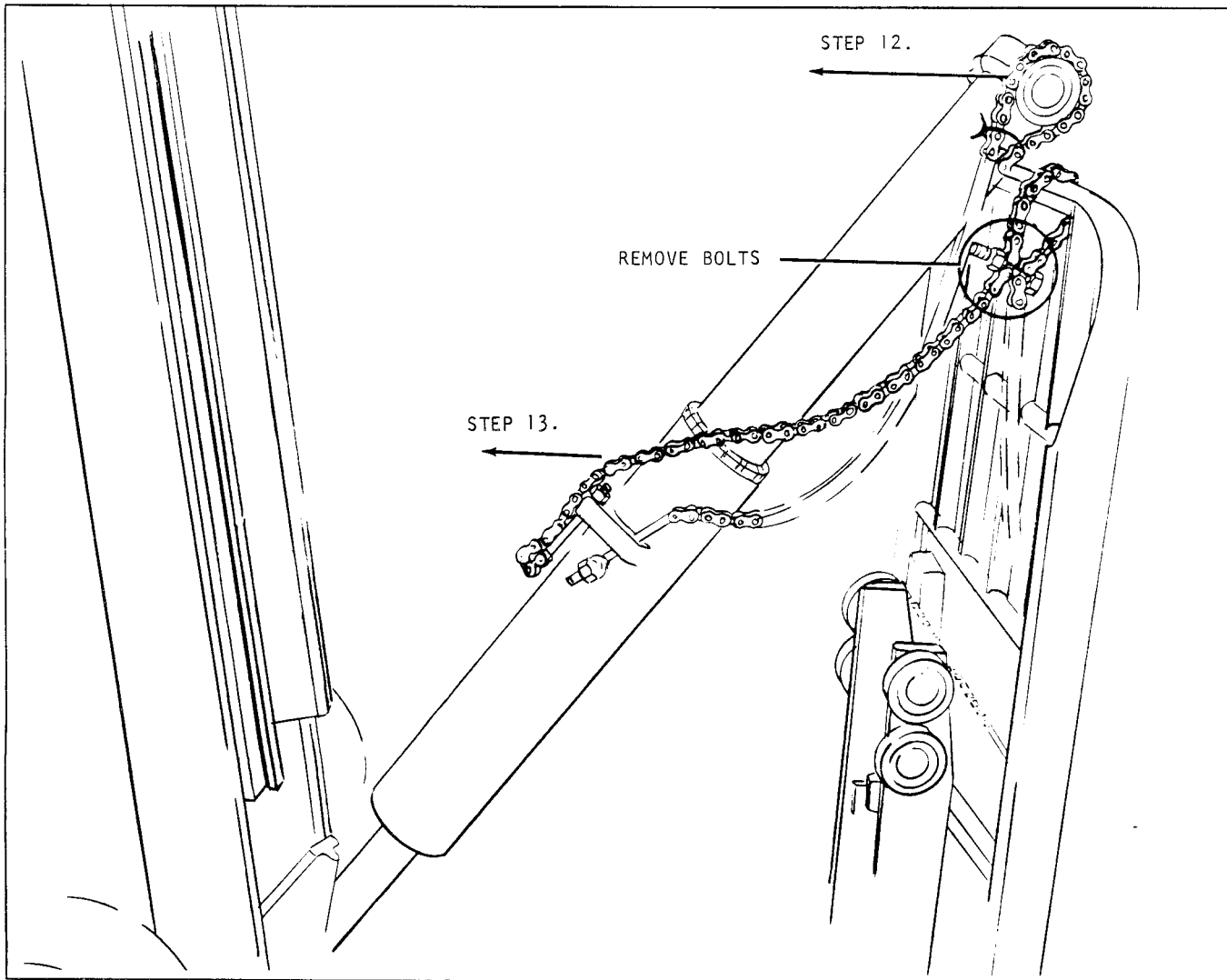

Plate 9656 Cylinder Replacement

Step 12. Using chain hoist, place cylinder back between rails.

N O T E

When installing cylinder watch position of cylinder line and tube, to prevent damage.

Step 13. Pull rear lift chains through back of upright.

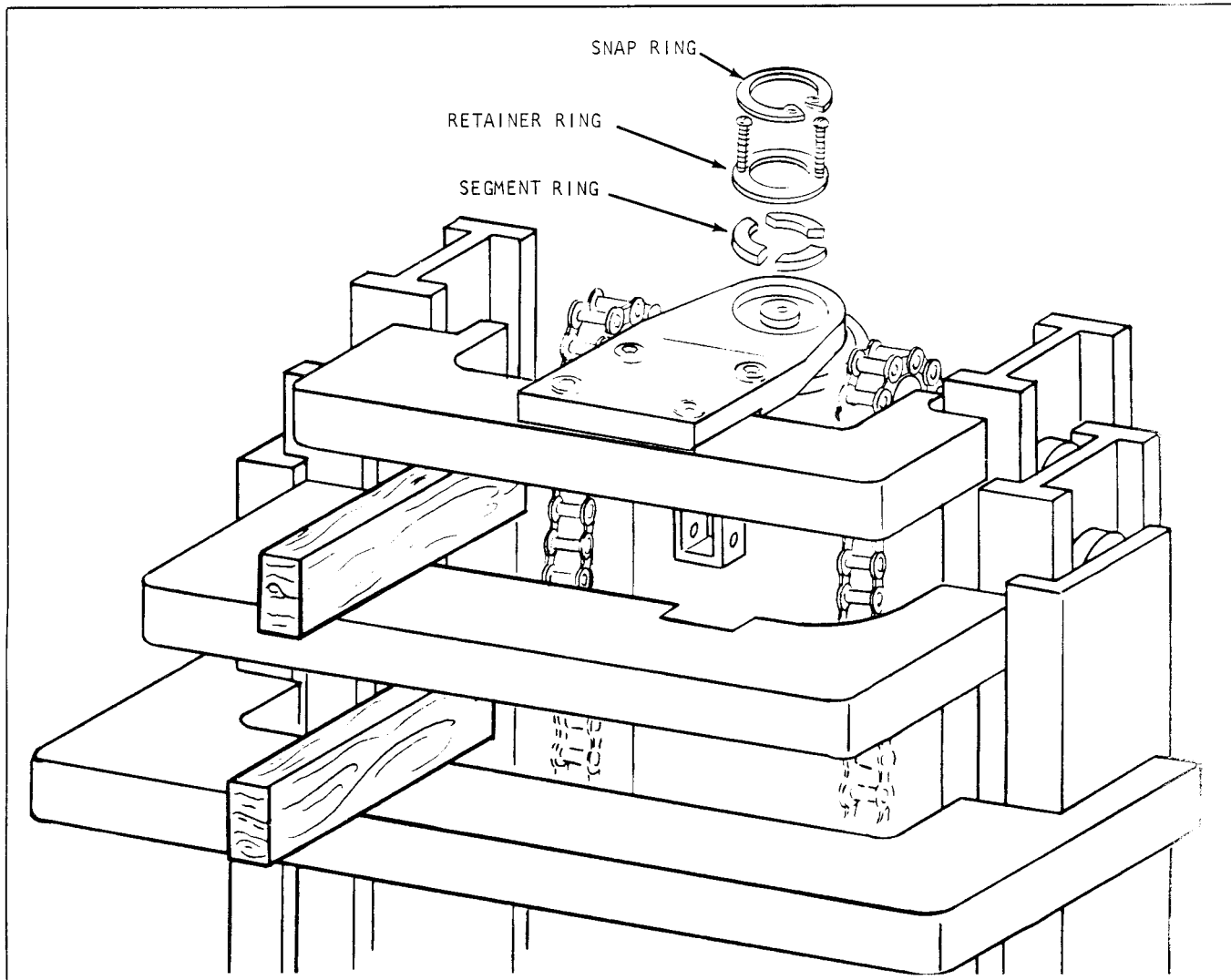

Plate 9657 Piston Head F.F.T.

Step 14(a). Install segment ring.

(b). Install retainer ring and remove both slotted machine screws.

(c). Install snap ring.

(d). Raise and lower to full positions checking piston and anchor. Remove blocks between tie bars.

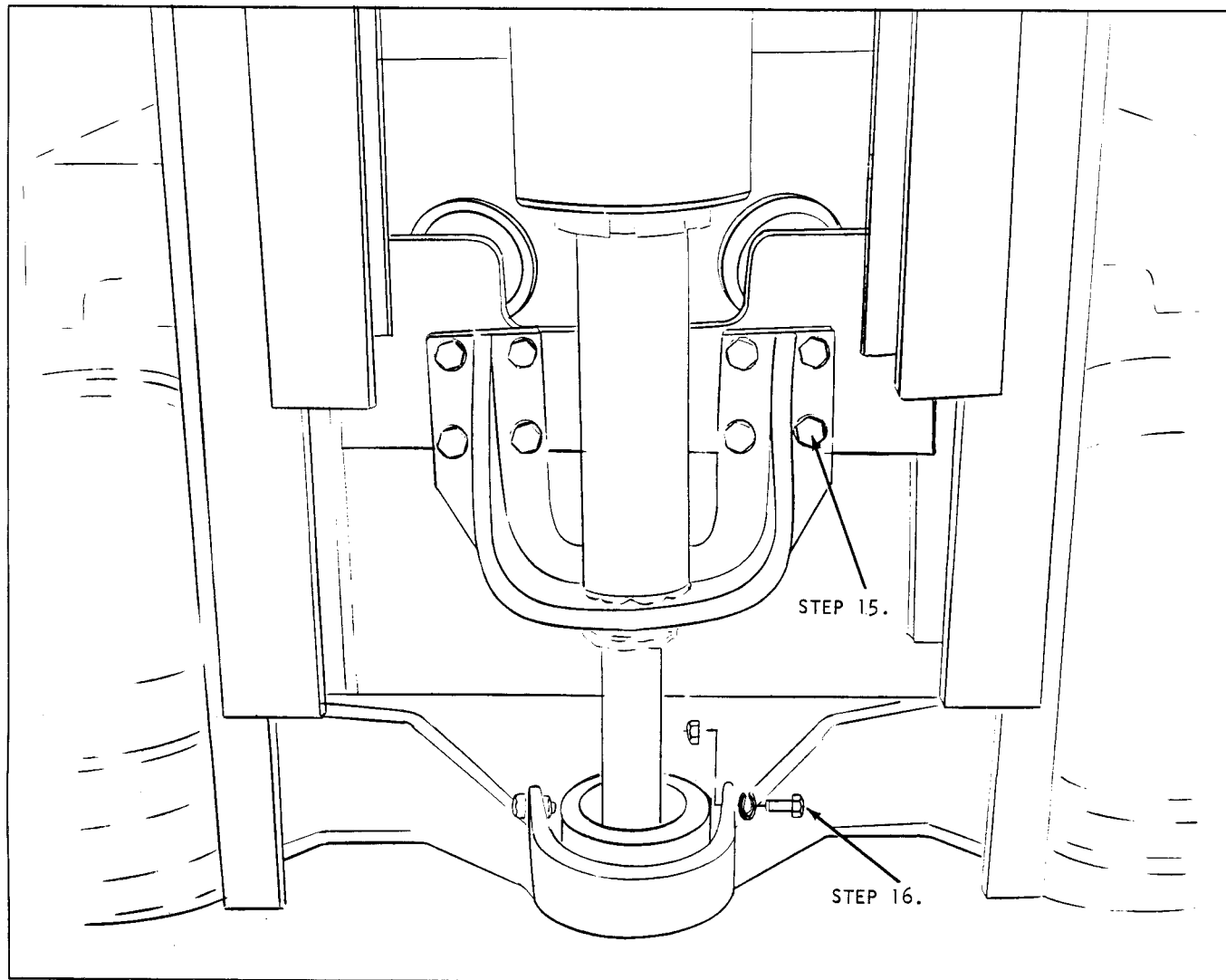

Plate 9658 Cylinder Lift Bracket

Step 15. Install cylinder lifting bracket.

Step 16. Install lift cylinder support bolts.

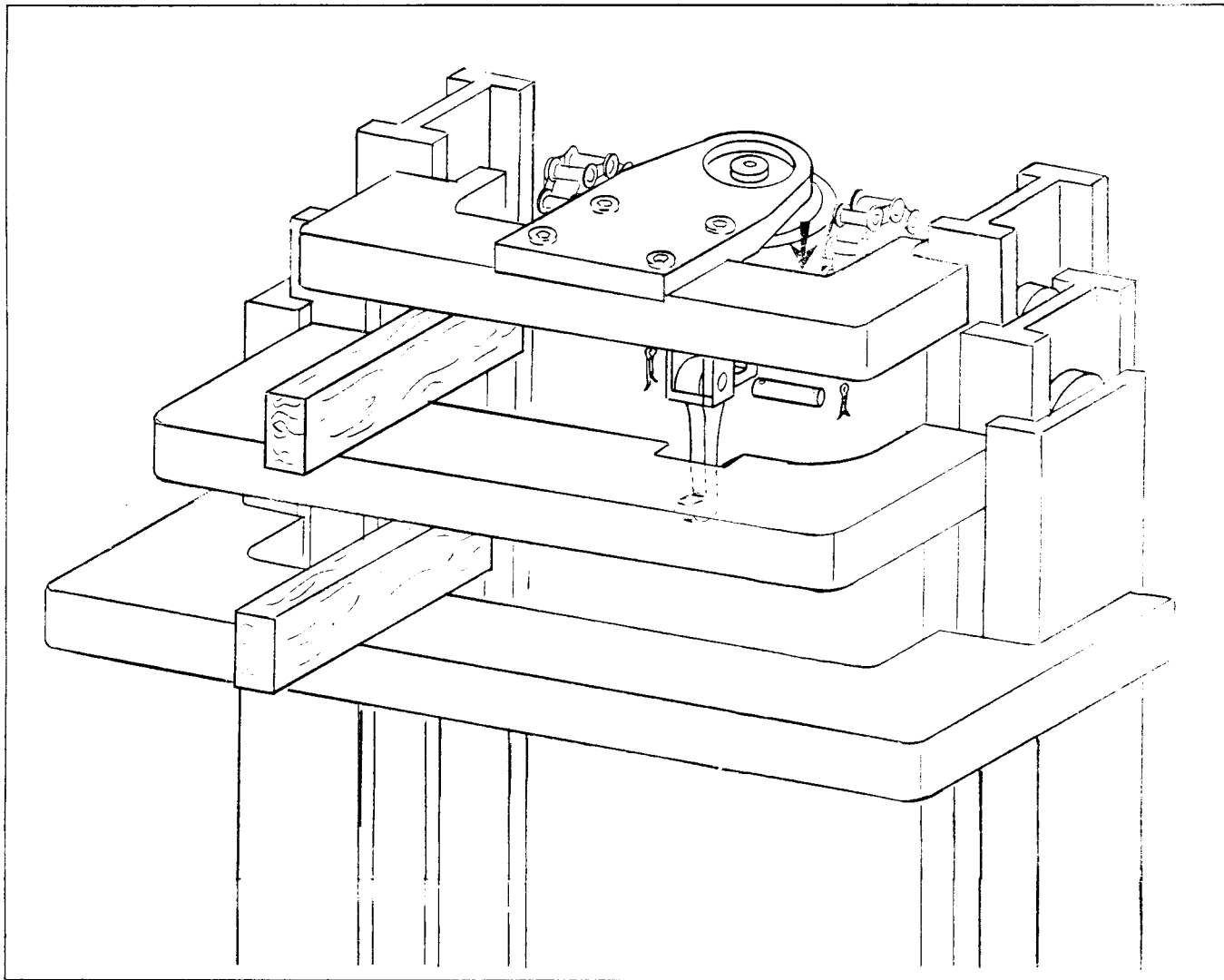

Plate 9659 Safety Stop

Step 17. Pull piston head down.

Install mechanical safety stop.

Replace cotter keys.

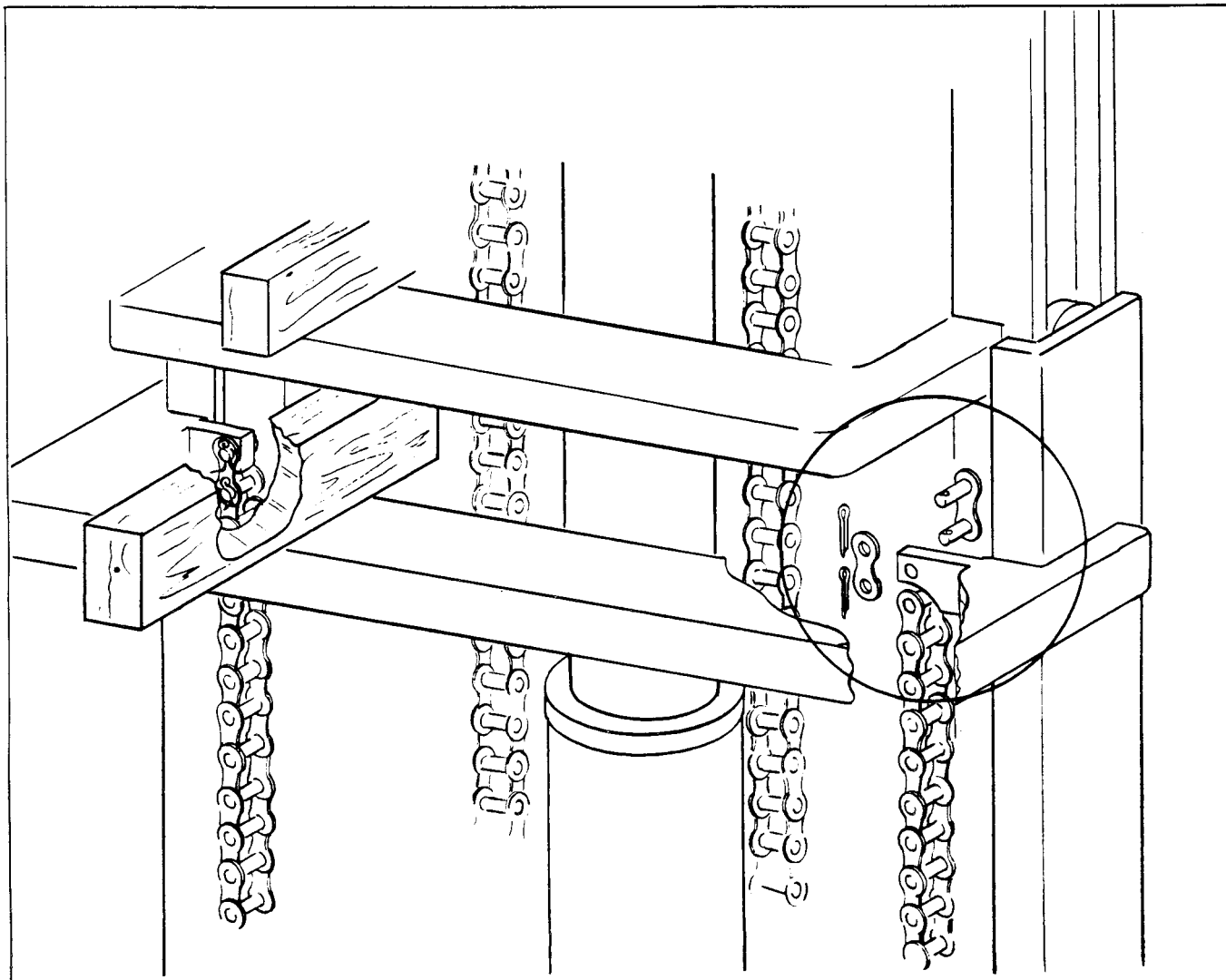

Plate 9660 Replacing Rear Lift Chains

Step 18. Install rear lift chains.

Check chain tension for adjustment. If adjustment is necessary be sure to secure adjusting nuts before operating machine.



INDUSTRIAL TRUCK DIVISION



TROUBLE SHOOTING GUIDE

ENGINE

TROUBLE	PROBABLE CAUSE	REMEDY
Starting motor will not crank engine.	<p>Battery discharged</p> <p>Battery cable terminals loose or corroded. Ignition Fuse blown.</p> <p>Starting motor drive gear jammed in flywheel teeth.</p> <p>Improper oil.</p> <p>Battery cable terminal broken.</p> <p>Poor starting switch contacts.</p> <p>Faulty Neutral Starting Switch.</p>	<p>Recharge or replace battery.</p> <p>Remove and clean, reinstall and tighten cables. Replace fuse.</p> <p>Loosen starting motor and free-up gear.</p> <p>Change oil to proper grade.</p> <p>Replace cable.</p> <p>Replace switch.</p> <p>Refer to Starting Motor.</p>
Starting motor operates, but fails to crank engine when switch is engaged.	<p>Starting motor gear does not engage flywheel.</p> <p>Starting motor or drive gear defective.</p>	<p>Remove starting motor, and clean drive mechanism.</p> <p>Replace starting motor.</p>
<u>Engine will not start.</u> No spark. Ammeter shows no discharge (Zero reading) with ignition switch "on".	<p>Ignition switch partly "on".</p> <p>Ignition switch defective.</p> <p>Ignition primary wires or starting motor cables broken or connections loose.</p> <p>Ignition coil primary winding open.</p> <p>Distributor points dirty.</p> <p>Distributor points not closing.</p> <p>Loose or corroded ground, or battery cable connections.</p>	<p>Turn switch "on" fully.</p> <p>Replace switch.</p> <p>Repair, or replace and tighten.</p> <p>Replace coil.</p> <p>Clean and adjust points.</p> <p>Adjust or replace points.</p> <p>Remove and clean, reinstall and tighten cables.</p>
<u>Engine will not start.</u> Ammeter showing abnormal discharge with ignition switch "on".	<p>Defective condenser.</p> <p>Short-circuited or burned distributor cap or rotor.</p> <p>Short-circuited wire between ammeter and ignition switch.</p> <p>Short-circuited primary winding in ignition coil.</p> <p>Distributor points not opening.</p>	<p>Replace condenser.</p> <p>Replace parts.</p> <p>Repair or replace wire.</p> <p>Replace coil.</p> <p>Clean or replace, and adjust points.</p>
Weak spark.	<p>Distributor points pitted or burned.</p> <p>Distributor condenser weak.</p> <p>Ignition coil weak.</p>	<p>Clean or replace, and adjust points.</p> <p>Replace condenser.</p> <p>Replace coil.</p>



INDUSTRIAL TRUCK DIVISION



TROUBLE SHOOTING GUIDE

ENGINE (Continued)

TROUBLE	PROBABLE CAUSE	REMEDY
<p><u>Engine will not start.</u> Weak spark (continued)</p>	<p>Primary wire connections loose.</p> <p>High-tension, spark plug wires, or distributor cap wet.</p> <p>High-tension, spark plug wires, or distributor cap damaged.</p> <p>Distributor cap or rotor burned or broken.</p> <p>Spark plug gap incorrect.</p> <p>Short-circuited secondary circuit in coil.</p>	<p>Tighten.</p> <p>Dry thoroughly.</p> <p>Replace defective parts.</p> <p>Replace defective parts.</p> <p>Reset gaps.</p> <p>Replace coil.</p>
<p>Good spark.</p>	<p>Fuel tank empty.</p> <p>Dirt or water in carburetor, or float stuck.</p> <p>Carburetor and engine flooded by excessive use of choke.</p> <p>Fuel does not reach carburetor.</p> <p>Dirt in fuel lines or tank.</p> <p>Fuel line pinched.</p> <p>Ignition wires incorrectly installed in distributor cap.</p> <p>Ignition timing incorrect.</p> <p>Fuel Strainer Clogged.</p> <p>Fuel pump does not pump.</p> <p>Lack of engine compression.</p>	<p>Refill tank.</p> <p>Drain and clean carburetor.</p> <p>Depress accelerator pedal fully, crank engine with starting motor, when engine starts, reset throttle and leave choke control "in".</p> <p>Inspect for damaged or leaky lines or air leak into line between tank and fuel pump.</p> <p>Disconnect lines, drain tank, and blow out lines.</p> <p>Repair or replace line.</p> <p>Install wires correctly.</p> <p>Reset timing.</p> <p>Remove and clean strainer.</p> <p>Clean screen, replace pump if defective.</p> <p>Report to designated individual in authority.</p>
<p>Backfiring.</p>	<p>Ignition out of time.</p> <p>Spark plug wires incorrectly installed distributor cap or at spark plugs.</p> <p>Distributor cap cracked or shorted.</p> <p>Valve holding open.</p>	<p>Reset timing.</p> <p>Install wires correctly.</p> <p>Replace cap.</p> <p>Report to designated individual in authority.</p>



INDUSTRIAL TRUCK DIVISION



TROUBLE SHOOTING GUIDE

ENGINE (Continued)

TROUBLE	PROBABLE CAUSE	REMEDY
<p>Engine operates, but backfires and spits.</p>	<p>Improper ignition timing.</p> <p>Spark plug wires incorrectly installed in distributor cap.</p> <p>Dirt or water in carburetor.</p> <p>Carburetor improperly adjusted.</p> <p>Carburetor float level low.</p> <p>Valve sticking or not seating properly, burned or pitted.</p> <p>Excessive carbon in cylinders.</p> <p>Valve springs weak.</p> <p>Heat control valve not operating.</p> <p>Fuel pump pressure low.</p> <p>Fuel strainer clogged.</p> <p>Partly clogged or pinched fuel lines.</p> <p>Intake manifold leak.</p> <p>Distributor cap cracked or shorted.</p>	<p>Reset timing.</p> <p>Install wires correctly.</p> <p>Drain and clean carburetor.</p> <p>Clean and adjust carburetor.</p> <p>Report to designated individual authority.</p> <p>Report to designated individual authority.</p> <p>Remove carbon from cylinders.</p> <p>Report to designated individual in authority.</p> <p>Free-up, and adjust valve.</p> <p>Clean screen; replace pump, if defective.</p> <p>Remove and clean strainer.</p> <p>Clean and repair lines.</p> <p>Inspect gaskets and tighten manifold stud nuts.</p> <p>Replace cap.</p>
<p>Engine stalls on idle.</p>	<p>Carburetor throttle valve closes too far, or idle mixture incorrect.</p> <p>Carburetor choke valve remains closed.</p> <p>Dirt or water in idler passages of Carburetor.</p> <p>Air leak at intake manifold.</p> <p>Heat control valve defective.</p> <p>Spark plugs defective, gaps incorrect.</p> <p>Ignition timing early.</p> <p>Low compression.</p> <p>Water leak in cylinder head or head gaskets.</p>	<p>Adjust carburetor.</p> <p>Free-up and lubricate valve.</p> <p>Clean or replace carburetor.</p> <p>Inspect gaskets and tighten manifold stud nuts.</p> <p>Free-up and adjust valve.</p> <p>Clean or replace spark plugs, set gap clearance.</p> <p>Reset timing.</p> <p>Report to designated individual in authority.</p> <p>Replace gasket; report cylinder head leak to designated individual in authority.</p>



INDUSTRIAL TRUCK DIVISION



TROUBLE SHOOTING GUIDE

ENGINE (Continued)

TROUBLE	PROBABLE CAUSE	REMEDY
Engine misfires on one or more cylinders.	<p>Dirty spark plugs.</p> <p>Spark plug gap incorrect.</p> <p>Cracked spark plug porcelain.</p> <p>Spark plug wires grounded.</p> <p>Spark plug wires incorrectly installed in cap or at spark plugs.</p> <p>Distributor cap or rotor burned or broken.</p> <p>Valve tappet holding valve open.</p> <p>Low engine compression.</p> <p>Leaky cylinder head gasket.</p> <p>Cracked cylinder block, broken valve tappet or tappet screw.</p>	<p>Clean, adjust, or replace plugs.</p> <p>Reset gap.</p> <p>Replace spark plug.</p> <p>Replace wires.</p> <p>Install wires correctly.</p> <p>Replace defective parts.</p> <p>Report to designated individual in authority.</p> <p>Report to designated individual in authority.</p> <p>Replace gasket.</p> <p>Report to designated individual in authority.</p>
Engine does not idle properly.	<p>Ignition timing.</p> <p>Dirty spark plugs, or gaps too close.</p>	<p>Reset timing.</p> <p>Clean and adjust spark plugs.</p>
Engine misses at high speeds.	<p>Ignition coil or condenser weak.</p> <p>Distributor points sticking, dirty or improperly adjusted.</p> <p>Distributor rotor or cap cracked or burned.</p> <p>Leaky cylinder head gaskets.</p> <p>Uneven cylinder compression.</p> <p>High-tension or spark plug wires leaky, cracked insulation.</p> <p>Carburetor choke not adjusted.</p> <p>Carburetor accelerating pump system defective, dirt in metering jets or float level incorrect.</p> <p>Fuel pump defective, causing lack of fuel.</p> <p>Air cleaner dirty.</p> <p>Heat control valve defective.</p>	<p>Replace defective parts.</p> <p>Clean, adjust, or replace points.</p> <p>Replace defective parts.</p> <p>Replace gaskets.</p> <p>Report to designated individual in authority.</p> <p>Replace defective parts.</p> <p>Adjust choke.</p> <p>Report to designated individual in authority.</p> <p>Clean screen, replace defective pump.</p> <p>Clean complete air cleaner and refill oil cup.</p> <p>Free-up and adjust</p>



INDUSTRIAL TRUCK DIVISION



TROUBLE SHOOTING GUIDE

ENGINE (Continued)

TROUBLE	PROBABLE CAUSE	REMEDY
Engine misses at high speeds. (continued)	<p>Valves sticking, weak or broken valve springs.</p> <p>Fuel strainer clogged.</p> <p>Weak distributor bracket arm spring</p> <p>Excessive play in distributor shaft bearing.</p> <p>Spark plugs defective, dirty or gap incorrectly set.</p>	<p>Report to designated individual in authority.</p> <p>Remove and clean strainer.</p> <p>Replace point set.</p> <p>Replace distributor.</p> <p>Clean, adjust or replace spark plugs.</p>
Engine pings (Spark Knock).	<p>Ignition timing early.</p> <p>Distributor automatic spark advance stuck in advance position, or spring broken.</p> <p>Excessive carbon deposit in cylinders.</p> <p>Incorrect fuel.</p>	<p>Reset timing.</p> <p>Replace distributor.</p> <p>Remove cylinder head and clean.</p> <p>Drain, use correct fuel.</p>
Engine lacks power.	<p>Ignition timing late.</p> <p>Incorrect fuel.</p> <p>Leaky cylinder head gasket.</p> <p>Excessive carbon formation.</p> <p>Engine runs cold.</p> <p>Insufficient oil, or improper grade oil.</p> <p>Oil system failure.</p> <p>Air Cleaner dirty.</p> <p>Spark plug gaps too wide.</p> <p>Choke valve partially closed, or throttle does not open fully.</p> <p>Manifold heat control inoperative.</p> <p>Exhaust pipe, muffler or tail pipe obstructed.</p> <p>Low compression, broken valve springs, sticking valves.</p>	<p>Reset timing.</p> <p>Use correct fuel.</p> <p>Replace gasket.</p> <p>Remove cylinder head, and clean cylinder head, piston heads, cylinder block, and valves.</p> <p>Test thermostat; in cold weather, cover radiator.</p> <p>Lubricate in accordance with lubrication section.</p> <p>Report to designated individual in authority.</p> <p>Clean complete air cleaner, change oil in cup.</p> <p>Reset gaps.</p> <p>Adjust valve or throttle.</p> <p>Free-up and adjust control.</p> <p>Service or replace obstructed parts.</p> <p>Report to designated individual in authority.</p>



INDUSTRIAL TRUCK DIVISION



TROUBLE SHOOTING GUIDE

ENGINE (Continued)

TROUBLE	PROBABLE CAUSE	REMEDY
Engine lacks power. (Continued)	Improper tappet adjustment. Lack of fuel.	Adjust tappets. Clean filter, inspect fuel pump, inspect carburetor for water or dirt and clean if necessary.
Engine overheats.	Cooling system deficient. Water low, air flow through radiator core restricted. Clogged radiator core (Clogged internally). Cylinder head gasket leaking. Radiator or water pump leaking. Damaged or deteriorated hose or fan belt. Loose fan belt. Cylinder block or head leaking. Ignition timing incorrect. Damaged muffler, bent or clogged exhaust pipe. Excessive carbon in cylinders. Insufficient oil, or improper grade. Air Cleaner restricted. Inoperative thermostat. Water pump impeller broken. Poor compression. Valve timing incorrect.	Clean radiator core from engine side with compressed air or water, or fill radiator to proper level. Clean by flushing radiator. Tighten cylinder head stud nuts and/or replace gasket. Repair or replace defective parts. Replace defective parts. Adjust fan belt tension. Report to designated individual in authority. Reset timing. Service or replace defective parts. Remove cylinder head, and clean cylinder head, piston heads cylinder block, and valves. Refer to Lubrication Instructions. Clean complete change oil in cup. Replace thermostat and gasket. Replace pump. Report to designated individual in authority. Reset timing.
High fuel consumption.	High engine speeds (Excessive driving in lower gear range). Air cleaner clogged. Carburetor float level too high, accelerating pump not properly adjusted. Fuel line leaks.	Correct driving practice. Clean complete air cleaner and change oil in cup. Report to designated individual in authority. Correct leaks, replace lines.



INDUSTRIAL TRUCK DIVISION



TROUBLE SHOOTING GUIDE

ENGINE (Continued)

TROUBLE	PROBABLE CAUSE	REMEDY
High fuel consumption. (Continued)	Overheated engine. Carburetor parts worn or broken. Fuel pump pressure too high, or leaky diaphragm. Engine running cold. Ignition incorrectly timed. Spark advance stuck. Leaking fuel pump bowl gasket. Low compression. Carburetor controls sticking. Engine idles too fast. Spark plugs dirty. Weak coil or condenser Clogged muffler, or bent exhaust pipe. Loose engine mounts, permitting engine to shake and raise fuel level in carburetor.	See "Engine overheats". Replace fuel carburetor. Replace fuel pump. Inspect thermostat, cover radiator in winter. Reset timing. Replace distributor. Replace gasket. Report to designated individual in authority. Free-up and lubricate controls. Adjust carburetor throttle stop screw. Clean or replace spark plugs. Replace coil or condenser. Service or replace defective parts. Tighten; if damaged, replace defective mounts.
High oil consumption.	High engine speeds, or excessive driving in low gear range. Oil leaks. Improper grade oil, or diluted oil. Overheating of engine causing thinning of oil. Oil filter clogged. Defective piston or rings, excessive side clearance of intake valves in guides, cylinder bores worn (scored, out-of-round, tapered); excessive bearing clearance, misaligned connecting rods.	Correct driving practice. Replace leaking gaskets. Use new oil of proper grade. See "Engine overheats". Clean filter case thoroughly and replace element. Report to designated individual in authority.



INDUSTRIAL TRUCK DIVISION



TROUBLE SHOOTING GUIDE

ENGINE (Continued)

TROUBLE	PROBABLE CAUSE	REMEDY
Low oil pressure.	<p>Insufficient oil supply.</p> <p>Improper grade of oil, or diluted oil foaming at high speeds.</p> <p>Oil too heavy (funneling in cold weather).</p> <p>Oil pump screen clogged.</p> <p>Oil leaks.</p> <p>Faulty oil pump, pressure regulator valve stuck or improperly adjusted, or spring broken.</p>	<p>Fill crankcase to prescribed level.</p> <p>Change oil, inspect crankcase ventilator, inspect for water in oil.</p> <p>Change to proper grade oil. (Refer to Lubrication Instructions.</p> <p>Remove oil pan and clean pump screen.</p> <p>Report to designated individual in authority.</p> <p>Report to designated individual in authority.</p>
Defective valves.	<p>Incorrect tappet adjustment.</p> <p>Other valve troubles.</p>	<p>Adjust tappets.</p> <p>Report to designated individual in authority.</p>
Abnormal engine noises.	<p>Loose fan, fan pulley or belt, heat control valve.</p> <p>Leaking intake or exhaust manifold or gaskets, cylinder head gasket, or spark plugs.</p> <p>Overheated engine, clogged exhaust system.</p> <p>Other abnormal engine noises.</p>	<p>Tighten or correct conditions as required.</p> <p>Tighten loose components or replace defective gaskets.</p> <p>Remove obstruction from exhaust system. Inspect for further serviceability.</p> <p>Report to designated individual in authority.</p>
Poor compression.	<p>Incorrect tappet adjustment.</p> <p>Leaking, sticking, or burned valves; sticking tappets; valve spring weak or broken; valve stems and guides worn; piston ring grooves worn or rings worn, broken, or stuck; cylinder bores scored or worn.</p>	<p>Adjust tappets.</p> <p>Report to designated individual in authority.</p>



INDUSTRIAL TRUCK DIVISION



TROUBLE SHOOTING GUIDE

FUEL SYSTEM

TROUBLE	PROBABLE CAUSE	REMEDY
Fuel does not reach carburetor.	No fuel in fuel tank. Fuel pump inoperative. Fuel line air leak between tank and fuel pump. Fuel line clogged. Fuel tank cap vent clogged.	Fill fuel tank. Replace pump. Repair or replace line. Disconnect and blow out lines. Clean vent.
Fuel reaches carburetor, but does not reach cylinders.	Choke does not close. Fuel passage in carburetor clogged. Carburetor float valve stuck closed.	Free-up and lubricate, inspect for proper operation. Clean or replace carburetor. Report to designated individual in authority.
High fuel consumption.	Lubricant in power train too heavy. Incorrect adjustment of carburetor. Vehicle overloaded. Tires improperly inflated. Tight brakes.	Use correct lubricant. Adjust carburetor. Reduce loads to specified maximum capacity. Inflate tires properly. Adjust brakes.
Low fuel pressure.	Air leak in fuel lines. Fuel pump defective, diaphragm broken; valves leaking, linkage worn. Fuel lines clogged.	Tighten connections, repair lines if damaged. Replace fuel pump. Clean or replace lines.
Engine idles too fast.	Improper carburetor throttle stop adjustment. Carburetor control sticking. Control return spring weak.	Adjust throttle stop screw. Free-up and lubricate control. Replace spring.
Fuel gauge does not register.	Loose wire connection at instrument panel or tank unit. Instrument panel unit or tank unit inoperative.	Tighten connections. Replace unit.



INDUSTRIAL TRUCK DIVISION



TROUBLE SHOOTING GUIDE

COOLING SYSTEM

TROUBLE	PROBABLE CAUSE	REMEDY
Overheating.	Unusual operating conditions of high temperature.	Inspect. (Refer to "Engine overheats".)
Loss of cooling solution.	Loose hose connections. Damaged or deteriorated hose. Leaking radiator.	Tighten hose connections. Replace hoses. Repair or replace radiator.
Engine operates too cool.	Thermostat sticking. Low air temperature.	Replace thermostat and gasket. Cover radiator.
Noises.	Frayed or loose fan belt. Water pump defective.	Replace or adjust belt. Replace pump.

THE ENGINE COOLING SYSTEM

Trouble spots resulting from service neglect

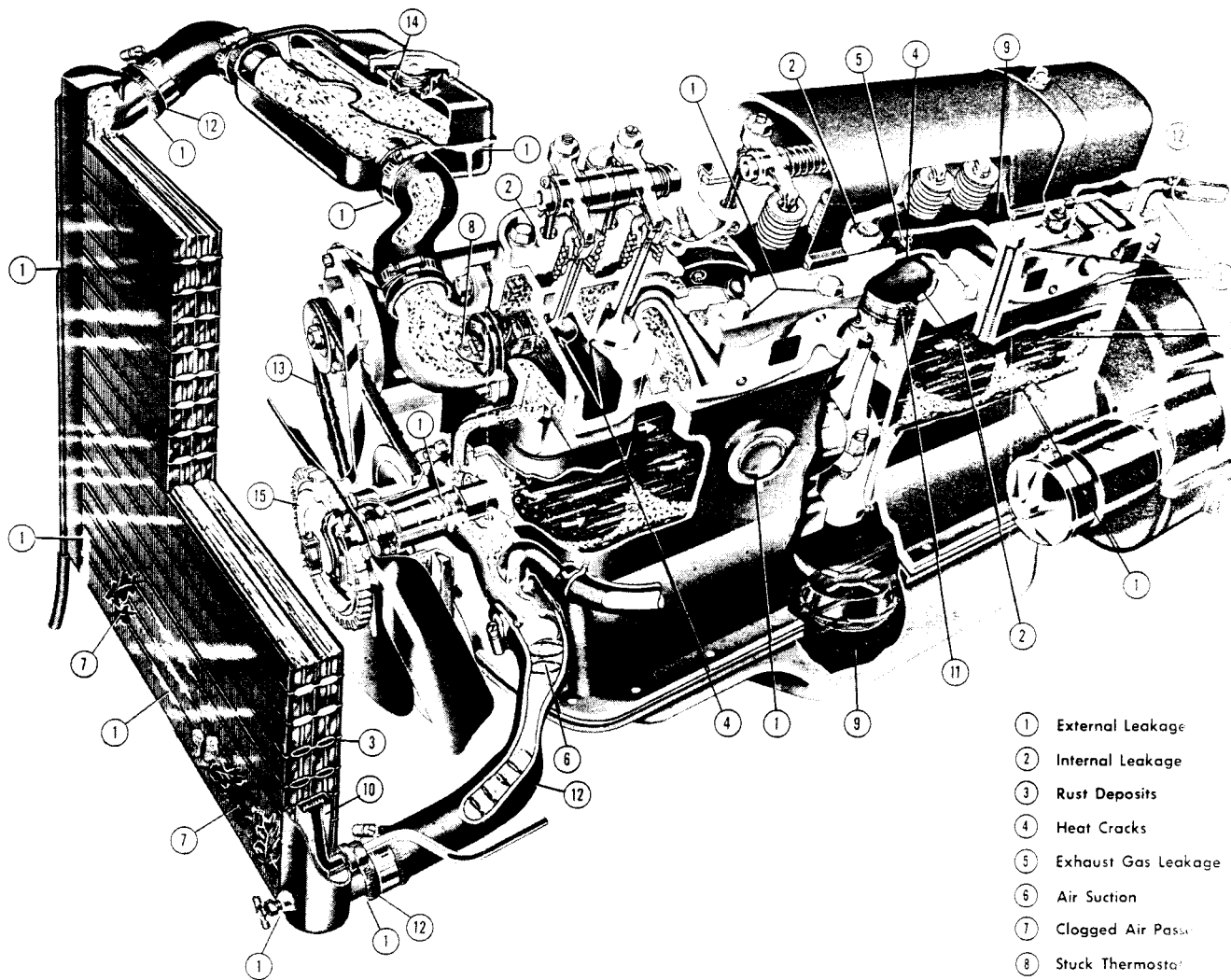

- ① External Leakage
- ② Internal Leakage
- ③ Rust Deposits
- ④ Heat Cracks
- ⑤ Exhaust Gas Leakage
- ⑥ Air Suction
- ⑦ Clogged Air Passages
- ⑧ Stuck Thermostat
- ⑨ Sludge Formation in Oil
- ⑩ Transmission Oil Leaking
- ⑪ Heat Damage
- ⑫ Hose Failure
- ⑬ Worn Fan Belt
- ⑭ Pressure Cap Leakage
- ⑮ Temperature Control Fan Drive

The cooling system depicted here does not represent that of any particular make of car; it incorporates features used by many different manufacturers

All Rights Reserved. No Part of This Chart May Be Reproduced Without Permission From Union Carbide Corporation.

Cooling System Care Pays!

This chart is distributed as a public service by
UNION CARBIDE CONSUMER PRODUCTS COMPANY
UNION CARBIDE Division of Union Carbide Corporation



INDUSTRIAL TRUCK DIVISION



TROUBLE SHOOTING GUIDE

IGNITION SYSTEM

TROUBLE	PROBABLE CAUSE	REMEDY
Ignition system troubles.	<p>Weak spark.</p> <p>Timing incorrect.</p> <p>Moisture on distributor wires, coil, or spark plugs.</p> <p>Ignition switch inoperative.</p> <p>Primary or secondary wiring loose, broken, or grounded.</p> <p>Coil defective.</p> <p>Distributor defective.</p> <p>Spark plug defective.</p>	<p>Refer to "Engine will not start",</p> <p>Retime ignition.</p> <p>Clean and dry thoroughly.</p> <p>Replace switch.</p> <p>Service.</p> <p>Refer to "Ignition coil troubles", below.</p> <p>Refer to "Distributor troubles", below.</p> <p>Refer to spark plug troubles below.</p>
Ignition coil.	<p>Connections loose; dirty or broken external wire, wet.</p> <p>Coil defective.</p>	<p>Clean and tighten, or repair, if necessary, thoroughly.</p> <p>Replace coil.</p>
Distributor troubles.	<p>Distributor breaker points dirty or pitted, point gaps incorrect.</p> <p>Distributor breaker point arm spring weak.</p> <p>Distributor breaker points sticking.</p> <p>Distributor automatic advance defective.</p> <p>Distributor cap or rotor shorted, cracked or broken.</p> <p>Distributor rotor does not turn.</p> <p>Condenser defective.</p>	<p>Clean, adjust or replace breaker points.</p> <p>Replace breaker point arm.</p> <p>Free-up breaker points.</p> <p>Lubricate and free-up. If seized, replace distributor.</p> <p>Replace defective parts.</p> <p>Report to designated individual in authority.</p> <p>Replace condenser.</p>
Spark plug troubles.	<p>Cracked, broken, leaking, or improper type.</p> <p>Spark plug wires incorrectly installed on plugs or in distributor cap.</p> <p>Spark plugs dirty; gap incorrect.</p> <p>Spark plug porcelain cracked or broken.</p>	<p>Replace spark plug.</p> <p>Install wires correctly.</p> <p>Clean, set gaps, or replace plugs.</p> <p>Replace plug.</p>



INDUSTRIAL TRUCK DIVISION



TROUBLE SHOOTING GUIDE

STARTING MOTOR

TROUBLE	PROBABLE CAUSE	REMEDY
Starting motor cranks engine slowly.	<p>Engine oil too heavy.</p> <p>Battery charge low.</p> <p>Battery cell shorted.</p> <p>Battery connections corroded, broken, or loose.</p> <p>Dirty commutator.</p> <p>Insufficient brush surface contact.</p> <p>Defective starting motor.</p> <p>Starting switch defective.</p>	<p>Change to proper grade oil.</p> <p>Recharge or replace battery.</p> <p>Replace battery.</p> <p>Clean and tighten, or replace cables.</p> <p>Clean commutator.</p> <p>Free-up or replace brush.</p> <p>Replace starting motor.</p> <p>Replace switch.</p>
Starting motor does not crank engine.	<p>Engine oil too heavy.</p> <p>Starting motor, Solenoid, or cables defective; loose connections.</p> <p>Starting motor pinion gear jammed in flywheel drive gear.</p> <p>Dirty drive mechanism.</p> <p>Faulty Relay Switch.</p> <p>Ignition Fuse Blown.</p> <p>Faulty Ignition Switch.</p> <p>Faulty Neutral Starting Switch.</p>	<p>Change to proper grade oil.</p> <p>Replace or tighten loose connections.</p> <p>Remove starting motor and reinstall. Replace defective driving gear.</p> <p>Clean and lubricate drive mechanism.</p> <p>Replace Relay Switch.</p> <p>Replace Fuse.</p> <p>Replace Switch.</p> <p>Replace Switch.</p> <p>NOTE: The INDEX of this manual will list an ADJUSTMENT for Neutral Starting Switch if your machine is so equipped.</p>



INDUSTRIAL TRUCK DIVISION



TROUBLE SHOOTING GUIDE

GENERATOR TROUBLES

TROUBLE	PROBABLE CAUSE	REMEDY
No output.	Regulator defective.	Replace regulator.
Low or fluctuating output.	Loose fan belt. Insufficient brush surface contact. Weak brush springs. Worn commutator. Broken or loose connections. Dirty commutator. Regulator defective. Loose or dirty connections in charging circuit.	Adjust belt. Free-up or replace brush. Replace spring. Report to designated individual in authority. Repair, tighten or replace. Clean commutator. Replace regulator. Clean and tighten connections.
Excessive output.	Short circuit between field coil and armature leads. Regulator defective.	Replace generator. Replace regulator.
Noisy.	Loose pulley or generator mounting. Defective bearings, or armature rubbing on field poles. Improperly seated brushes.	Tighten. Replace generator. Seat brushes.
Generator regulator troubles.	Loose connections or mountings. Defective regulator.	Clean and tighten. Replace regulator.



INDUSTRIAL TRUCK DIVISION



TROUBLE SHOOTING GUIDE

BATTERY, LIGHTS AND HORN

TROUBLE	PROBABLE CAUSE	REMEDY
Battery discharged.	<p>Battery solution level low.</p> <p>Short in battery cell.</p> <p>Generator not charging.</p> <p>Loose or dirty connections; broken cables.</p> <p>Excessive use of starting motor.</p> <p>Idle battery, or excessive use of lights with engine at idle.</p> <p>Short circuits.</p>	<p>Add distilled water to bring level above plates; inspect for cracked case.</p> <p>Replace battery.</p> <p>Inspect generator, fan belt and regulator.</p> <p>Clean and tighten connections; replace cables.</p> <p>Tune up engine; charge battery.</p> <p>Recharge or replace battery. Use lights sparingly.</p> <p>Replace defective wiring.</p>
Battery (other troubles)	<p>Overheated battery.</p> <p>Case bulged (or out of shape).</p>	<p>Inspect for short circuit or excessive generator charge.</p> <p>Inspect for overcharging and over-tightening of hold-down screws.</p>
Light switch.	<p>Loose or dirty connections; broken wire.</p> <p>Defective switch.</p>	<p>Clean and tighten; replace broken wire.</p> <p>Replace switch.</p>
Wiring.	<p>Loose or dirty connections; broken wire or terminal.</p>	<p>Clean, tighten, repair or replace wire or terminal.</p>
Lights do not light.	<p>Switch not fully "on".</p> <p>Loose or dirty connections; broken wire.</p> <p>Wiring circuit short-circuited, or open.</p> <p>Light burned out.</p>	<p>Turn switch "on" fully.</p> <p>Clean and tighten; replace or repair wire or terminal.</p> <p>Correct short circuit or replace defective parts.</p> <p>Replace light.</p>
Lights dim.	<p>Loose or dirty connection.</p> <p>Wiring short-circuited.</p> <p>Defective switch.</p>	<p>Clean and tighten connections.</p> <p>Correct short circuit or replace defective parts.</p> <p>Replace switch.</p>



INDUSTRIAL TRUCK DIVISION



TROUBLE SHOOTING GUIDE

BATTERY, LIGHTS AND HORN (Continued)

TROUBLE	PROBABLE CAUSE	REMEDY
Horn troubles.	Loose or dirty wiring connections.	Clean and tighten connections.
Horn sounds continuously.	Short-circuit in wiring between horn and horn button.	Replace wire.
Improper tone.	Loose or dirty wiring connections. Cover or bracket screws loose. Points adjusted improperly.	Clean and tighten connections. Tighten. Adjust points.
Horn will not operate.	Horn Fuse Blown. Open Circuit. Faulty Horn Relay.	Replace Fuse. Trace, repair or replace as required. Replace relay.



INDUSTRIAL TRUCK DIVISION



TROUBLE SHOOTING GUIDE

DRIVE AXLE

TROUBLE	PROBABLE CAUSE	REMEDY
Continuous Axle Noise.	Badly worn parts. Unevenly worn tires. Improperly adjusted wheel bearing. Lack of lubricant.	Replace worn parts with new. Replace tires. Adjust correctly. Add sufficient lubricant of correct grade.
Axle Noise on Drive or on Coast Only.	Differential pinion gear and ring gear out of adjustment or worn excessively.	Adjust, repair or replace entire unit if conditions warrants.
Excessive Backlash in Axle Driving.	Loose axle shaft drive flange cap screws. Flange loose on axle shaft. Worn splines on axle shaft at differential end. Differential drive pinion gear and ring gear out of adjustment or worn excessively.	Tighten cap screws. Reweld flange to shaft. Replace drive flange and shaft assembly. Adjust or replace as condition warrants.
Complete Failure to Function.	Broken axle shaft. Broken teeth on ring gear or pinion gear.	Replace axle shaft. Replace ring gear and pinion and other parts of differential necessary. Adjust ring gear and pinion gear correctly.



INDUSTRIAL TRUCK DIVISION



TROUBLE SHOOTING GUIDE

STEERING AXLE

TROUBLE	PROBABLE CAUSE	REMEDY
Trouble.	Damaged axle. Lubrication leaks. Incorrect caster or camber. Uneven tire wear.	Replace axle. Replace oil seals. (Refer to Lubrication Section). Report to designated individual in authority. Report to designated individual in authority. Inflate tires properly. Check wheel alignment.



INDUSTRIAL TRUCK DIVISION



TROUBLE SHOOTING GUIDE

STEERING

TROUBLE	PROBABLE CAUSE	REMEDY
Steering difficult.	Lack of lubrication Tight steering system connections. Tight steering gear; misaligned wheels. Bent steering connecting linkage or arm. Misaligned steering gear mounting.	Lubricate. Lubricate and adjust linkage. Report to designated individual in authority. Straighten or replace linkage. Adjust mounting.
Wander or weaving.	Improper toe in camber or caster (axle twisted). Steering system connections or king pin bearings not properly lubricated. Loose wheel bearings. Steering gear worn or maladjusted. Steering gear mountings loose.	Report to designated individual in authority. Lubricate. Adjust wheel bearings. Report to designated individual in authority. Tighten mounting bolts.
Low speed shimmy or wobble.	Loose steering connections. Steering gear worn, or adjustment too loose. Loose wheel bearings.	Adjust and tighten linkage. Report to designated individual in authority. Adjust wheel bearings.
Vehicle pulls to one side.	Odd size, or new and old tires on opposite wheels. Tight wheel bearings. Bent steering arm or connection.	Match tires. Adjust. Lubricate wheel bearings. Straighten or replace bent linkage.



INDUSTRIAL TRUCK DIVISION



TROUBLE SHOOTING GUIDE

BRAKES

TROUBLE	PROBABLE CAUSE	REMEDY
Brakes drag.	Improper pedal adjustment. Brake pedal return spring broken or weak. Brakes improperly adjusted. Brake shoe anchor pin tight in shoe. Brake shoe return spring broken or weak. Loose or damaged wheel bearings. Insufficient brake shoe clearance, or improper brake anchor pin adjustment. Brake backing plate loose. Grease on linings. Dirt imbedded in lining. Drums scored or rough.	Adjust brake pedal free travel. Replace spring. Adjust brakes. Free-up pin and lubricate lightly. Replace spring. Adjust or replace wheel bearings. Adjust brakes. Tighten plate. Correct grease leakage; clean or install new shoes and lining assemblies. Clean lining with wire brush. Replace drum and brake shoe and lining assemblies.
Severe brake action on light pedal pressure.	Brake shoes improperly adjusted. Grease on linings. Loose brake shoe anchor.	Adjust brakes. Correct grease leakage; clean or install new shoes and lining assemblies. Adjust and tighten.
Brake locked.	Brake pedal lacks free travel. Brakes frozen to drums (cold weather).	Adjust pedal free travel. Break loose by driving vehicle.
Brake noisy or chatters.	Brake lining worn. Grease on linings. Dirt embedded in linings. Improper or loose linings. Brake shoe or drum distorted.	Replace shoe and lining assemblies. Correct leakage; clean or replace shoe and lining assemblies. Clean lining with wire brush. Replace shoe and lining assemblies. Straighten or replace.



INDUSTRIAL TRUCK DIVISION



TROUBLE SHOOTING GUIDE

BRAKES (Continued)

TROUBLE	PROBABLE CAUSE	REMEDY
Excessive pedal travel.	Lining worn. Brake improperly adjusted. Scored brake drums.	Adjust or replace shoe and lining assemblies. Adjust brake. Repair or replace drums.
Excessive pedal pressure.	Grease on linings; worn or glazed lining. Warped brake shoes, or defective brake linings. Shoes improperly adjusted. Brake drum scored or distorted. Shoes improperly adjusted. Insufficient fluid in master cylinder.	Correct grease leakage; clean up and replace shoe and lining assemblies. Replace shoe and lining assemblies. Adjust brakes. Repair or replace drums. Adjust brakes. Fill master cylinder to within 1/4 inch of the top.
Wheel troubles.	Wheel wobbles; bent. Wheel loose on hub. Wheel out of balance. Wheel bearings run hot.	Inspect mounting on hub, spindles, and drive axle; replace defective wheel or mounting. Tighten. Balance wheel. Adjust, lubricate wheel bearings.



INDUSTRIAL TRUCK DIVISION



TROUBLE SHOOTING GUIDE

HYDRAULIC SYSTEM

TROUBLE	PROBABLE CAUSE	REMEDY
Pump not delivering oil.	<p>Wrong direction *of rotation.</p> <p>Tank oil level low.</p> <p>Oil intake pipe or suction filter plugged.</p> <p>Air leak in suction line.</p> <p>Oil viscosity too heavy to pick up prime.</p> <p>Broken pump shaft or gear.</p>	<p>Must be reversed immediately to prevent seizure and breakage of parts due to lack of oil.</p> <p>Add recommended oil.</p> <p>Replace filter cartridge. Clean strainer if so equipped.</p> <p>Will prevent priming, or cause noise and irregular action of control circuit.</p> <p>Thinner oil should be used per recommendations for given perature and service.</p> <p>Report to designated individual in authority.</p>
Pump not developing pressure.	<p>Pump not delivering oil for any of the above reasons.</p> <p>Relief valve setting not high enough.</p> <p>Relief valve sticking open.</p> <p>Leak in hydraulic control system (cylinders or valves).</p> <p>Partially clogged intake line, intake filter or restricted intake pipe.</p>	<p>Check oil circulation by watching oil in tank.</p> <p>Refer to relief valve instructions.</p> <p>Dirt under pressure adjustment valve. Refer relief valve instructions.</p> <p>Find leak and correct.</p> <p>Pump must receive intake oil freely or cavitation will take place.</p>
Pump making noise.	<p>Small air leak at pump intake piping joints.</p> <p>Air leak at pump shaft packing.</p> <p>Tank air vent plugged.</p> <p>Too high oil viscosity.</p> <p>Shaft packing worn.</p> <p>Oil filter dirty.</p>	<p>Test by pouring oil on joints while listening for change in operation. Tighten as required.</p> <p>Repair or replace.</p> <p>Must be open thru breather opening or air filter.</p> <p>Use recommended oils.</p> <p>Replace shaft packing per preceding instructions.</p> <p>Replace filter element.</p>
Forks do not lift to maximum height.	<p>Hydraulic Oil level low.</p>	<p>Fill sump tank.</p>



INDUSTRIAL TRUCK DIVISION



TROUBLE SHOOTING GUIDE

HYDRAULIC SYSTEM CONTINUED

TROUBLE	PROBABLE CAUSE	REMEDY
Lift or tilt action fails.	Loss of oil pressure.	Report to designated individual in authority.
Oil leak at top of lift cylinder assembly.	Worn or damaged lift piston seal. Scored cylinder wall. Plugged vent line.	Replace seal. Replace cylinder. Clean out vent line. Replace if collapsed.
Oil leak around piston rod at tilt cylinder.	Worn seal. Scored piston rod.	Replace seal. Replace rod and eliminate cause of scoring which may be caused by misalignment, worn bearing or foreign matter.
With load centered on lift forks load is lifted unevenly.	Lift chains out of adjustment.	Adjust chains.



INDUSTRIAL TRUCK DIVISION



TROUBLE SHOOTING GUIDE

TRANSMISSION, CONVERTER AND AXLE ADAPTOR (HYDRATORK DRIVE)

TROUBLE	PROBABLE CASE	REMEDY
Machine will not move in either direction.	<p>Parking Brake not released.</p> <p>Control Linkage not Properly adjusted.</p> <p>Oil level low.</p> <p>No oil pressure.</p>	<p>Release brake.</p> <p>Readjust linkage.</p> <p>Determine cause and correct. Fill to proper level with type "A" Automatic Transmission Fluid Armour Qualified.</p> <p>Report to designated person in authority.</p>
Machine will move in one direction only.	<p>Control linkage not adjusted.</p> <p>No oil pressure to Directional Selector. Seals and "O" Rings in Directional Selector may be defective.</p> <p>Directional Selector Discs not releasing. Discs defective. Relief hole in D.S. Drum clogged.</p>	<p>Adjust linkage.</p> <p>Report to designated person in authority.</p> <p>Report to designated person in authority.</p>
Machine moves slowly in both directions at wide open throttle.	<p>Oil level low.</p> <p>Low oil pressure. Faulty Inching Valve, Faulty Relief Valve, Faulty Pump.</p> <p>Brakes dragging.</p> <p>Clogged Sump Screen.</p>	<p>Fill to correct level and determine cause for loss of oil.</p> <p>Report to designated person in authority.</p> <p>Report to designated person in authority.</p> <p>Clean Screen.</p>
Transmission overheating.	<p>Low oil.</p> <p>Low Directional Selector pressure (check with gauge). Inching valve not functioning properly.</p> <p>Seals in selector defective.</p> <p>Regulating valve sticking open.</p> <p>Brakes Dragging.</p> <p>Clogged Sump Screen.</p>	<p>Check and fill to correct level.</p> <p>Report to designated person in authority.</p> <p>Report to designated person in authority.</p> <p>Report to designated person in authority.</p> <p>Report to designated person in authority.</p> <p>Clean Screen.</p>



INDUSTRIAL TRUCK DIVISION



TROUBLE SHOOTING GUIDE

TRANSMISSION, CONVERTER AND AXLE ADAPTOR (HYDRATORK DRIVE)

TROUBLE	PROBABLE CAUSE	REMEDY
<p>Transmission Overheating (Continued)</p>	<p>Insufficient oil to Torque Converter and Cooler.</p> <p>Cooler clogged internally stopping flow of oil.</p> <p>Bushing in Torque Converter Impeller Hub worn, allowing oil to leak out.</p> <p>Slipping Stator.</p>	<p>Report to designated person in authority.</p> <p>Clean Cooler.</p> <p>Report to designated person in authority.</p> <p>Refer to Transmission Pressure Checks</p>
<p>Machine has full power and overheats.</p>	<p>Overloading machine.</p> <p>Radiator core clogged externally.</p> <p>Pressure Regulator Valve sticking, giving low pressure.</p>	<p>Check Capacity Loads. Never overload.</p> <p>Clean Core.</p> <p>Report to designated person in authority.</p>

