



OPERATOR

INSTRUCTIONS

C300Y40(D) **GAS, LP GAS** **or Diesel Powered**

4000 LBS. (1800kg.)
5000 LBS. (2300kg.)
RATED CAPACITY

CLARK

Industrial Truck **Division**

BOOK NO. OI-381, 2nd REV.

TABLE OF CONTENTS

	Page
Foreword	1
Major Component Identification	2 & 3
Safe Operating Rules and Practices	4 thru 15
Operator's Compartment and Controls	16
Operator's "Before Operation" Checks	17 thru 32
Operating Hints	33 thru 39
Fuel and Engine Oil Recommendations	35 thru 37
Parking Procedures	40 thru 43
Tire Pressures	34
Handy Reference Data	45

FOREWORD

A large share of the total cost of most every product can be traced to handling. This includes in-plant transport, storage, freight, warehousing and final delivery. In many cases, the fork lift truck plays a key role in each of these operations.

You and your lift truck can significantly reduce these costs... or increase them. A lift truck costs thousands of dollars. Add to this the cost of operation (operator's pay, fuel, maintenance, fringe benefits, etc.) and it can easily be seen that this is an important investment for any company. The investment has now been made and it is up to you to ensure that maximum return is realized.

This manual will help the "Qualified Operator" become familiar with the lift truck's major components, its operating controls, special features and the function(s) of each.

This publication is not a training manual but rather, a guide to help the "Qualified Operator" to more safe and efficient operation of a Clark lift truck.

Operator training manuals are available through your Clark dealer.

Clark trucks are built to take hard work not abuse — they are built to be dependable, but — as with any other truck — they are only as good as the man behind the wheel and the men responsible for maintaining them.

This manual guides the operator through correct procedures for checking, starting, operating, stopping and parking the lift truck.

Read it, Study it, Keep it handy. Failure to follow the operating procedures outlined in this manual may result in serious injury to you or to others in your operating area.

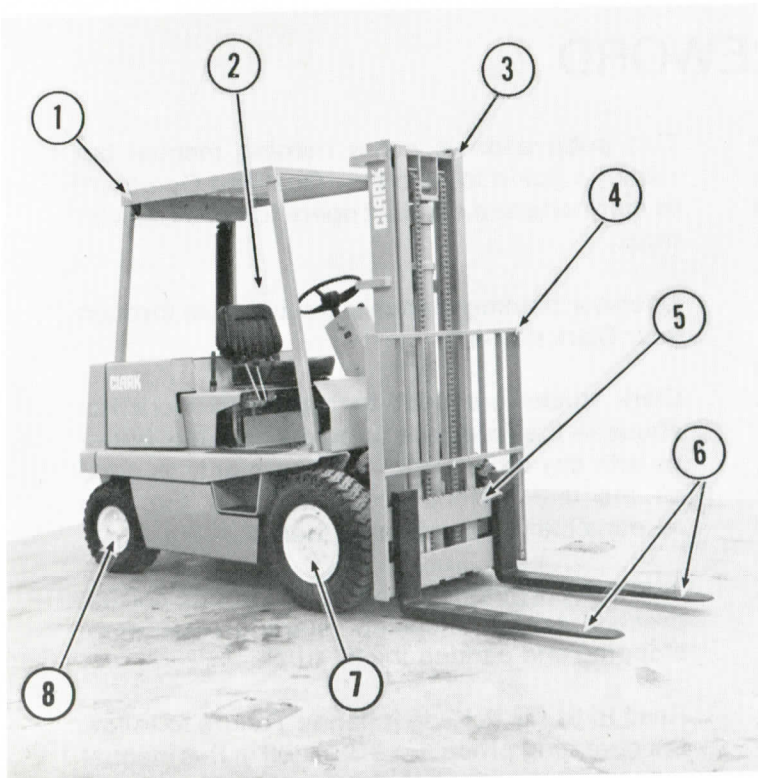

Know Your Truck

1. Overhead Guard
2. Operator's Compartment
3. Upright Assembly
4. Load Back Rest Extension
5. Lift Carriage
6. Load Forks
7. Drive Wheel and Tire
8. Steer Wheel and Tire

17526

C300Y40-50

Gas and L.P. Gas Powered
4000 Lbs. (1800 Kg) Rated Capacity
5000 Lbs. (2300 Kg) Rated Capacity
at 24 inches (600mm) Load Center.

Know Your Truck

1. Load Back Rest Extension
2. Upright Assembly
3. Operator's Compartment
4. Overhead Guard
5. Counterweight
6. Steer Wheel and Tire
7. Drive Wheel and Tire
8. Load Forks.

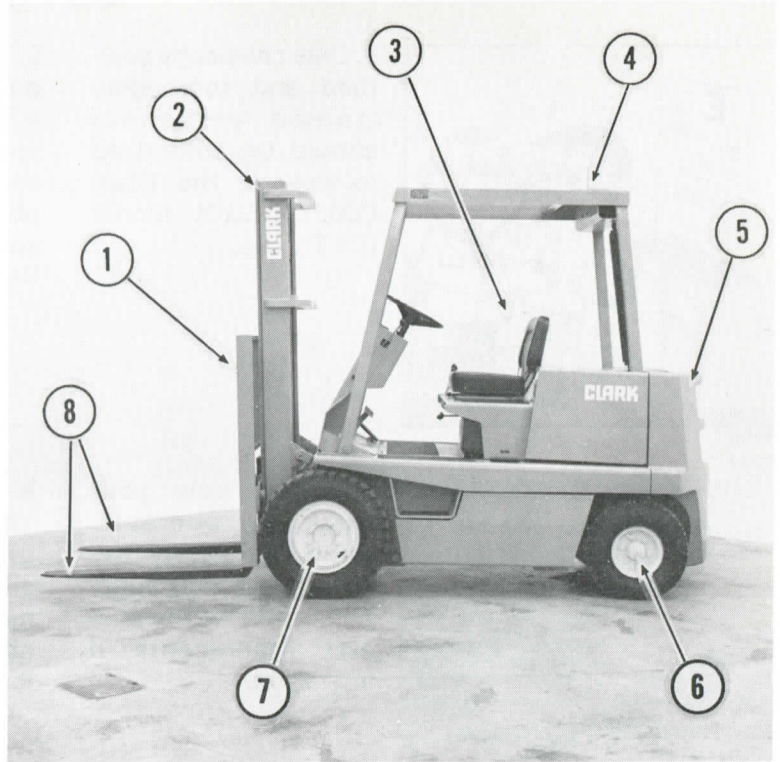

C300Y40-50

17573

Diesel Powered

4000 Lbs. (1800Kg) Rated Capacity

5000 Lbs. (2300Kg) Rated Capacity

at 24 inches (600mm) Load Center.

Safety



13696
17527

1. Only physically qualified and thoroughly trained personnel should be authorized to operate the Clark C300Y40-50(D) Model Lift Trucks.

2. Prominently placed on every Clark truck is a list of basic rules for operation. These rules are for the protection of you and others in your operating area. Be familiar with them.

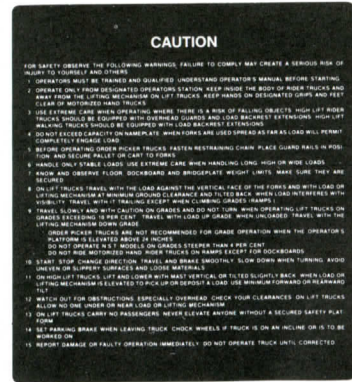

13110
17810

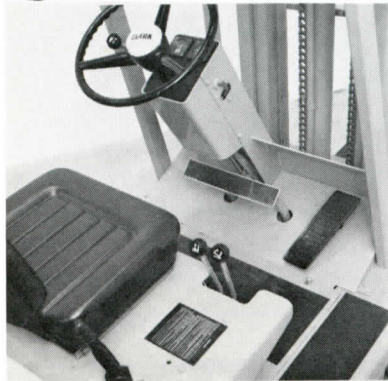

3. Learn how your truck is operated. Know its safety devices, how they function and how the special attachments, if any, work.

4. The wearing of "hard hat," safety glasses and safety shoes is recommended. Dress suitably and avoid wearing loose fitting clothing.



Safety



5. Never operate a lift truck with wet or greasy hands or shoes.

17528
17529



7. Always look all around the truck before moving it in any direction. Then remember to start and stop slowly and smoothly.

Code: OI-381 Feb. 76

6. Before operating any lift truck, test the horn, service brakes, hand brake, steering, lift-tilt controls, directional controls and any special devices for proper operation. Report any improper operation to the proper authority.

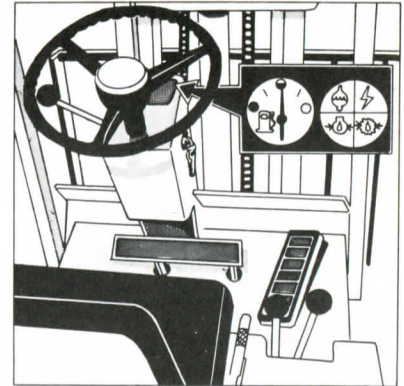

17811
17812

8. Operate the truck only in designated truck routes and keep operating aisles clear. One-way traffic is recommended. If this is not practical in your operation heed highway regulations and drive to right of aisle centerline.

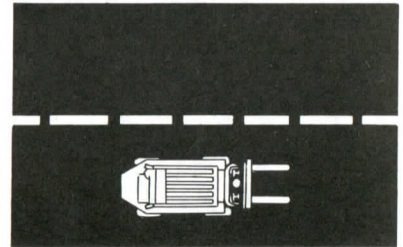
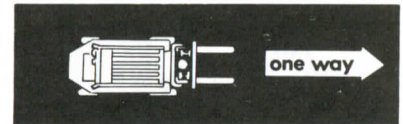

Safety

9. Be alert for pedestrians, other trucks or obstacles in your path of travel.

10. Sound horn at all corners, exits, entrances and when approaching pedestrians or bystanders.

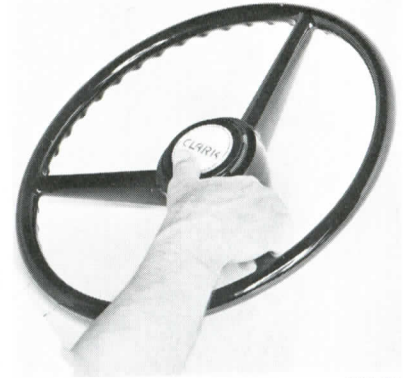

13141
17813

11. Obey all posted traffic rules and warning signs.

12. Maintain a safe distance from the truck ahead of you at all times.

Assure ample distance to stop smoothly and safely should the need arise.



17530
13087



Safety

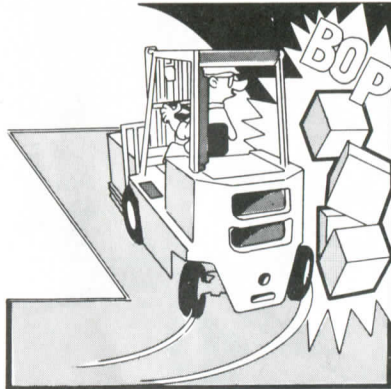

17806
17807

13. Be aware of rear end swing and be alert to prevent rear end swing damage to material in your operating area.

14. Be aware of the position of your fork tips when the truck is in motion. Be alert to prevent striking anything with fork tips.

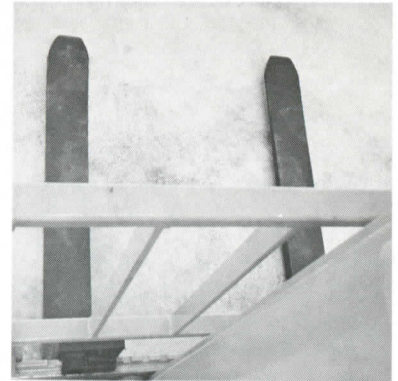

17531
13146

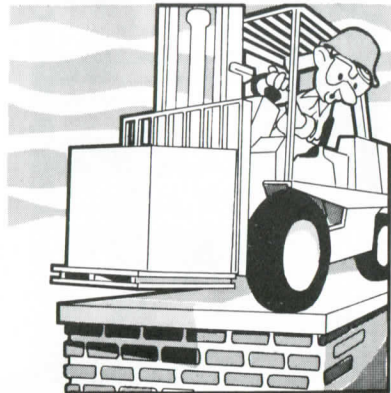

15. Be extremely cautious when operating a lift truck near the edge of a loading dock, bridge plate, embankment, ditch or ramp.

16. Make certain that vehicle being entered, loaded or unloaded has been blocked to prevent accidental roll.

Bridge plates, if used, must have adequate strength, width, guard rails, each side (minimum 3" (80mm) high recommended) and be properly secured.

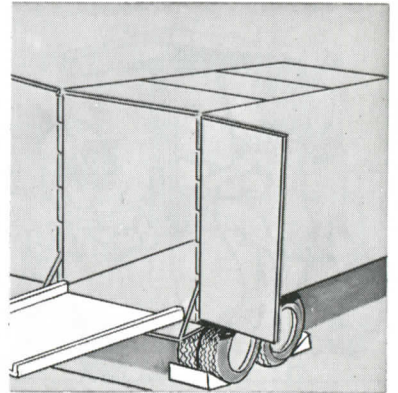

Safety



17808
17802

17. Never allow stunt riding or indulge in horseplay while operating a fork lift truck.

This is dangerous and could result in serious injury or severe damage to equipment and material.

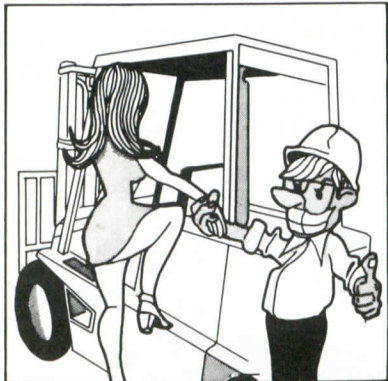

19. Never carry unauthorized passengers. The quick response of a lift truck may cause riders to fall off. Besides, they distract you and this is dangerous.

18. Never use your truck to push or tow another. Never allow your truck to be pushed or towed by another.

Should a truck become disabled and require moving, notify the proper authority immediately.

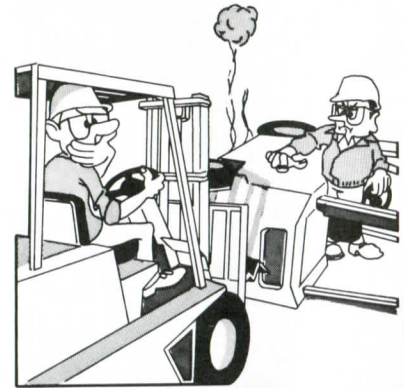

17809
13095

20. Know the capacity of your truck and its attachment (if any) and never exceed it. Study your truck data capacity plate and learn the facts stamped in areas 1 through 8.

Pay particular attention to area 3 and refer to item 46 on page 15.

CLARK EQUIPMENT		1	
INDUSTRIAL TRUCK DIVISION		BATTLE CREEK, MICHIGAN	
MODEL NO.	2	TYPE	3
SERIAL NO.	4		
ATTACHMENTS			
LOAD		CAPACITY WITH ATTACH. LISTED ABOVE	
C.G.	C	OR WITH FORKS - UPRIGHTS VERTICAL	
A	B	LES	A B C
FLOOR	B	5	
APPROX. WT. ALL TRUCKS		LESS BATT. - ELECTRICS	
APPROX. WT. ELECTRICS ONLY		WITH MAX. BATT. WT	
BATTERY WT.		MAX	7
BATTERY		AH	NO.
CAPACITY		LB	VOLTS
8			
FOR OTHER CAPACITIES CONSULT MANUFACTURER AS RELEASED FROM FACTORY THIS TRUCK MEETS THE DESIGN SPECIFICATIONS ESTABLISHED IN AMERICAN NATIONAL STANDARD FOR POWERED INDUSTRIAL TRUCKS PART II, ANSI B 56.1-1969. PT NO. 2315709			

Safety

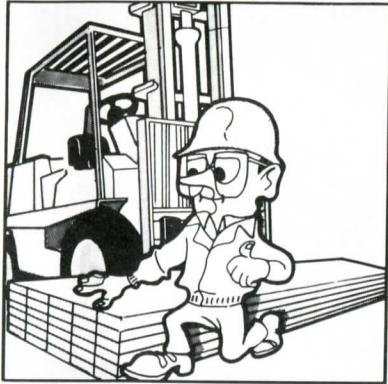

17803
17532

21. Thoroughly inspect all loads to be moved for overload and/or poor balance. If the stability of a load is questionable, don't move it.

22. Unstable loads are a hazard to you and to your fellow workers. Always make certain that your load is well stacked and evenly positioned across both forks. Never attempt to lift a load with only one fork.

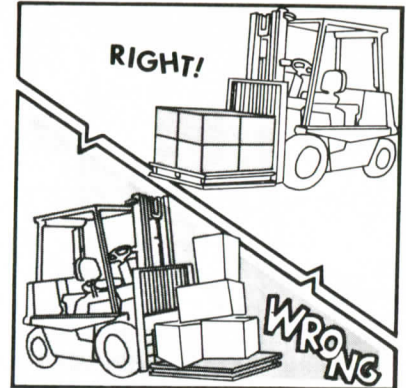

17804
17533



23. Before lifting check to insure adequate unobstructed overhead clearance. Gradually and smoothly pull back on lift control lever. Return lever to neutral to stop lift at desired level.

24. Push forward on control lever to lower load.

Descent of load may be stopped at desired level by returning lever to neutral position.

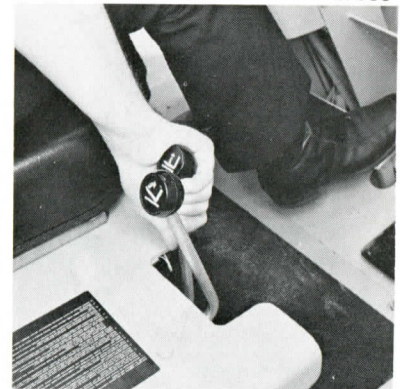

Safety

25. Always travel with load NEAR the operating surface and upright tilted back to cradle your load.

Never lift or lower the load while your truck is in motion and remember to keep your load up grade when operating on ramps or inclines. Never attempt to turn on ramps or inclines.

27. Remain seated at all times and keep head, hands, arms, feet and legs within the confines of the operator's compartment.

Never reach into the upright for any reason.

Never climb on the upright or use it as a ladder.

26. Never permit anyone to stand or walk under elevated forks or other load engaging attachments if machine is so equipped.

28. Fork lift trucks will overturn if improperly operated. Slow down for turns, ramps, bumps, cross aisles and wet or slippery surfaces.

Be particularly careful when operating in areas having soft and/or uneven surfaces.

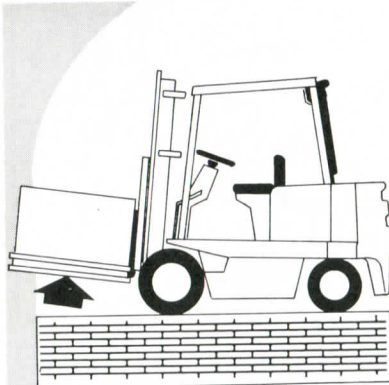

17805
17534

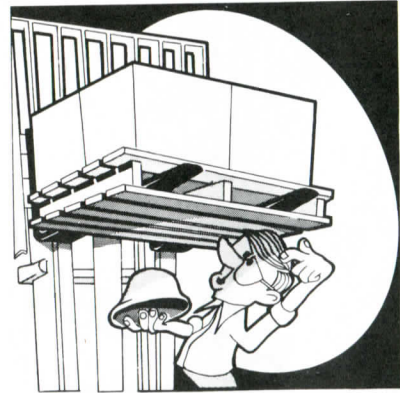

17635
13103

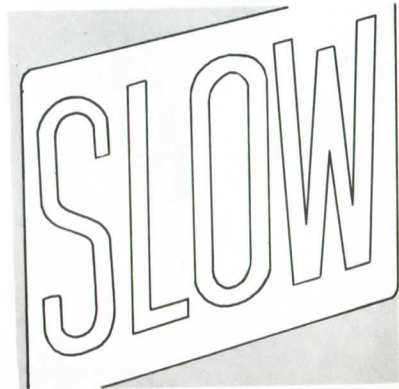

Safety



13102
17636



29. Know and observe floor load limits and overhead clearances in all operating areas. Make certain that floors of boxcars, trucks, trailers and elevators are adequate before entering.

31. Lift trucks must be refueled in designated areas only. Engines must be stopped and no smoking regulations strictly enforced.

Spilled fuel must be washed away or completely evaporated and the fuel tank cap properly replaced before restarting engine.

30. Use caution when placing loads or traveling near water pipes, overhead sprinklers, electrical wiring, steam pipes, heaters or other fragile or dangerous equipment or material.

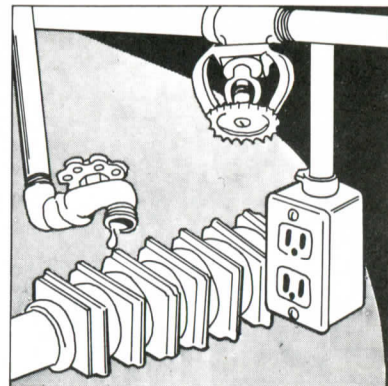

32. Never smoke or allow anyone to smoke in areas where batteries are being charged or in areas where fuels or other flammable fluids or materials are used or stored. Batteries must be charged in designated areas only and must be serviced only by thoroughly trained and qualified personnel.

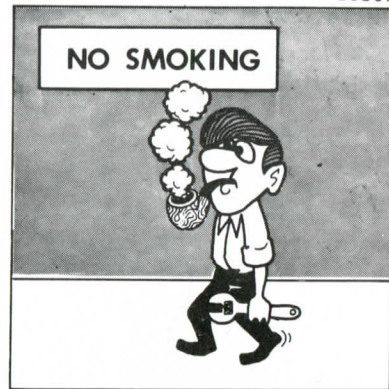

Safety



17637
17529

33. Park lift trucks in designated areas only. Lower forks to floor, tilt upright forward, place directional control in neutral, apply parking brake, remove switch key and block drive wheels to prevent accidental roll.

34. If truck is to be left unattended make certain that traffic aisles are unobstructed and leave truck as described in item 33.

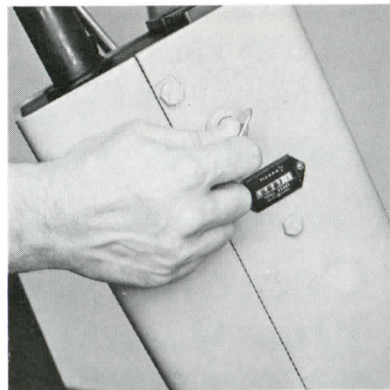

17535
17638



35. When handling bulky loads which, because of their size and shape, restrict your vision — operate your truck in reverse to improve visibility.

36. Overhead guards and load backrest extensions are for your protection. Make certain they are securely mounted and undamaged before operating your truck.

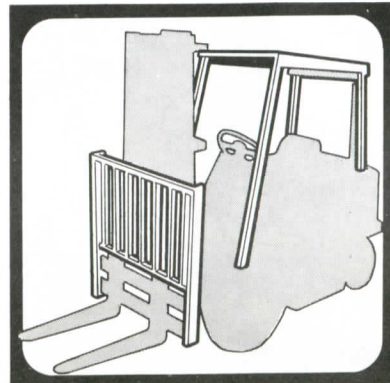

Safety

37. Do not use your lift truck to lift personnel.



17631
17633

38. Don't handle double tiered loads. They're unstable and difficult to control. Even an overhead guard can't fully protect you from heavy objects dropped from these heights.

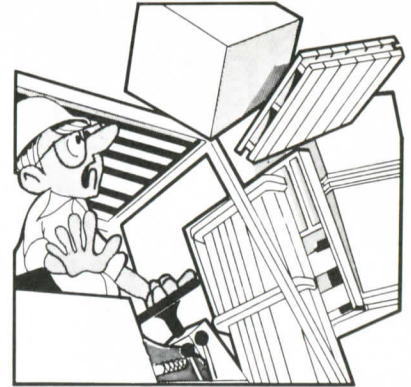

17632
17634

39. Overloading is extremely dangerous. You don't have complete control of your truck and you are causing unnecessary wear.

Never add to your counterweight, always break down the load.



40. Don't pass other trucks traveling in the same direction at intersections, blind spots or other dangerous locations.

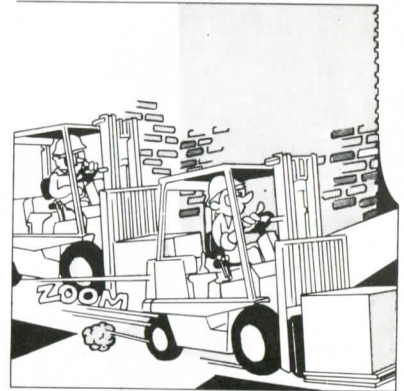

Safety



17627
17628

41. Check gauges, horn, upright and controls before you start. Inspect fuel, oil and water levels. Take pride in operating a good, clean truck.

42. Report any faulty truck performance to your supervisor immediately. Don't try to make repairs yourself.



16782
17629

43. Use of truck on public roads shall conform to local regulations. Cross railroad tracks at an angle wherever possible. Do not park closer than eight feet from center of tracks.

44. Use minimum forward or reverse tilt when stacking and unstacking loads.

Never tilt forward unless load is over stack or at low lift height.

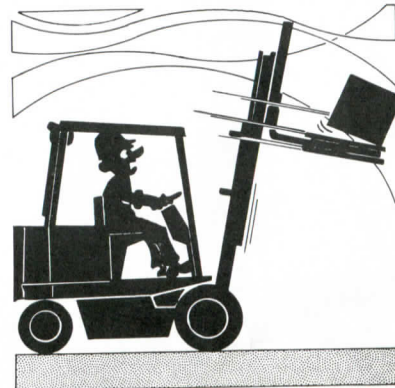
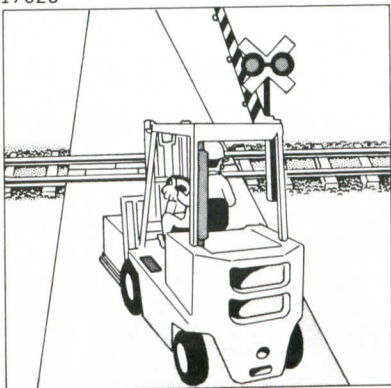

Safety

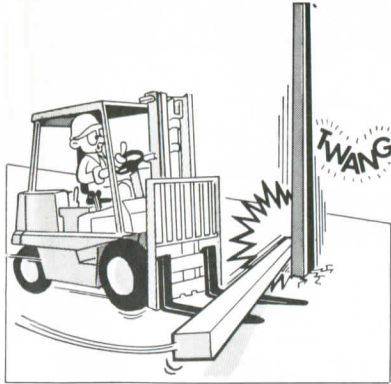

17630
13160

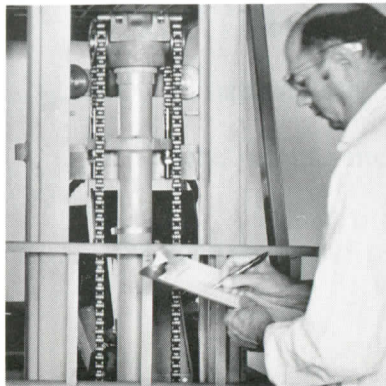

45. When extra length of material being handled makes it necessary to travel with your load elevated, do so with extreme care and be alert to load end swing when turning.

47. Follow a scheduled planned maintenance and lubrication program.

All adjustments and repairs must be performed by thoroughly trained and authorized personnel only.

46. Know the construction type of your truck and make certain that trucks of this type may be operated in restricted areas before entering. Never take an unauthorized truck into restricted or hazardous areas. (Refer to item 20 on page 8).

48. Remember — your safety and the safety of others depends on you.

Keep your mind on the safe operation of your truck at all times.

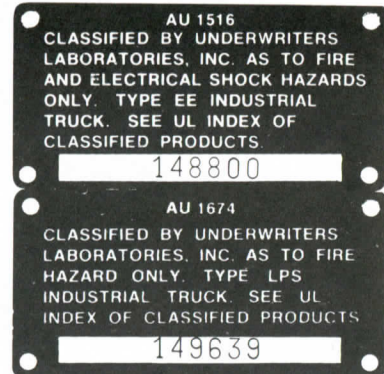

13178
17534



Operator's Compartment & Controls

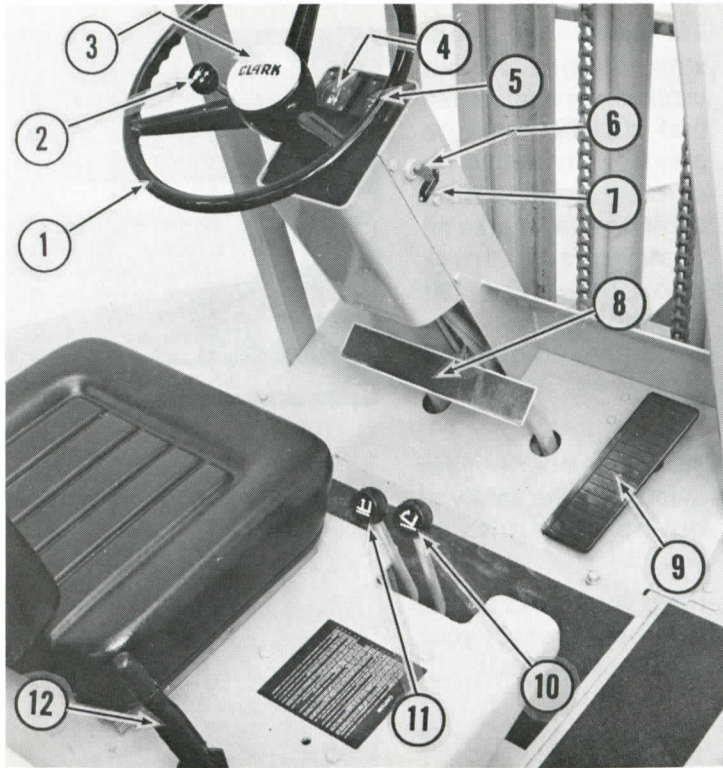

17536

C300Y40(D)
OPERATOR'S CONTROLS
Gas — Diesel — L.P. Gas

1. Steering Handwheel
 2. Transmission forward — Reverse Control Lever
 3. Horn Button
 4. Fuel Gauge (Gas & Diesel only)
 5. Instrument cluster (includes indicator lights for water temperature, ammeter and oil pressure in engine and transmission)
 6. Key Operated Ignition-start Switch
 7. Hour Meter
 8. Service Brake Pedal
 9. Accelerator Pedal
 10. Upright Tilt Control Lever
 11. Upright Lift-Lower Control Lever
 12. Parking Brake Control Lever
- Transmission High-Low Range Shift Lever (see page 30)
 - Diesel Engine Stop Control Handle (see page 32)
 - Gas and L.P. Gas Engine Choke Control (see page 23)
 - Diesel Cold Starting Aid Control (Located on Left Side of Steering Pylon (see page 39)

Before Operation



15197
17537



3. Check condition of drive wheels and tires.

Note any apparent drive wheel or tire damage on the check list.

Check drive tire pressure and adjust, if necessary, to pressures listed on page 34.

2. Walk around truck and visually check for damage and leaks.

Note all damage and leaks on check list.

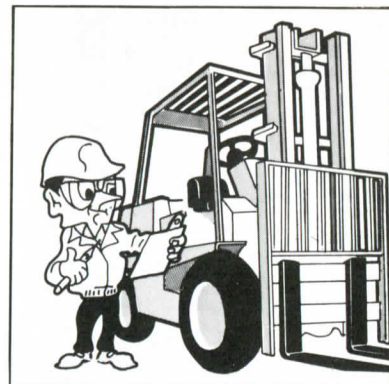

17814
17538



4. Check condition of steer wheels and tires.

Note any apparent steer wheel or tire damage on the check list.

Check steer tire pressure and adjust, if necessary, to pressures listed on page 34.

Before Operation

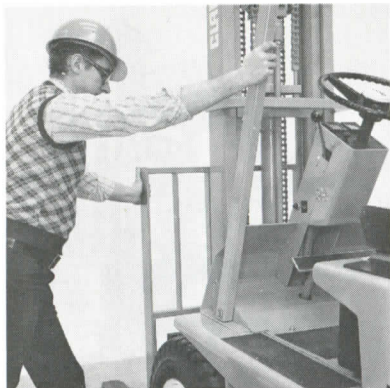

17539
17541

5. Check condition of overhead guard and load backrest extension.

Make certain that they are undamaged, properly positioned and mounted securely.



7. Remove fluid level plugs from all battery cells and check fluid level in each. Add distilled battery water as necessary. Replace all battery cell plugs.

Don't forget to return the flexible battery cover to its proper operating position.

6. Lift the flexible battery cover at the left side of the operator's seat. Visually note the condition of the battery, terminals and cables and mark your check list accordingly.

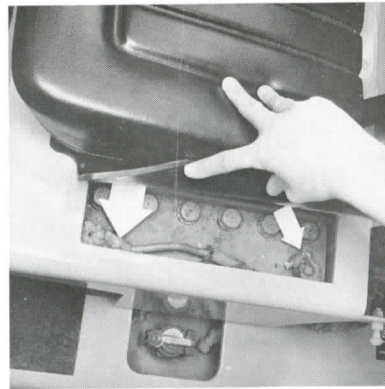

17540
17542

8. Unlatch the right hand side panel and pull it toward you to open it.

Swing the side panel toward the rear of the truck to completely expose the right side of the engine.

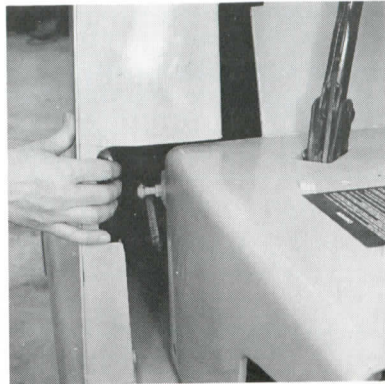

Before Operation

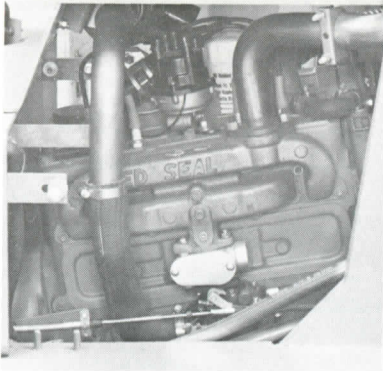

17569

9. Visually check the general condition of the engine compartment.

Note the condition of the fan, belts, hoses, fittings, wiring, etc.

Mark your check list to indicate your findings.

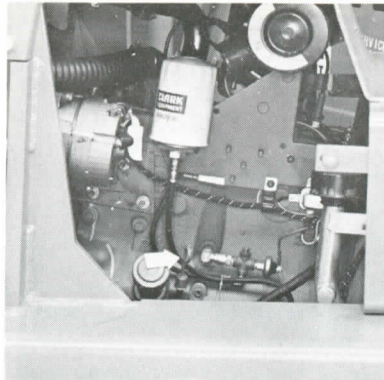

17568

10. The engine oil dipstick on gas and L.P. gas powered models is positioned as shown above . . .

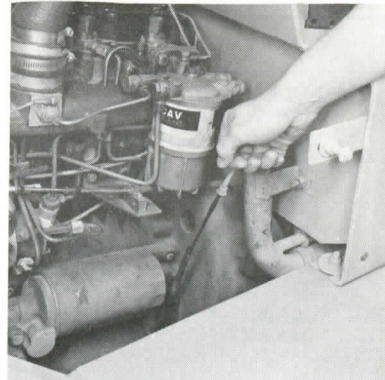

17543

11. ..On diesel powered models this is the location of the engine oil dipstick.

Pull the dipstick from its support tube, wipe it dry with a clean, lint-free cloth and reinsert it fully into its support tube.

Before Operation

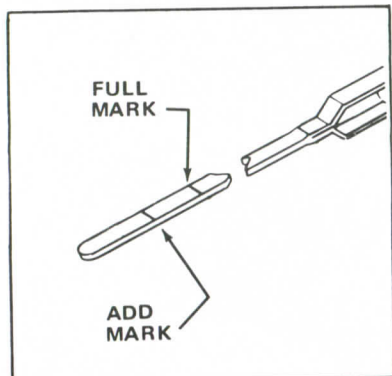

13239

12. Pull the dipstick from its support tube and check the engine oil level.

Oil level must be maintained between the "add" and "full" marks on the dipstick.

Remember that one quart (1 liter) of oil will raise the oil level from "add" to "full" — DO NOT OVERFILL.

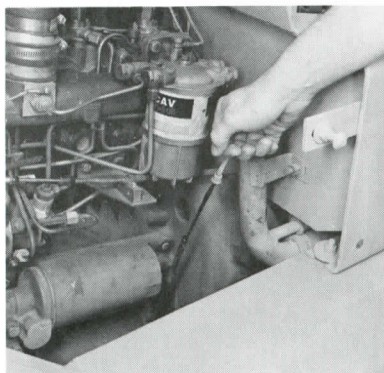

17543

13. Engine oil level should always be rechecked after oil has been added.

When engine oil level has been adjusted to the proper level — replace the dipstick making certain that it is inserted fully into its support tube.

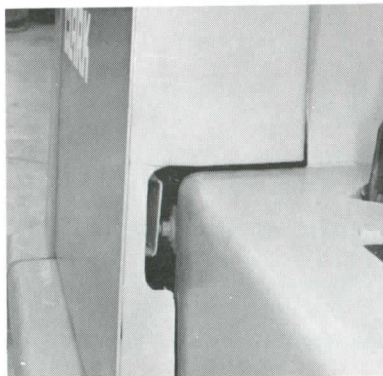

17544

14. Close the right hand side panel and check to make sure that it has latched in the closed position.

Before Operation

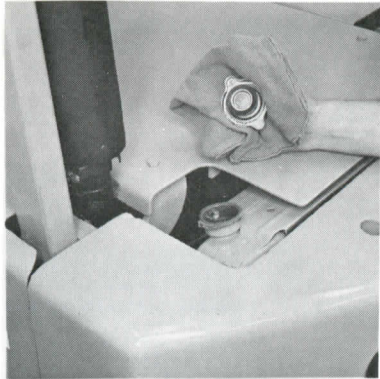

17545
13221

15. Always check radiator coolant level with engine turned off and cold, if possible. **Caution** — Use extreme care when removing radiator pressure cap. The sudden release of pressure can cause a steam flash resulting in serious injury. Place a rag over the radiator cap and loosen slowly to allow gradual escape of steam.

Never add cold water or cold anti-freeze into the radiator of an overheated engine. Allow the engine to cool and avoid the danger of cracking the cylinder head or block. Keep engine running while adding water or anti-freeze. A solution of 50% ethylene glycol and 50% water is recommended — never use water only.

Remember to replace radiator cap and make certain that it is properly secured after check of radiator coolant level has been completed.

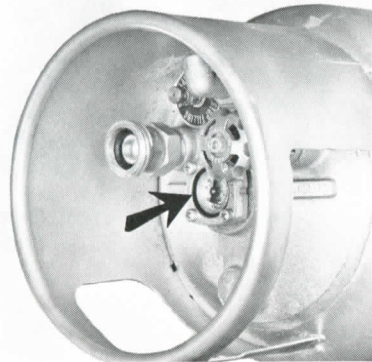

16. If your truck is L.P. gas powered you should now walk to the back of your truck and check the fuel level. The fuel gauge is located as indicated by the arrow at left.

Refer to page 38 of this manual for tank changing procedures.

17. After tank fuel level has been checked and adjusted (if necessary) slowly turn fuel shut-off valve counterclockwise.

If this valve is opened too quickly, an automatic check valve will close. When this occurs you must close the valve, wait several minutes and slowly re-open the valve.

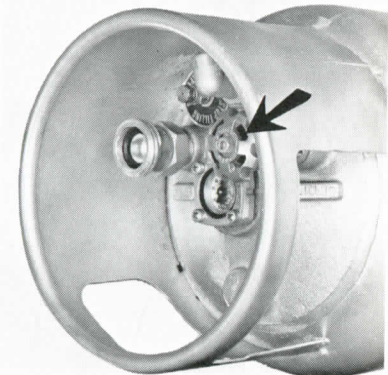

13245

Before Operation



17546
17548

18. Remove blocks from drive wheels, carefully enter operators compartment and seat yourself in the operators seat.

19. Seat adjustment is accomplished by releasing short lever at lower right front of seat.

Position seat to provide easy access to all hand and foot controls, free lever and make certain that seat locks into desired position.

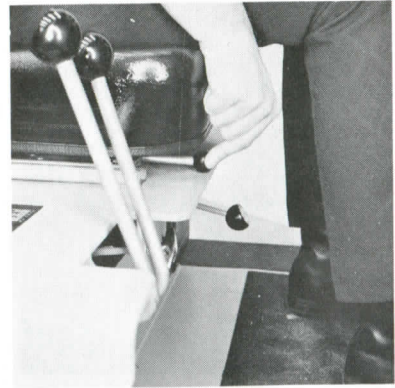

17547
17549



20. Place foot on service brake pedal and apply pressure by pushing down.

Pedal should be "firm." If pedal feels "spongy" or "fades" under pressure DO NOT OPERATE THE TRUCK. Report brake deficiency immediately to the proper authority.

21. Make certain the parking brake lever is in the "on" (full-up) position.

Brake holding power can be adjusted by rotating the knob on top of the lever clockwise to increase holding power or counterclockwise to reduce it. (See page 34 of this manual for holding specifications).



Before Operation

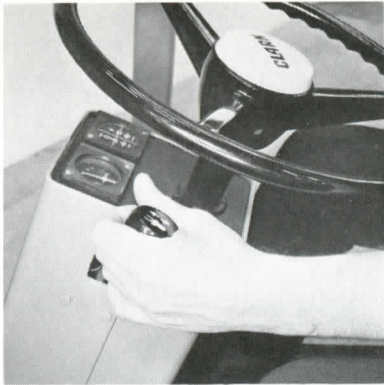

17550

22. Check to make sure that transmission directional control lever is in neutral position. These trucks are equipped with a neutral start switch and cannot be started in forward or reverse unless switch is faulty or improperly adjusted. Report switch condition on your check list.



17567

23. Gas and some L.P. gas trucks are equipped with a manual choke. This control must be pulled when starting a cold engine.

On L.P. gas models the choke (if so equipped) should be pushed in as soon as the engine starts. On gas models the choke should be pushed in gradually as the engine begins to warm up once started. (Refer to page 39 for cold start procedures on the diesel powered models).

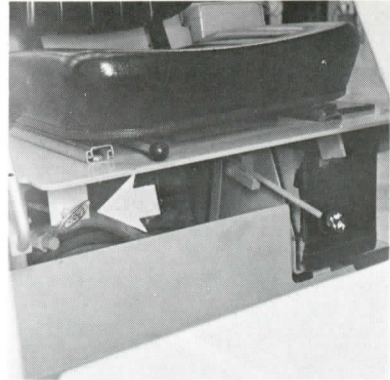

17551

24. If your truck is diesel powered you should check the engine stop control to make certain that it is pushed all the way in before you attempt to start the engine.

Before Operation

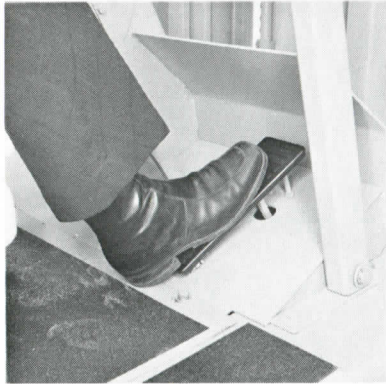

17552

25. Place your right foot on the accelerator pedal.

On gas and L.P. gas powered models only slight foot pressure will be required to start the engine.

On diesel powered models push accelerator pedal $\frac{1}{2}$ -to $\frac{3}{4}$ of travel to start engine.

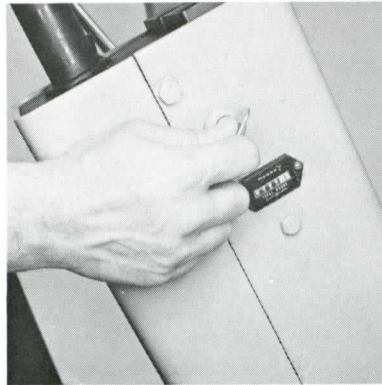

17535

26. Insert ignition switch key and turn clockwise to "start" position.

Release key to return to "run" position as soon as engine starts.

If engine does not start on the first attempt — do not re-engage the starter until the engine comes to a complete stop (approx. 5 sec) and remember that switch must be returned to the "off" position before starter can be re-engaged.

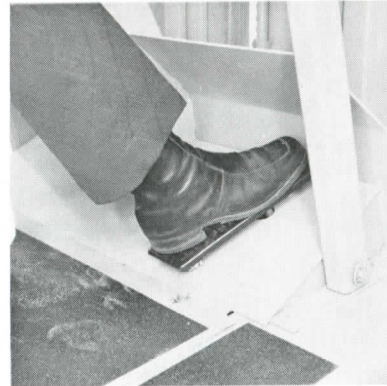

17553

27. If gas or L.P. gas engine becomes overchoked or "flooded" in starting, push choke control in — press accelerator pedal to floor board and engage the starter as described in item 26.

Before Operation

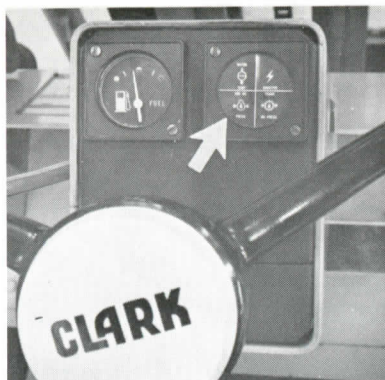

17554

28. These trucks are equipped with a dash mounted engine oil pressure indicator light. This light should go out shortly after the engine starts.

If this light does not go out, or if it comes on at any time during operation you should immediately shut down your engine and do not attempt to restart it until the cause has been located and corrected.



17555

29. These trucks are equipped with an electrical system charging indicator light (ammeter).

This light will go out shortly after the engine starts. If this light remains on, or if this light comes on during operation, you should immediately shut down your engine until the cause has been located and corrected.



17556

30. These truck models are all equipped with a water temperature indicator light. This light will go out shortly after the engine starts.

If this light remains on, or if it comes on at any time during operation, you should immediately shut down your engine and do not attempt to restart until the cause has been located and corrected.

Before Operation



17557

31. All of these truck models are equipped with a transmission oil pressure indicator light.

This light will go out shortly after the engine starts. If this light remains on, or if it comes on at any time during operation you should immediately shut down your engine until the cause can be located and corrected.



17558

32. On gas and diesel powered units always check the fuel gauge to determine the amount of fuel in the tank.

It is recommended that you always start your shift with a full fuel tank. This is especially important on diesel models as it is possible to severely damage the injection pump and nozzles when a diesel runs out of fuel.

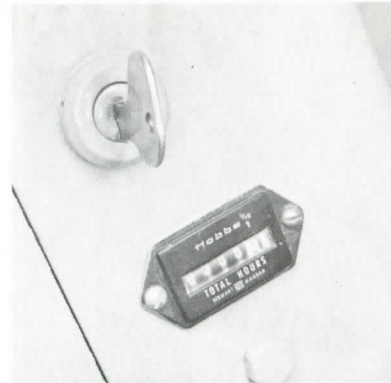

17559

33. The engine hour meter is located on the right side of the steering pylon below the switch key.

Make certain that it is undamaged and operating properly. Notice the total hours on the meter and record them on your Daily Check List.

Before Operation

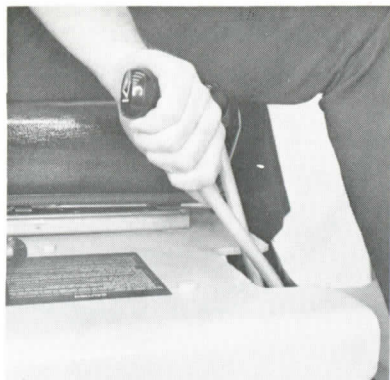

17560

34. Gently pull back on the tilt control lever and hold until upright reaches full back tilt.

Do not hold lever back after upright has reached full back tilt — to do so will unduly heat the hydraulic fluid and could harm the hydraulic system components.



17561

35. Push tilt lever forward and hold in position until upright tilts forward to near vertical position.

Return tilt lever to neutral position to halt forward tilting action at desired point.



17532

36. Carefully check for adequate unobstructed overhead clearance, then gently pull back on lift control lever and hold until upright reaches maximum lift height.

Return lift lever to its neutral position to halt lift at desired level.

Note any erratic upright operation on your check list.

Before Operation



17533

37. Gently push forward on lift control lever and closely observe descent of upright carriage.

Return lift control lever to its neutral position to stop upright descent near (about 4-6 inches) (100-150mm) floor level.

Record any erratic or unusual operation on your check list.

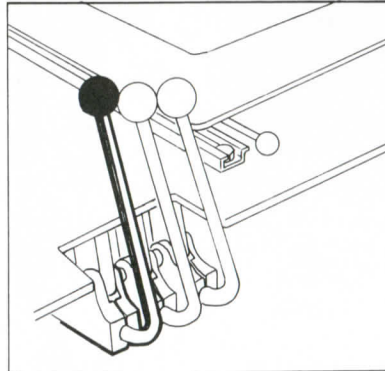

17815

38. Trucks equipped with hydraulic attachments or accessories will have one or more additional control levers mounted to the right of the lift and tilt control levers.

The function of these lever(s) should be checked with your supervisor prior to attempting operation thereof.



13141

39. Press horn button to determine if horn is operational.

If horn does not function properly record it on your check list and report it to the designated authority when you have completed your "before operation" checks.

Before Operation

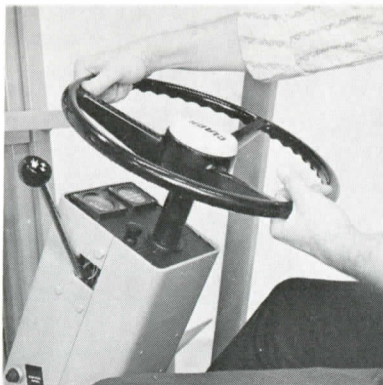

17562
17548

40. Rotate steering handwheel to the left and to the right.

Any excessive or unusual free travel, looseness or binding must be noted on your check list.

41. Check all around truck to make certain that your desired path of travel is unobstructed.



17529
17563



42. Place your right foot on the brake pedal and press down firmly to apply the truck service brakes.

43. Release the parking brake by pushing forward and outboard on the control lever.

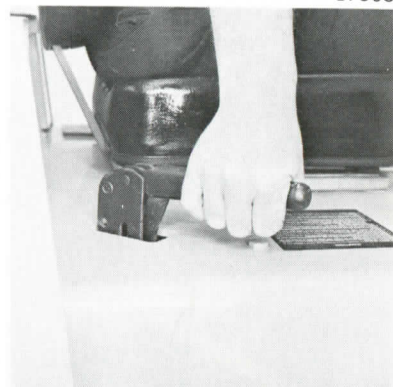

Before Operation

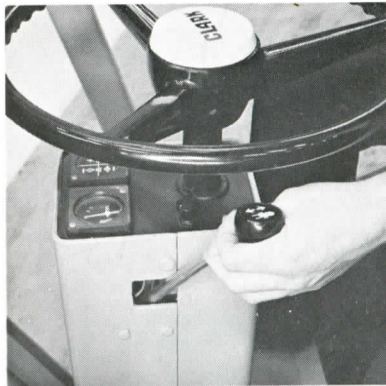

44. Place forward-reverse shift lever into proper position for desired direction of travel. (Pull lever back for reverse or push it forward for forward travel).

17564
17552



46. Release foot pressure on brake pedal. Place your right foot on the accelerator pedal and apply gentle downward foot pressure until the truck begins to move in the selected direction.

45. Place the transmission speed range selector lever in the "low" position (pull up for "low" — push down for high).

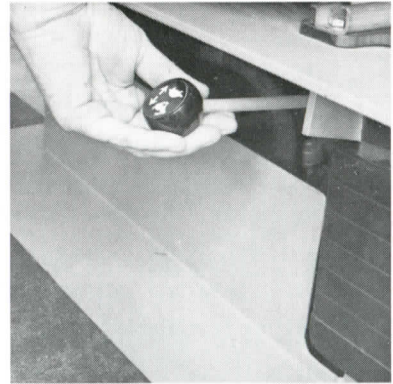

17565
17548

47. Release the accelerator pedal and place your right foot on the service brake pedal. Apply smooth downward foot pressure to the brake pedal until truck comes to complete stop.



Before Operation

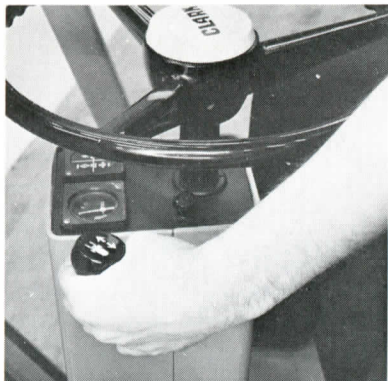

17566

17561

48. Move forward-reverse selector lever into position for direction opposite that selected in item 44 and repeat items 46 and 47.

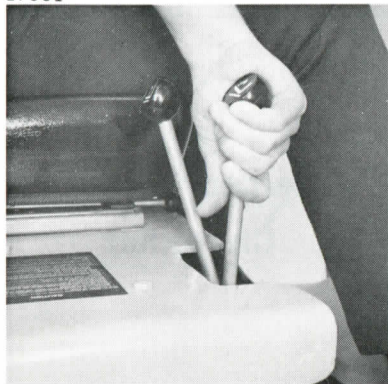

50. ...tilt the upright forward slightly to place fork tips on the floor.

49. Lower lift forks to floor and...

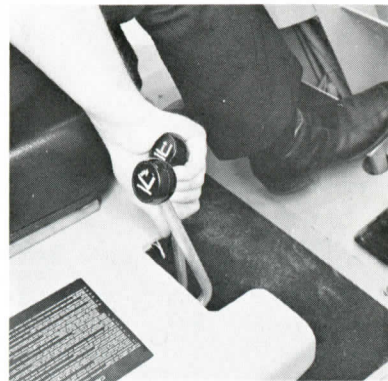

17533

17549

51. Place the forward reverse directional control lever in the neutral position, and firmly apply the truck parking brake by pulling the brake control lever toward you.



Before Operation

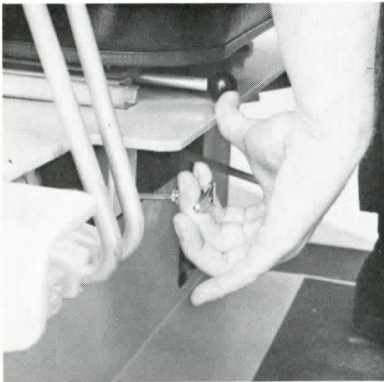

17570
17546

52. If your truck is diesel powered, pull out on the engine stop control and hold until the engine comes to a complete stop... then push the stop control in to the "run" position.

53. Turn switch key to the "off" position and remove the key from the switch.

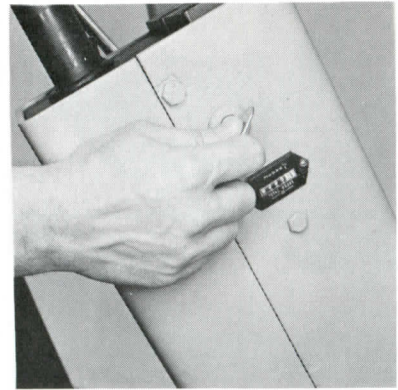

17535
15197



54. Carefully dismount from your truck and don't forget to securely block the drive wheels if the truck is to be left on a grade or incline.

55. Review your check list to make certain that it is complete, sign it and turn it in to the designated authority.



Operating Hints

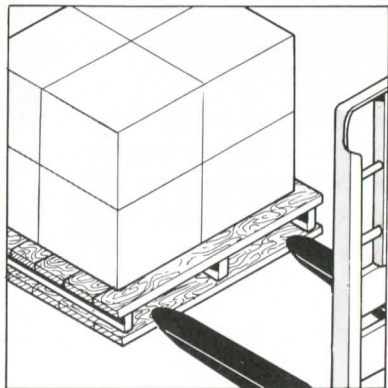

13203
10759

1. Remember to approach load slowly and squarely to avoid damaging the material being handled and to minimize truck maneuvering.

Load should be centered and forks should be near the outside edges to improve stability — if they are not...

3. ...Remember to lower lever to lock forks securely into notch atop fork bar.

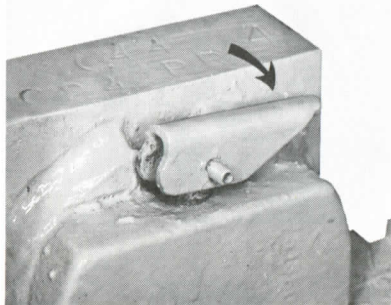

2. ...Adjust them by lifting fork lock lever and sliding forks to the desired position then...

4. Always be alert for abrupt changes in the operating characteristics of your truck.

Unusual noises or sudden changes should be reported to your supervisor immediately.



10758
17530



Operating Hints

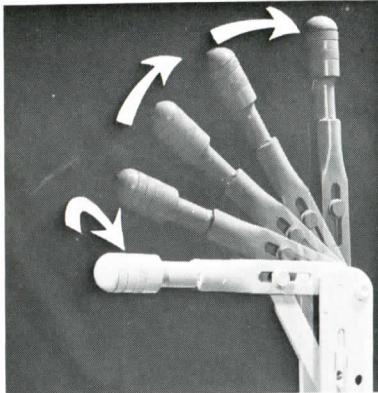

13228
17548



5. Parking brake performance is checked by moving lever from full "on" position to full "off" position. Maximum force will be required just before brake lever reaches full "on" position.

The parking brake should be adjusted to hold the truck, with capacity load, on a 15% grade (1.5 feet of rise in 10 feet or 45cm of rise in 3m) or on the maximum grade negotiated in your operation, whichever is less. Brake holding power can be adjusted by rotating the knob on the lever. Rotate it clockwise to increase tension or counterclockwise to decrease tension and holding power.

6. These trucks all have "inching" capability. The initial (approx. 1") brake pedal travel regulates oil pressure in the transmission. This allows controlled truck speed independent of engine speed which makes fast lifting possible while maintaining slow travel speed.

7. Always keep your tires inflated to the proper pressures.

Drive Tires

7.00 × 12-12ply
120 PSI(8.20kPa)

Steer Tires

6.00 × 9-10ply
100 PSI(7.00kPa)

17816

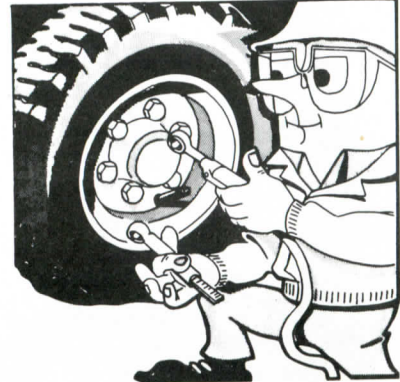

Operating Hints

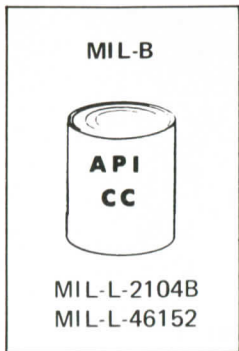

GAS — L.P.GAS ENGINE OIL SPECIFICATION To meet API Service Classification "CC" and "SC" per SAE Report J183 and/or MIL-L-2104B. Sulfated ash content 1.00% weight maximum. Zinc content 0.06 to 0.10% weight maximum.

This specification includes oils meeting Specification MIL-L-46152 when applicable. Also, API Service "SC"/"SD" (Formerly "MS") oils may be preferred under stop-and-go or light service conditions.

TYPICAL PRODUCT RECOMMENDED BY MAJOR BRAND OIL SUPPLIERS

Chevron RPM DELO Multi-Service Oil
Shell X-100 or Rotella, Rotella T
Sunfleet H.P. or Citgo C300 Motor Oil
ARCO Fleet X.H.D. Motor Oil or ARCO Fleet H.D.
Gulflube Motor Oil X.H.D.
AMOCO 200 Motor Oil
Texaco Havoline or URSA Extra Duty Motor Oil
Mobil Delvac 1100 B or 1200 Series Motor Oil
... or the equivalent to the above.

● ENGINE CRANKCASE OIL

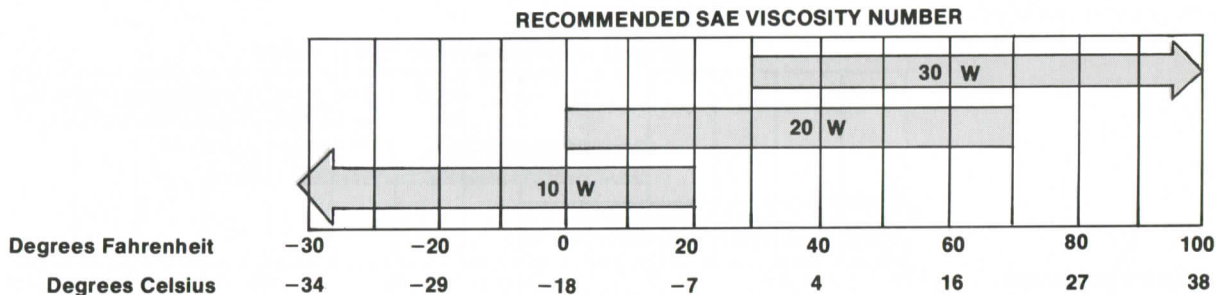

Operating Hints

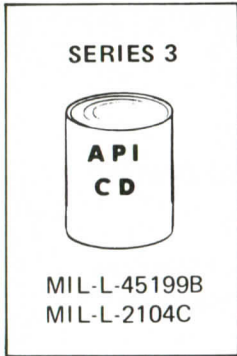

For... diesel engines using high sulfur content fuel (over 0.5% sulfur).

SPECIFICATION To meet API Service Classification "CD" per SAE Report J183 and equivalent Series 3 and/or MIL-L-45199B specifications. Also MIL-L-2104C when applicable. Sulfated ash content 1.65% maximum.

TYPICAL PRODUCT RECOMMENDED BY MAJOR BRAND OIL SUPPLIERS

- Chevron DELO Super 3 Oil
- Shell Rimula Motor Oil
- Sunfleet S-3 Motor Oil
- ARCO Fleet MS-3 Motor Oil
- Gulf Super Duty Motor Oil
- AMOCO 300 Motor Oil
- Citgo C500 Motor Oil
- Texaco URSA LA-3 Motor Oil
- Mobil Delvac 1300 Series Motor Oil
- ... or the equivalent to the above.

SAE #30 oil of MIL-L-2104B performance level is recommended for year around use in Detroit diesel engines... (Limitations — zinc. 0.10% maximum, sulfated ash 1.0% maximum.). The use of Multi-grade oils in Detroit diesel engines is not recommended.

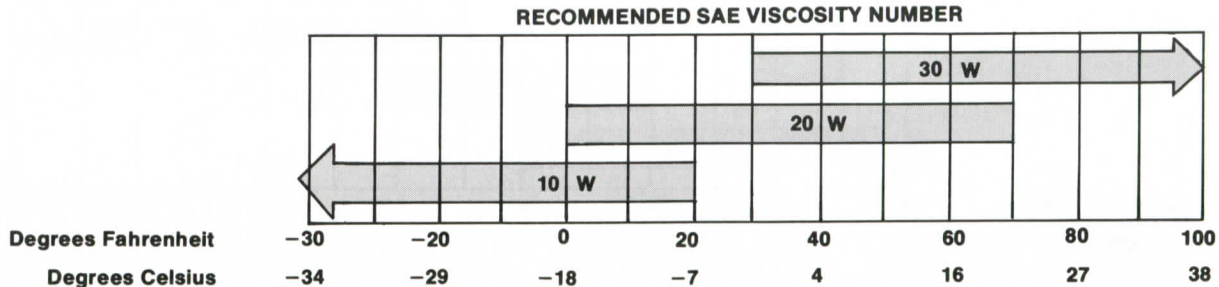

Operating Hints

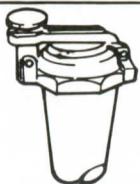

GASOLINE

GASOLINE

SPECIFICATIONS Fuel to be Automotive Quality Regular Grade Gasoline containing a corrosion inhibitor.

Minimum Motor Octane
Number — 85

TYPICAL PRODUCT RECOMMENDED BY

MAJOR BRAND OIL SUPPLIERS
Shell or Citgo Regular Gasoline
Sunoco 200 or Good Gulf Gasoline
American Regular Gasoline
Texaco Firechief Gasoline
ARCO or Mobil Regular Gasoline
... or the equivalent to the above.

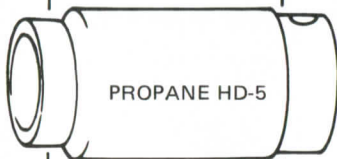

L. P. GAS

L.P. GAS

SPECIFICATIONS USE LPG meeting PROPANE HD-5 (NGPA Specification 2140-62) or ASTM D2154 (Special Duty Propane) requirements.

Minimum Motor Octane
Number — 95

Citgo L.P. Gas (HD-5)

Texaco 436 Propane
... or the equivalent to the above.



DIESEL

DIESEL

SPECIFICATIONS Fuel to be Automotive Quality Diesel Fuel Oil as defined by ASTM D975, Grades No. 1-D and 2-D, and having a sulfur content of less than 0.5% weight.

Recommended Cetane
Number — 45 Minimum

Shell Premium Dieseline O R45

Sun Diesel Fuel 245-T
ARCO Premium Diesel, Diesel #1 or #2
Gulf or Citgo Diesel Fuel #1 or #2
AMOCO Diesel Fuel #1D and American
Premier Diesel Fuel #2D
Texaco Diesel Chief #1
Mobil Fuel Diesel & Diesel Fuel Special
... or the equivalent to the above.

Operating Hints

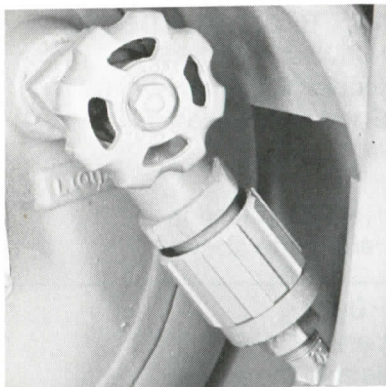

13250
13251

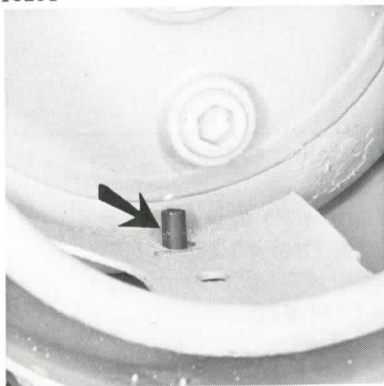

8. Whenever it becomes necessary to remove L.P. gas tanks to refuel you must:
 - a. Close the fuel shut-off valve at end of tank by turning it clockwise.
 - b. Operate engine until it stops. All gas vapors between tank and engine should then be burned off.
 - c. Turn ignition switch key counterclockwise to the "off" position.
 - d. Disconnect fuel line at quick-disconnect coupling. Tools should not be required to connect or to disconnect this coupling.
 - e. Loosen container fasteners and swing container mounting cover up and toward seat back.
 - f. Lift out empty container.

9. When reinstalling recharged L.P. gas tanks you must:
 - a. Carefully place recharged container in the mounting bracket.
 - b. Make certain that tank locating hole is positioned securely over the tank positioning pin in the bracket.
 - c. Swing container mounting cover into position over the new container and secure fasteners.
 - d. Reconnect fuel line to tank at quick disconnect coupling.
 - e. Open fuel valve as described in item 17 on page 21.

Operating Hints

1. Make sure engine "stop" control is in "run" position (pushed in).
2. Place transmission forward and reverse control levers in neutral.
3. Turn key-start switch to "start" position and hold for 15 seconds or until engine starts.
4. If engine does not start, turn key to "off" position and wait for engine to come to complete rest (about 5 seconds).
5. If engine does not start after three tries, air in the fuel system may be the cause. Refer to designated authority and consult P.M. Manual.
6. The Perkins Diesel has a cold starting aid, consisting of a manifold heater. If the weather is cold, depress the "heat-start" button for 15 seconds with the key in "run" position. Now crank engine by turning key to "start."

If engine does not start, repeat procedure holding "heat-start" button in for 10 seconds.

At temperatures below 0°F.(-18°C), depress button for an additional 10 seconds while engine is running.

If engine fails to start, refer to Step 5.

CAUTION: Do not attempt to start engine with fuel tank empty.

17571

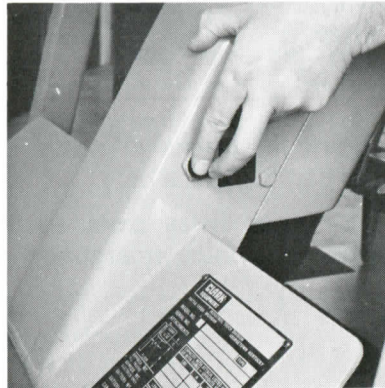

Operating Hints

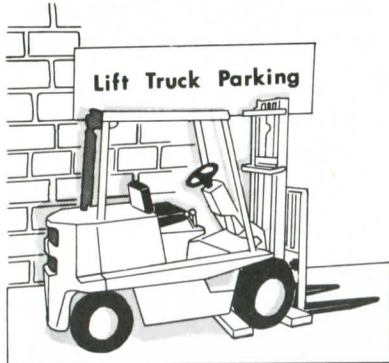

17637

1. Park lift trucks in designated parking areas only.

Do not block aisles, exits, entrances or other emergency lanes.

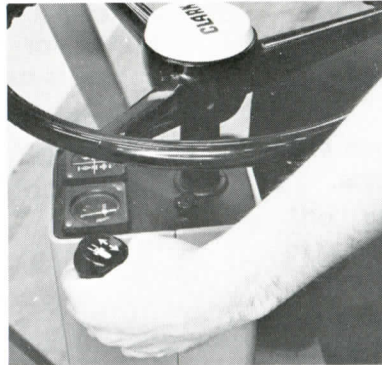

17566

2. Make certain that the transmission forward-reverse directional control lever is in the neutral position and...

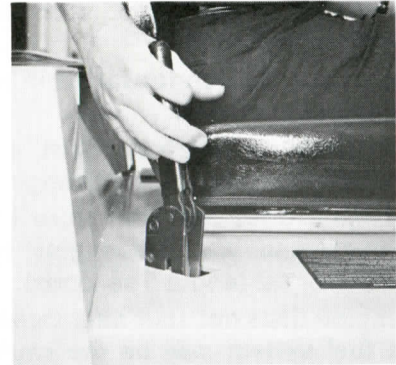

17549

3. ...that the parking brake is applied.

Operating Hints

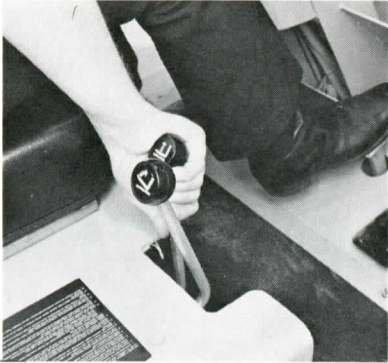

17533

4. Push forward on lift-lower control lever to lower upright load forks to floor level.

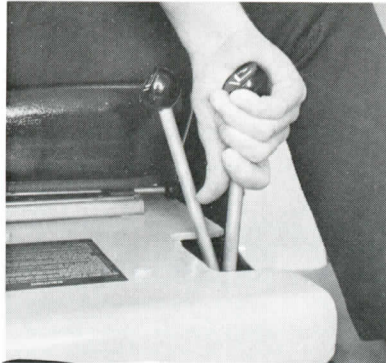

17561

5. Push forward on upright tilt control lever to position load fork tips nearer the floor.

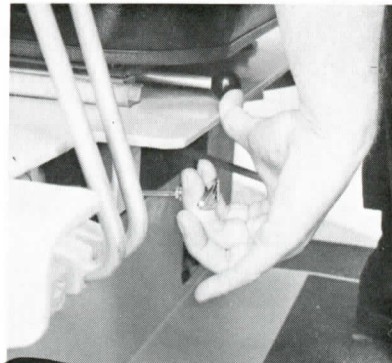

17570

6. If your truck is diesel powered it will be necessary to pull the engine stop control and hold it until the engine stops completely. When the engine has stopped move on to step 7.

Parking

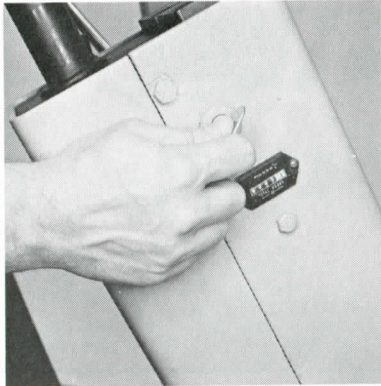

17535

7. If your truck is Gas or Diesel powered, you should now turn the switch key counterclockwise to the "off" position and remove the key. (If your truck is L.P. gas powered you should accomplish steps 8 and 9 before performing this step.)



17546

8. Carefully dismount from your truck.

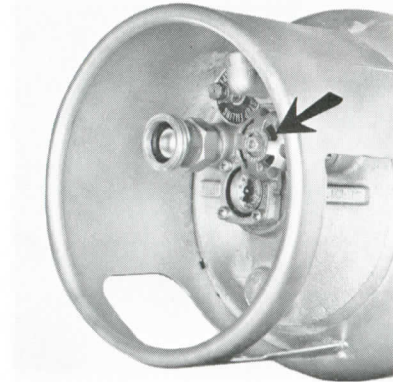

13245

9. If your truck is L.P. Gas powered you should now walk to the back of your truck, turn the manual fuel shut-off valve clockwise to the "off" position and wait for the engine to stop before performing step 7.

For Handy Reference

RECORD THE FOLLOWING INFORMATION PERTAINING TO YOUR TRUCK

Model _____

Serial No. _____

Attachments _____

Truck Weight (Empty) _____

Truck Rated Capacity _____

Gross Truck Weight (With Rated Load) _____

Transmission Type _____

Fuel Type (Gas, L.P. Gas or Diesel) _____

Tires (Pneumatic, Cushion) _____

Type Controls (Console or Column Mounted) _____

Customer Truck Identification _____

CLARK EQUIPMENT COMPANY
INDUSTRIAL TRUCK DIVISION
CUSTOMER SERVICES GROUP
BATTLE CREEK, MICHIGAN 49016

Additional copies of this manual may be purchased from:

**YOUR AUTHORIZED CLARK
DEALER**