

CLARK

Industrial Truck Division

OPERATOR

INSTRUCTIONS



IT60(D), IT70(D) & IT80(D) Gas or Diesel Powered

BOOK NO. OI-387 Rev. 1

6000 LBS., 7000 LBS. OR 8000 LBS.
RATED CAPACITIES

TABLE OF CONTENTS

Foreword	Page 1
Major Component Identification	Page 2 & 3
Safe Operating Rules and Practices	Page 4-15
Operator's Compartment and Controls	Page 16
Operator's "Before Operation" Checks	Page 17-32
Operating Hints	Page 33-39
Fuel and Engine Oil Recommendations	Page 36-38
Cold Weather Starts	Page 39
Parking Procedures	Page 40-42
Handy Reference Data	Page 45

FOREWORD

A large share of the total cost of most every product can be traced to handling. This includes in-plant transport, storage, freight, warehousing and final delivery. In many cases, the fork lift truck plays a key role in each of these operations.

You and your lift truck can significantly reduce these costs. . . . or increase them. A lift truck costs thousands of dollars. Add to this the cost of operation (operator's pay, fuel, maintenance, fringe benefits, etc.) and it can easily be seen that this is an important investment for any company. The investment has now been made and it is up to you to ensure that maximum return is realized.

This manual will help the "Qualified Operator" become familiar with the lift truck's major components, its operating controls, special features and the function(s) of each.

This publication is not a training manual but rather, a guide to help the "Qualified Operator" to more safe and efficient operation of a Clark lift truck.

Operator training manuals are available through your Clark dealer.

Clark trucks are built to take hard work not abuse — they are built to be dependable, but — as with any other truck — they are only as good as the man behind the wheel and the men responsible for maintaining them.

This manual guides the operator through correct procedures for checking, starting, operating, stopping and parking the lift truck.

Read it, Study it, Keep it handy.

Know Your Truck

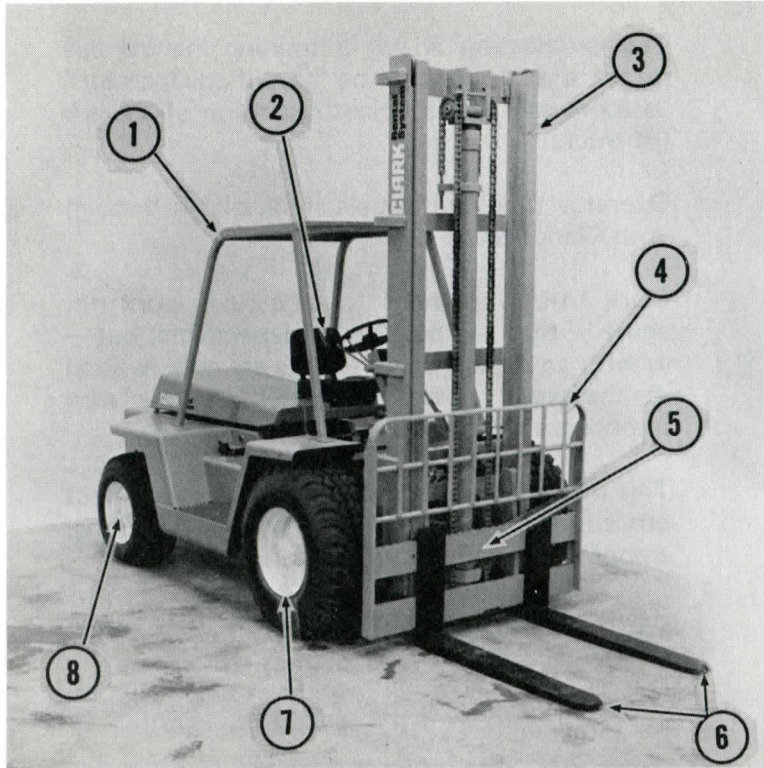

1. Overhead Guard
2. Operator's Compartment
3. Upright Assembly
4. Load Backrest Extension
5. Lift Carriage
6. Load Forks
7. Drive Wheel and Tire
8. Steer Wheel and Tire

17461

IT60, 70, 80
Gas Powered
6000 lbs. thru 8000 lbs. Rated Capacity

Know Your Truck

1. Overhead Guard
2. Operators Compartment
3. Upright Assembly
4. Load Backrest Extension
5. Lift Carriage
6. Load Forks
7. Drive Wheel and Tire
8. Fuel Filler Cap
9. Steer Wheel and Tire

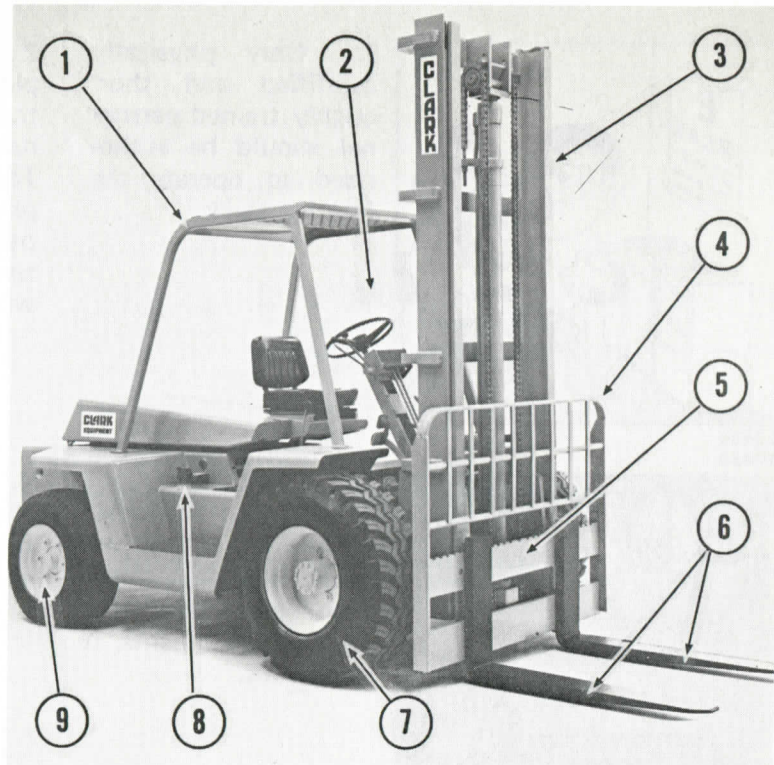

IT60D, 70D, 80D
Diesel Powered
6000 lbs. thru 8000 lbs. Rated Capacity

17820

Safety



17463
17464



Code: OI-387 Dec 75

5. Never operate a lift truck with wet or greasy hands or shoes.

6. Before operating any lift truck, test the horn, service brakes, hand brake, steering, lift-tilt controls, directional controls and any special devices for proper operation. Report any improper operation to the proper authority.

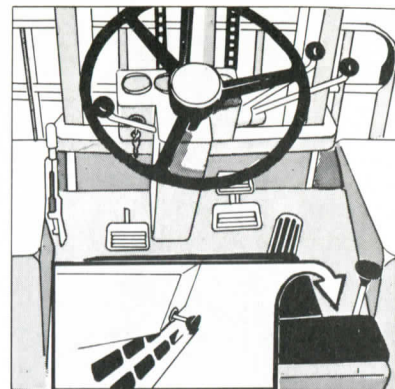

17614
17615

7. Always look all around the truck before moving it in any direction. Then remember to start and stop slowly and smoothly.

8. Operate the truck only in designated truck routes and keep operating aisles clear. One-way traffic is recommended. If this is not practical in your operation heed highway regulations and drive to right of aisle centerline.

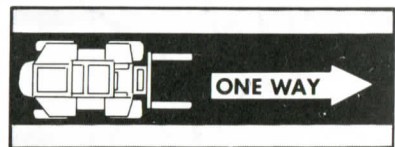
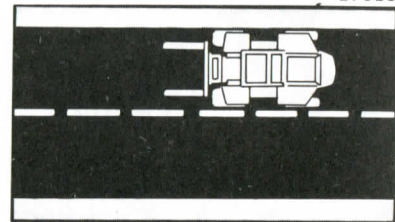

Safety



17465
13087



9. Be alert for pedestrians, other trucks or obstacles in your path of travel.

11. Obey all posted traffic rules and warning signs.

10. Sound horn at all corners, exits, entrances and when approaching pedestrians or bystanders.

12. Maintain a safe distance from the truck ahead of you at all times.

Assure ample distance to stop smoothly and safely should the need arise.

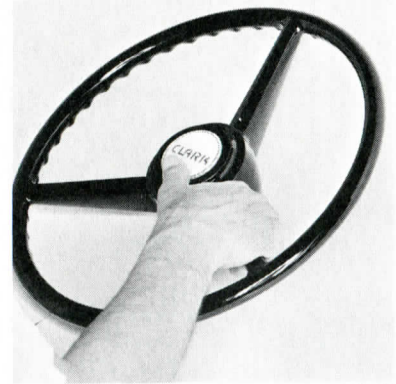

13141
17616

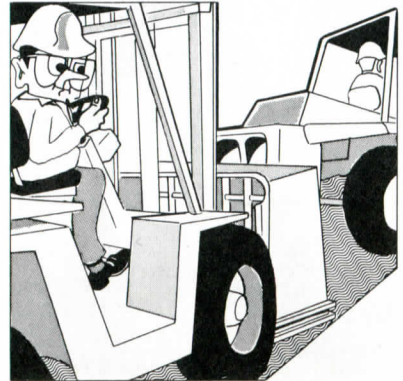

Safety

13. Be aware of rear end swing and be alert to prevent rear end swing damage to material in your operating area.

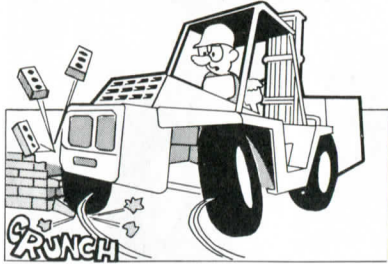

17578
17579



15. Be extremely cautious when operating truck near edge of loading dock, embankment, ditch or ramp.

14. Be aware of the position of your fork tips when the truck is in motion. Be alert to prevent striking anything with fork tips.

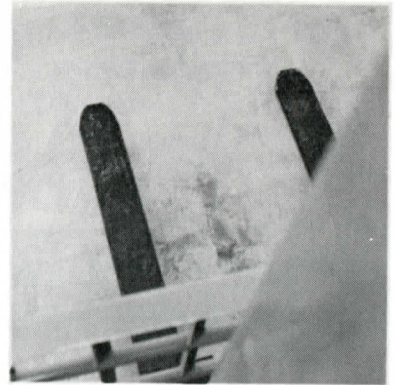

17466
17580

16. Make certain that vehicle being entered, loaded or unloaded has been blocked to prevent accidental roll.

Bridge plates, if used, must have adequate strength, width, guard rails, each side (minimum 3" high recommended) and be properly secured.

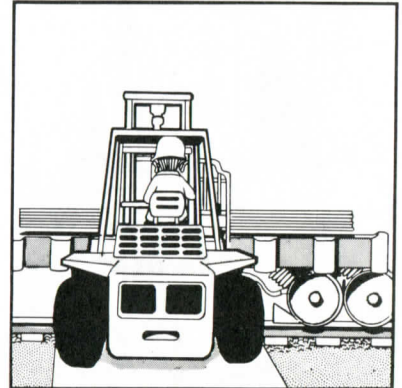

Safety

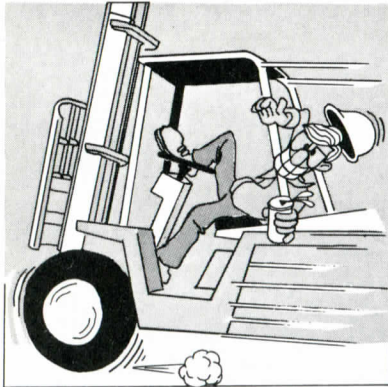

17581
17575

17. Never allow stunt riding or indulge in horseplay while operating a fork lift truck.

18. Never use your truck to push or tow another. Never allow your truck to be pushed by another.

This model truck should never be towed unless it has been optionally equipped with Clark approved two bar assembly. See your PMA manual for towing instructions.

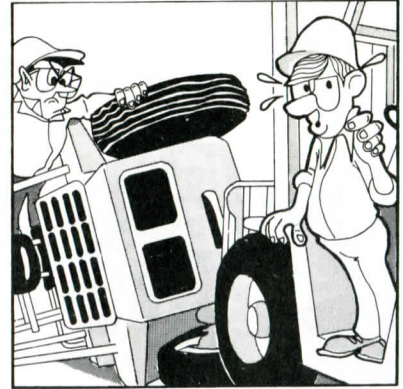

17574
13095



19. Never carry unauthorized passengers. The quick response of a lift truck may cause riders to fall off. Besides, they distract you and this is dangerous.

20. Know the capacity of your truck and its attachment (if any) and never exceed it. Study your truck data capacity plate and learn the facts stamped in areas 1 through 8.

Pay particular attention to area 3 and refer to item 46 on page 15 "Capacities are rated with mast vertical". See item 44 on page 14.

CLARK EQUIPMENT		1	
INDUSTRIAL TRUCK DIVISION BATTLE CREEK, MICHIGAN		TYPE 3	
MODEL NO. _____		2	
SERIAL NO. _____		4	
ATTACHMENTS		CAPACITY WITH ATTACH LISTED ABOVE OR WITH FORKS UPRIGHTS VERTICAL	
		LBS. A B C	
5		6	
APPROX. WT. ALL TRUCKS		LESS BATT. *ELECTRICS	
APPROX. WT. ELECTRICS ONLY		WITH MAX. BATT. WT.	
BATTERY WT.		MAX. 7 MIN.	
CAPACITY		A.H. NO. VOLTS 8	
<small>FOR OTHER CAPACITIES CONSULT MANUFACTURER AS RELEASED FROM FACTORY THIS TRUCK MEETS THE DESIGN SPECIFICATIONS ESTABLISHED IN AMERICAN NATIONAL STANDARD FOR POWERED INDUSTRIAL TRUCKS. PART II, ANSI B 56 1-1969 PT. NO. 2315709</small>			

Safety



17576
17467

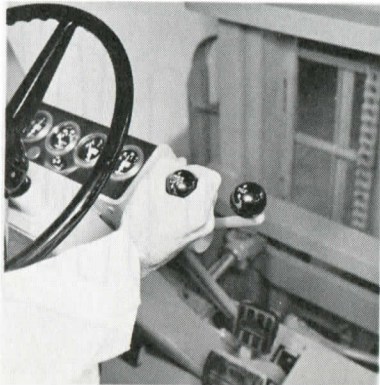

21. Thoroughly inspect all loads to be moved for overload and/or poor balance. If the stability of a load is questionable, don't move it.

22. Unstable loads are a hazard to you and to your fellow workers. Always make certain that your load is well stacked and evenly positioned across both forks. Never attempt to lift a load with only one fork.



17577
17468

23. Before lifting check to insure adequate unobstructed overhead clearance. Gradually and smoothly pull back on lift control lever. Return lever to neutral to stop lift at desired level.

24. Push forward on control lever to lower load. Descent of load may be stopped at desired level by returning lever to neutral position.

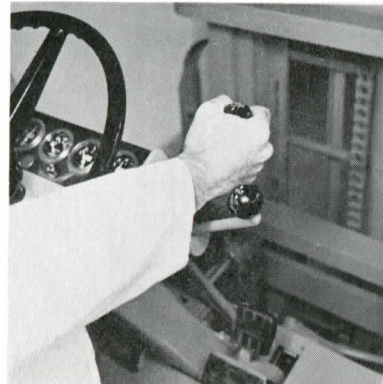

Safety



17621
17465



25. Always travel with load NEAR the operating surface and upright tilted back to cradle your load.

Never lift or lower the load while your truck is in motion and remember to keep your load upgrade when operating on ramps or inclines.

27. Remain seated at all times and keep head, hands, arms, feet and legs within the confines of the operator's compartment.

Never reach into the upright for any reason. Never climb on the upright or use it as a ladder.

26. Never permit anyone to stand or walk under elevated forks or other load engaging attachments if machine is so equipped.

28. Slow down for turns, ramps, bumps, cross aisles, wet or slippery floors and at all times when visibility is restricted.

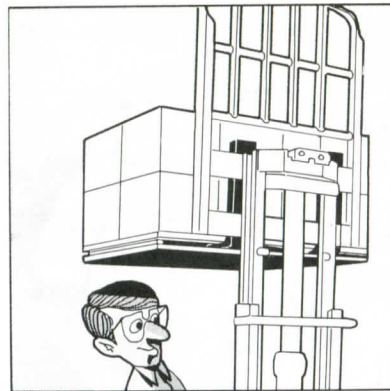

13522
13103

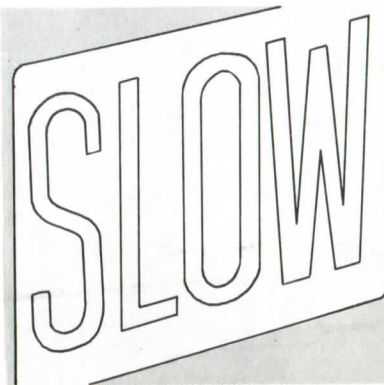

Safety



13102
17622

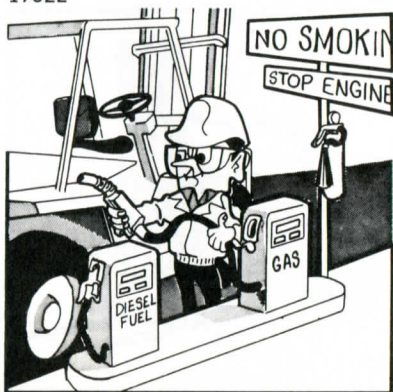

Code: OI-387 Dec 75

29. Know and observe floor load limits and overhead clearances in all operating areas. Make certain that floors of boxcars, trucks, trailers and elevators are adequate before entering.

30. Use caution when placing loads or traveling near water pipes, overhead sprinklers, electrical wiring, steam pipes, heaters or other fragile or dangerous equipment or material.

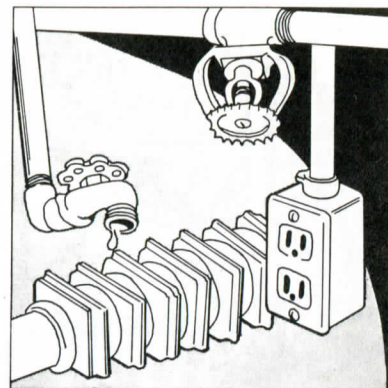

13104
13107

31. Lift trucks must be refueled in designated areas only. Engines must be stopped and no smoking regulations strictly enforced. Spilled fuel must be washed away or completely evaporated and the fuel tank cap properly replaced before restarting the engine.

32. Never smoke or allow anyone to smoke in areas where batteries are being charged or in areas where fuels or other flammable fluids or materials are used or stored. Batteries must be charged in designated areas only and must be serviced only by thoroughly trained and qualified personnel.

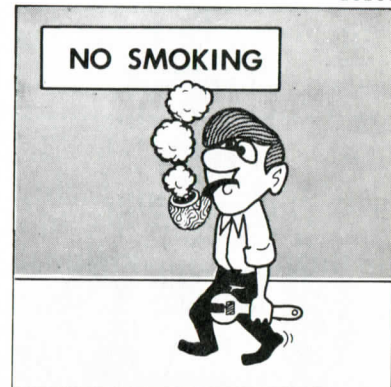

Safety



16777
17583

37. Lift trucks are not designed as personnel elevators. If your truck must be used this way always use a properly designed safety platform securely attached to the forks.

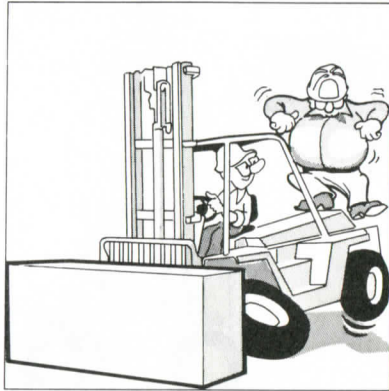

39. Overloading is extremely dangerous. You don't have complete control of your truck and you are causing unnecessary wear.

Never add to your counterweight, always break down the load.

38. Don't handle double tiered loads. They're unstable and difficult to control. Even an overhead guard can't fully protect you from heavy objects dropped from these heights.

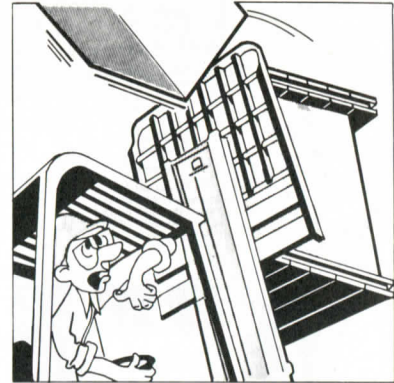

17582
17584

40. Don't pass other trucks traveling in the same direction at intersections, blind spots or other dangerous locations.

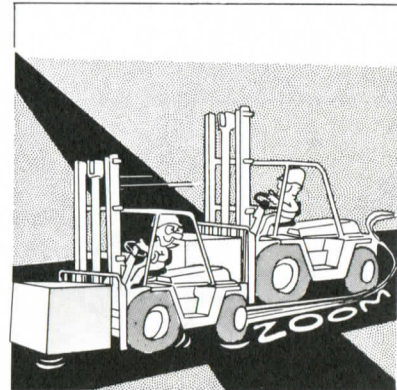

Safety

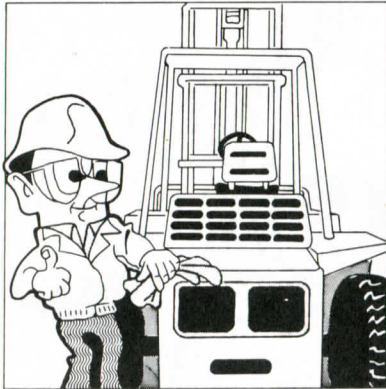

17585
17617

41. Check gauges, horn, upright and controls before you start. Inspect fuel, oil and water levels. Take pride in operating a good, clean truck.

42. Report any faulty truck performance to your supervisor immediately. Don't try to make repairs yourself.



16782
17618

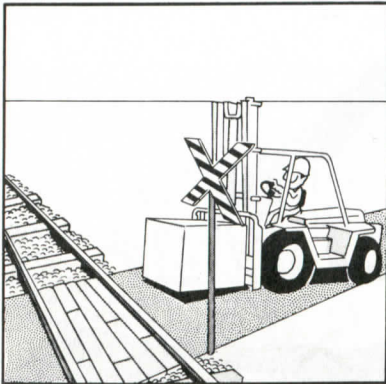

43. Use of truck on public roads shall conform to local regulations. Cross railroad tracks at an angle whenever possible. Do not park closer than eight feet from center of tracks.

44. Use minimum forward or reverse tilt when stacking and unstacking loads. Never tilt forward unless load is over stack or at low lift height.



Safety



17619
13160

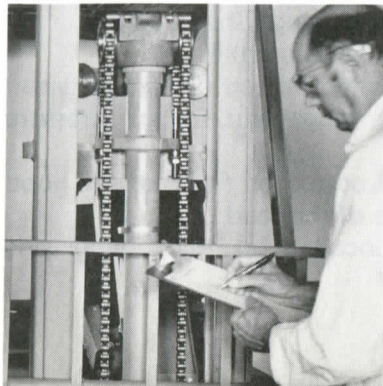

45. When extra length of material being handled makes it necessary to travel with your load elevated, do so with extreme care and be alert to load end swing when turning.

46. Know the construction type of your truck and make certain that trucks of this type may be operated in restricted areas before entering. Never take an unauthorized truck into restricted or hazardous areas. (Refer to item 20 on page 8.)

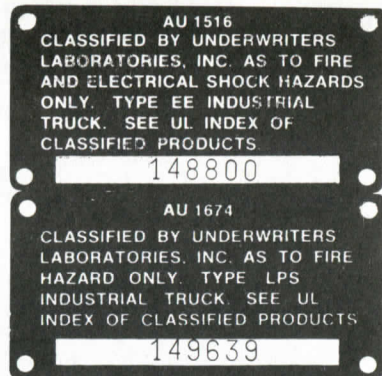

13178
17465

47. Follow a scheduled planned maintenance and lubrication program. All adjustments and repairs must be performed by thoroughly trained and authorized personnel only.

48. Remember — your safety and the safety of others depends on you. Keep your mind on the safe operation of your truck at all times.



Operator's Compartment & Controls

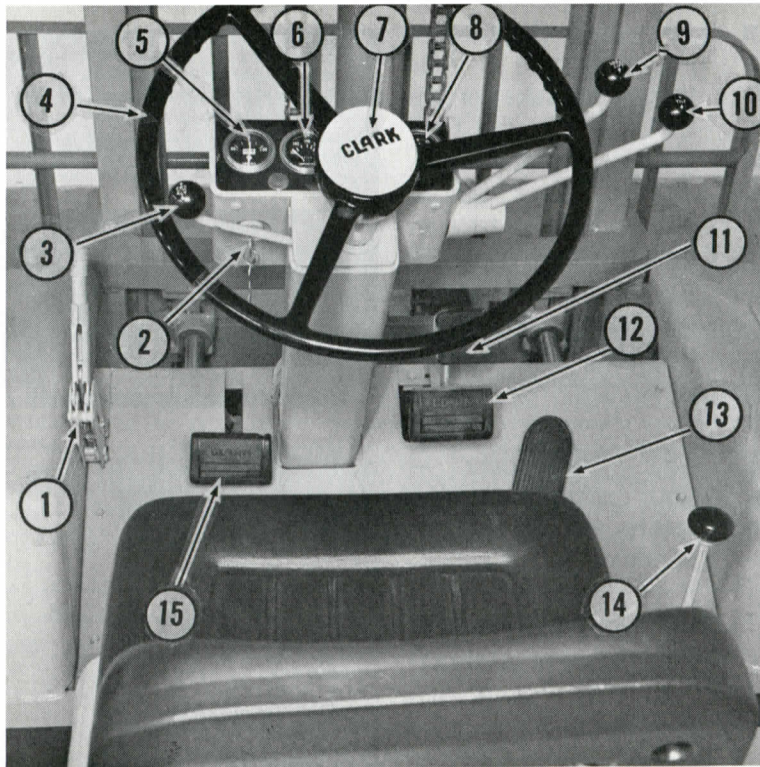

17470

**IT60, 70, 80 (Gas and Diesel Powered)
Operator's Controls**

1. Parking Brake Lever
2. Ignition Switch
3. Forward – Reverse Control Lever
4. Steering Hand Wheel
5. Ammeter
6. Temperature Gauge
7. Horn Button
8. Engine Oil Pressure Gauge
9. Upright Lift-Lower Control Lever
10. Upright Tilt Control Lever
11. Aux. Accelerator Pedal
12. Service Brake Pedal
13. Accelerator Pedal
14. Transmission Speed Range Shift Lever
15. Transmission Dump (Clutch) Pedal
16. Fuel Gauge (Located on top of dash between the temperature gauge and the oil pressure gauge).
17. Choke control (Located on front of the hood at right hand side of the seat).
18. Hour meter (Located on right hand side panel).

Before Operation



1. Each shift operator must complete an operator's daily check list at the beginning of his shift.

These daily check lists are available from your Clark dealer.

2. Walk around truck and visually check for damage and leaks.

Note all damage and leaks on check list.



15197
17471



3. Check condition of drive wheels and tires. Note any apparent drive wheel or tire damage on the check list.

Check drive tire pressure and adjust, if necessary, to pressures listed on page 35.

4. Check condition of steer wheels and tires. Note any apparent steer wheel or tire damage on the check list.

Check steer tire pressure and adjust, if necessary, to pressures listed on page 35.

17620
17472



Before Operation

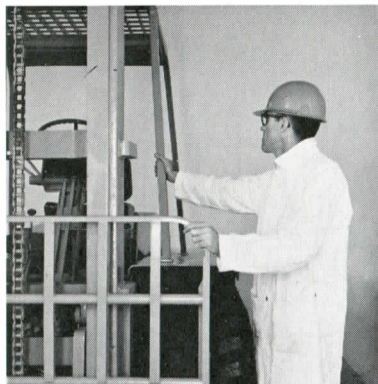

17473
17475

5. Check condition of overhead guard and load backrest extension.

Make certain that they are undamaged properly positioned and mounted securely.

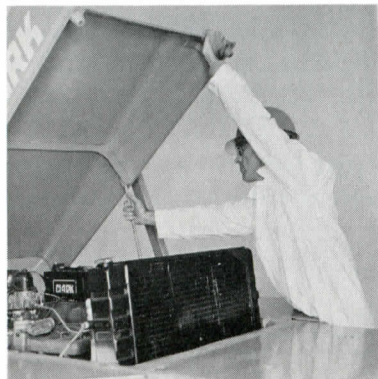

7. Lift the hood up and forward to the full open position and hold with your left hand.

Place hood support rod in place as shown and let hood down on the support rod.

6. Walk to back of the truck, insert the fingers of your left hand thru the grille and release the hood hold down latch.

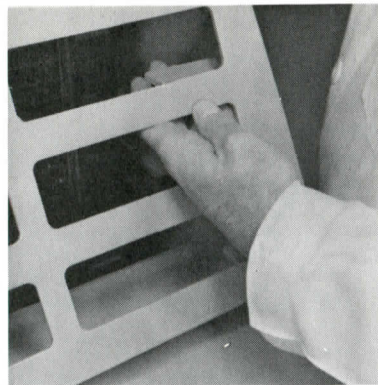

17474
17476

8. Visually check the general condition of the engine compartment.

Note condition of fan, belts, hoses, wiring, fittings, etc. Mark your check list to indicate your findings.

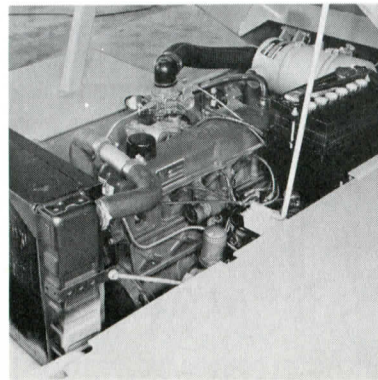

Before Operation

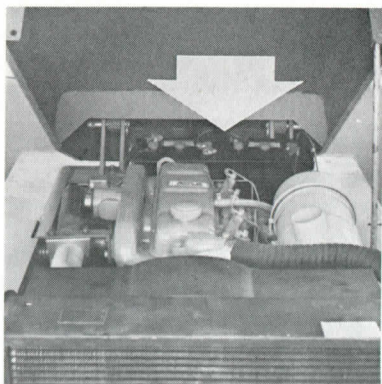

17817
17525

9. Visually check the general condition of battery (two on diesel models), battery terminals, and cables.

Note the condition of these items on your check list.

10. Gas models have a swing out battery feature. The battery must be lifted slightly with both hands and then pulled toward you with left hand.

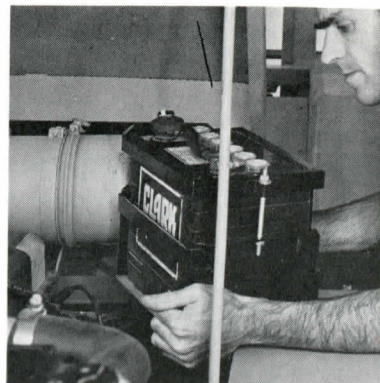

17524
17477



11. Remove fluid level plugs from all battery cells and check the fluid level in each cell. Add distilled water to each cell as required, replace plugs and swing battery back into place.

12. The engine oil dipstick, on gas models, is located as shown at right. Pull the dipstick from its support tube, wipe it clean with a lint free cloth and reinsert it fully into its support tube.

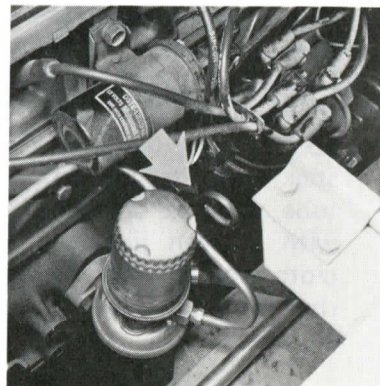

Before Operation

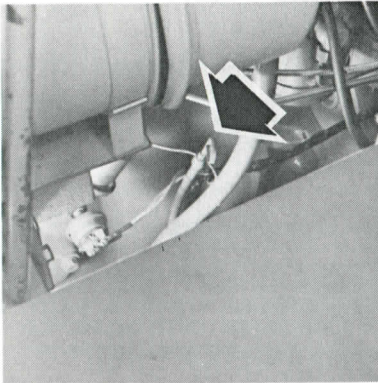

17818

13. If your truck is diesel powered, the engine oil dipstick is located as shown above. Pull the dipstick from its support tube, wipe the dipstick with a clean lint-free cloth, and reinsert the dipstick fully into the support tube.

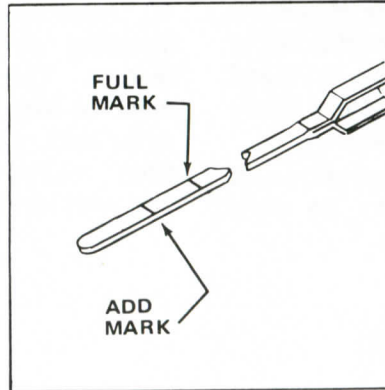

13239

14. After completing step 12 or 13, pull the dipstick from the support tube and check engine oil level.

Oil level must be maintained between "add" and "full" marks on the dipstick.

Remember that one quart of oil will raise the oil level from "add" to "full" — DO NOT OVERFILL.

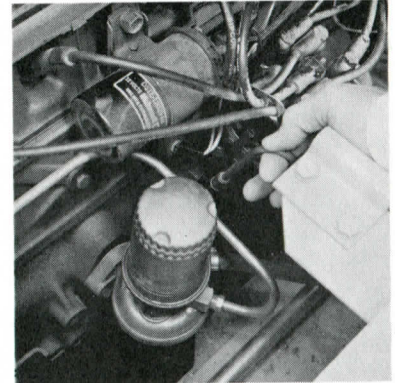

17505

15. Wipe the dipstick once again with a clean, lint free, cloth and reinsert the dipstick fully into its support tube.

Before Operation

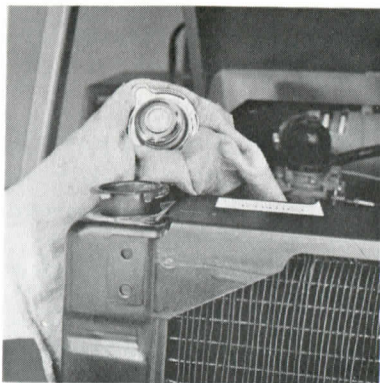

17506
17507

16. Always check radiator coolant level with engine turned off and cold, if possible.

Caution — Use extreme care when removing radiator pressure cap. The sudden release of pressure can cause a steam flash resulting in serious injury. Place a rag over the radiator cap and loosen slowly to allow gradual escape of steam.

Never add cold water or cold anti-freeze into the radiator of an overheated engine. Allow the engine to cool and avoid the danger of cracking the cylinder head or block. Keep engine running while adding water or anti-freeze. A solution of 50% ethylene glycol and 50% water is recommended — never use water only.

Remember to replace radiator cap and make certain that it is properly secured after check of radiator coolant level has been completed. Then return the hood prop to its "carry" position and carefully close the hood. Make certain that the hood latches in the closed position.



17. Remove blocks from drive wheels, carefully enter operators compartment and seat yourself in the operators seat.

18. Seat adjustment is accomplished by releasing short lever at lower right front of seat.

Position seat to provide easy access to all hand and foot controls, free lever and make certain that seat locks into desired position.

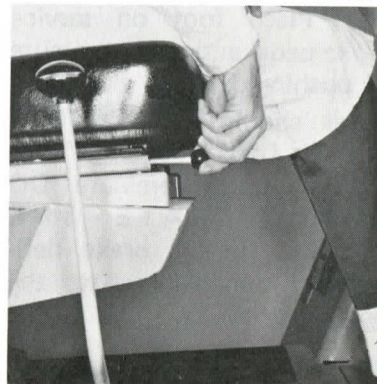

17508

Before Operation

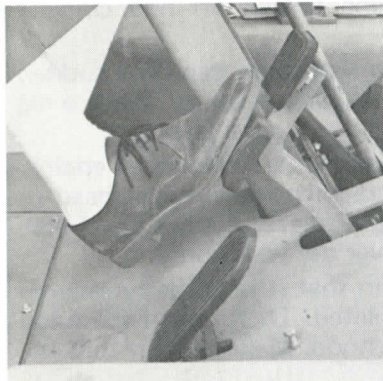

17509

19. Place foot on service brake pedal and apply pressure by pushing down.

Pedal should be "firm". If pedal feels "spongy" or "fades" under pressure DO NOT OPERATE THE TRUCK. Report brake deficiency immediately to the proper authority.

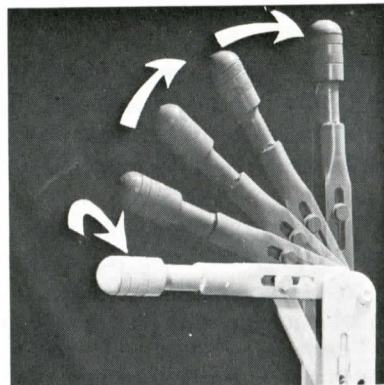

13228

20. Make certain the parking brake lever is in the "on" (full-up) position.

Brake holding power can be adjusted by rotating the knob on top of the lever clockwise to increase holding power or counterclockwise to reduce it. (See page 35 of this manual for holding specifications).



17510

21. Check transmission speed range shift lever to make certain that the transmission is in neutral.

Before Operation

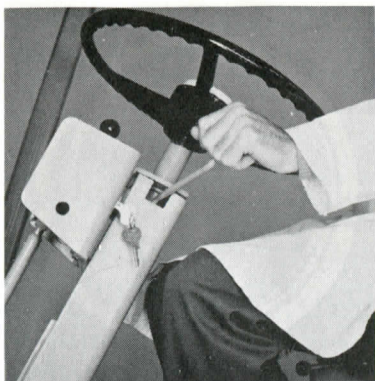

17511

22. Check to make sure that transmission directional control lever is in neutral position. These trucks are equipped with a neutral start switch and cannot be started in forward or reverse unless switch is faulty or improperly adjusted. Report switch condition on your check list.

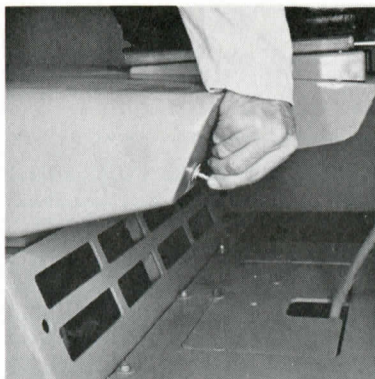

17512

23. Gas and L.P. gas trucks are equipped with a manual choke. This control must be pulled when starting a cold engine.

On L.P. gas models the choke should be pushed in as soon as the engine starts. On gas models the choke should be pushed in gradually as the engine begins to warm up once started. (Refer to page 39 for cold start procedures on the diesel powered models.



17513

24. Place your right foot on the accelerator pedal and press down slightly.

Before Operation

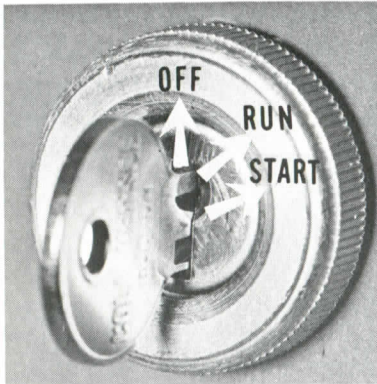

13226

25. Insert ignition switch key and turn clockwise to "start" position.

Release key to return to "run" position as soon as engine starts.

If engine does not start on the first attempt, return the key to the "off" position and do not reengage the starter until the engine comes to a complete stop (approx. 5 sec).

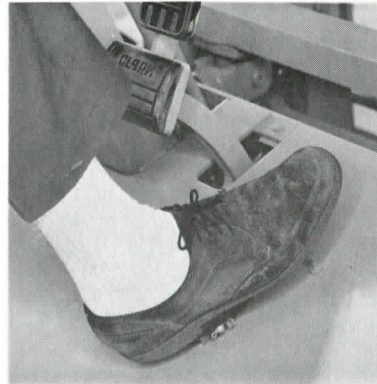

17523

26. If gas or L.P. gas engine becomes overchoked or "flooded" in starting, push choke control in — press accelerator pedal to floor board and engage the starter as described in item 23.

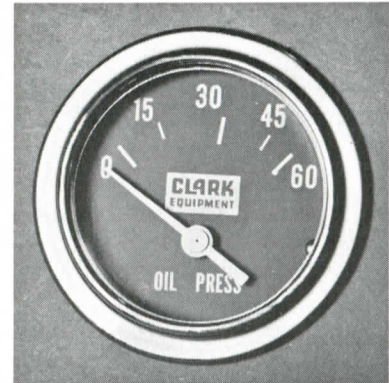

13222

27. Check the dash mounted engine oil pressure gauge to make certain that it is undamaged and operating properly. The oil pressure should not drop below 7 PSI at idle. If oil pressure is erratic or if it drops below 7 lbs. you should stop the engine immediately.

Before Operation

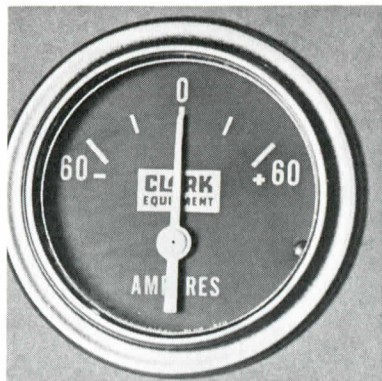

13224

28. Check the ammeter for proper operation. It should indicate a high rate of charge for a short period of time after the engine starts.

If the ammeter shows a continuous high rate of charge, discharge, reads erratically, or is otherwise damaged you should record these facts on your check list.

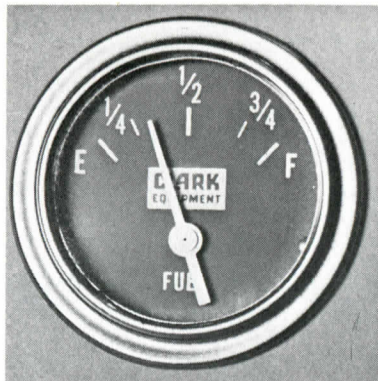

13220

29. Check the fuel gauge to determine the amount of fuel in the tank.

It is recommended that you always start your shift with a full fuel tank. This is especially important on diesel models as it is possible to severely damage the injection pump and nozzles when a diesel runs out of fuel.

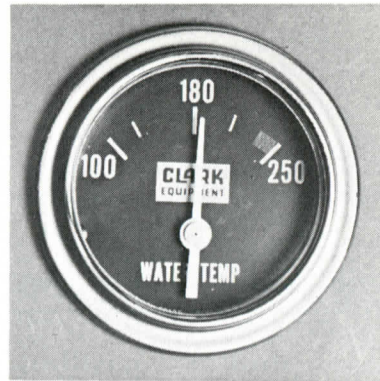

13223

30. Check dash mounted water temperature gauge to insure that it is undamaged and functioning properly. Water temperature should reach 180° F. after 10 minutes of operation.

If the indicator needle goes into the "hot" or red area during operation — immediately shut down the engine and do not restart until cause of trouble has been located and corrected.

Before Operation

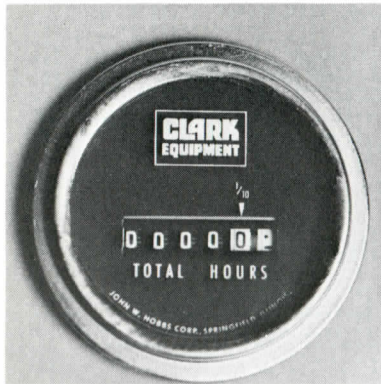

13225

31. The engine hour meter is mounted on the right hand side of the truck above the fuel filler cap.

Make certain that it is undamaged and operating properly. Notice the total hours on the meter and record them on your Daily Check List.

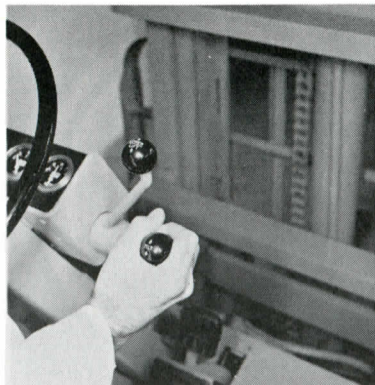

17514

32. Gently pull back on the tilt control lever and hold until upright reaches full back tilt.

Do not hold lever back after upright has reached full back tilt — to do so will unduly heat the hydraulic fluid and could harm the hydraulic system components.

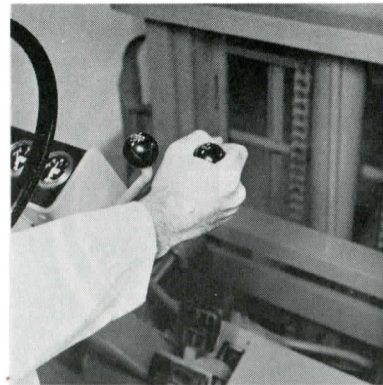

17515

33. Push tilt lever forward and hold in position until upright tilts forward to near vertical position.

Return tilt lever to neutral position to halt forward tilting action at desired point.

Before Operation

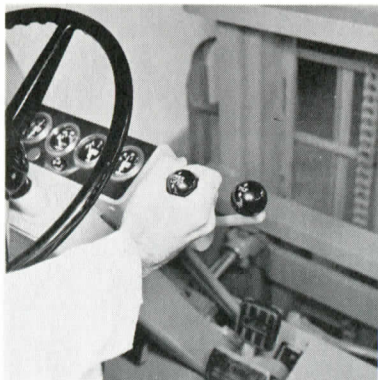

17467

34. Carefully check the adequate unobstructed overhead clearance, then gently pull back on lift control lever and hold until upright reaches maximum lift height.

Return lift lever to its neutral position to halt lift at desired level.

Note any erratic upright operation on your check list.

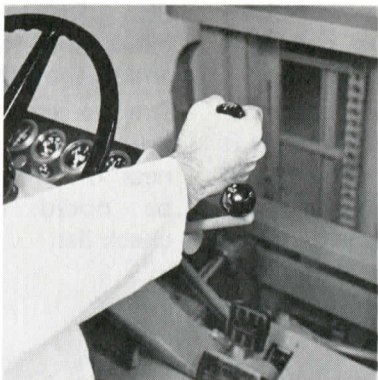

17468

35. Gently push forward on lift control lever and closely observe descent of upright carriage.

Return lift control lever to its neutral position to stop upright descent near (about 4-6 inches) floor level.

Record any erratic or unusual operation on your check list.

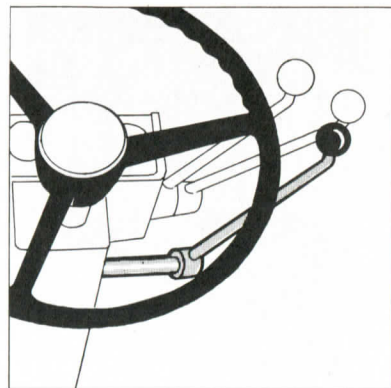

17626

36. Trucks equipped with hydraulic attachments or accessories will have one or more additional control levers mounted to the right of the lift and tilt control levers.

The function(s) of these levers should be checked with your supervisor before attempting operation.

Before Operation

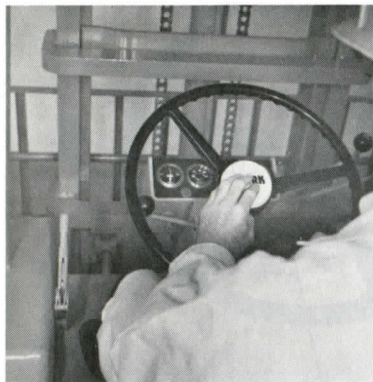

17516
17464

37. Press horn button to determine if horn is operational.

If horn does not function properly record it on your check list and report it to the designated authority when you have completed your "before operation" checks.



39. Check all around truck to make certain that your desired path of travel is unobstructed.

38. Rotate steering handwheel to the left and to the right.

Any excessive or unusual free travel, looseness or binding must be noted on your check list.

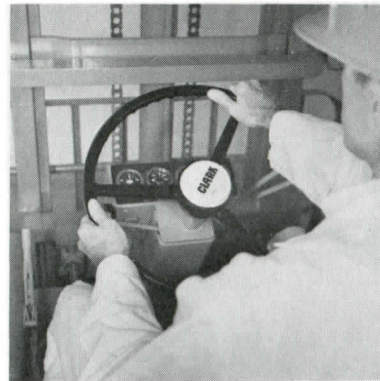

17517
17509

40. Place your right foot on the brake pedal and press down firmly to apply the truck service brakes.

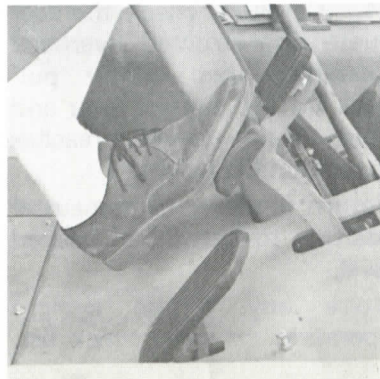

Before Operation



17518
17511

41. Release the parking brake by pushing forward on the brake control lever located immediately inboard of the left hand drive wheel fender.

42. Place your left foot on the transmission dump (clutch) pedal and apply downward pressure to "dump" oil from the clutch packs. This will enable you to easily shift the transmission speed range lever.



17520
17519

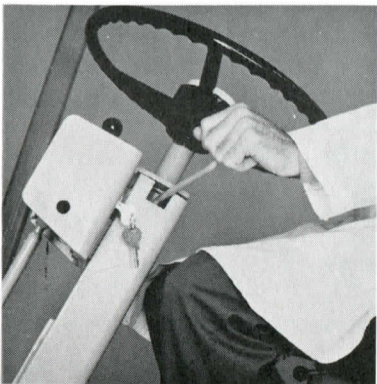

43. Place forward-reverse shift lever into proper position for desired direction of travel. (Pull lever back for reverse or push it forward for forward travel).

44. Place transmission speed range selector lever in the low gear (1st) position.

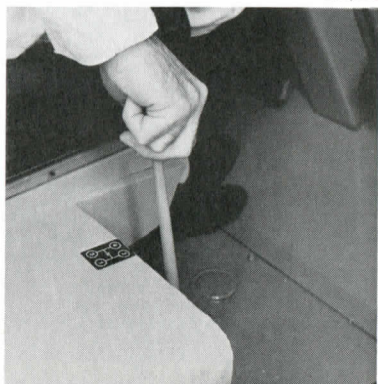

Before Operation



17520
17509

45. Slowly and smoothly engage (release pedal) the transmission dump (clutch) pedal with your left foot.

46. Release foot pressure on the service brake pedal and place your right foot on the accelerator pedal. Gently push the accelerator pedal downward until the truck begins to move.

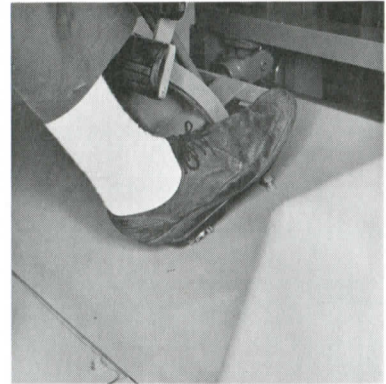

17513
17521

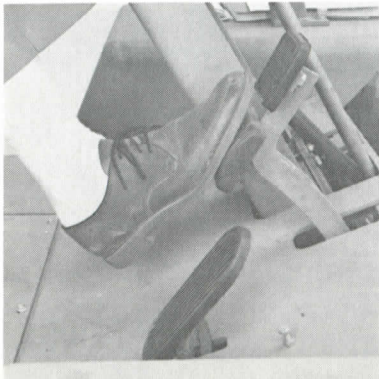

47. ... Then release the accelerator pedal and place your right foot on the brake pedal and apply pressure to the brake pedal to bring truck to a smooth stop.

48. Move forward-reverse shift lever for direction opposite that selected in item 41 and repeat steps 43, 44, and 45.

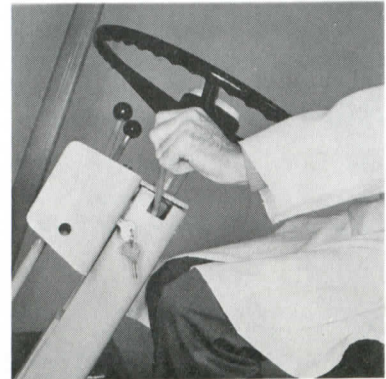

Before Operation

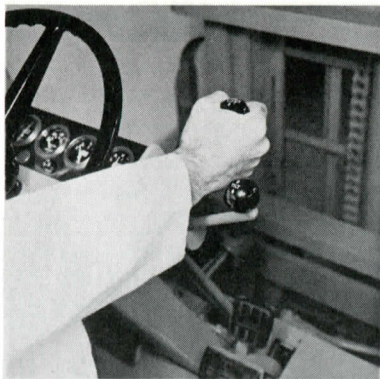

17468
17518

49. Lower lift forks to the floor and . . .

50. Tilt the upright forward slightly to place the fork tips on the floor.

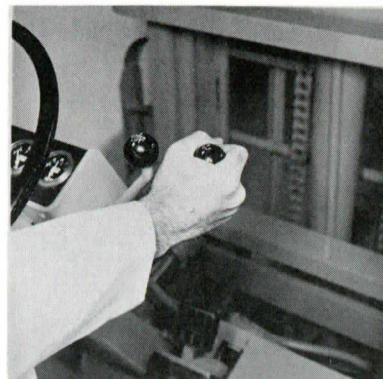

17515
17819

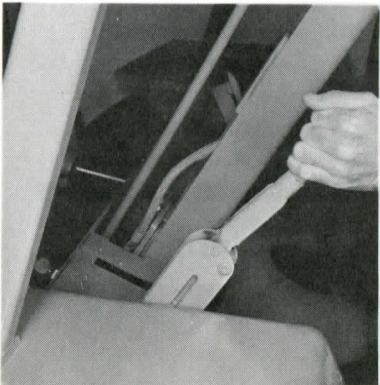

51. Place the forward-reverse directional control lever in neutral and apply the parking brake by pulling the lever toward you.

52. If your truck is diesel powered — pull engine stop control and hold until engine comes to a complete stop — then push stop control into the "run" position.



Before Operation

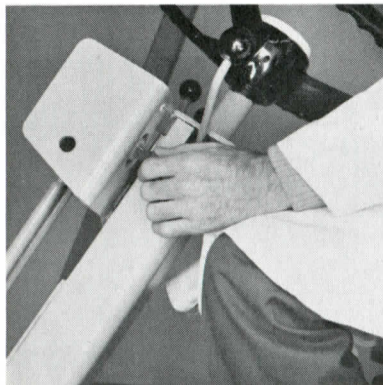

17469
17522

53. Turn switch key counterclockwise to the "off" position and remove the key from the switch.

54. Carefully dismount from the truck.



17507
15197



55. Securely block the drive wheels.

56. Review your check list to make certain that it is complete, sign it and turn it into the designated authority.



Operating Hints



17625

1. All models must be brought to a complete stop before shifting the directional control lever from forward to reverse or from reverse to forward.

- Always use low gear when starting, negotiating grades or ramps and when operating over rough or unimproved surfaces.
- Transmission speed ranges may be changed while traveling. When "upshifting" these trucks it is necessary to fully depress the transmission dump (clutch) pedal, shift to next higher gear and then release the transmission dump (clutch) pedal with a smooth, steady motion while properly regulating engine speed to obtain maximum smoothness.
- Whenever it becomes necessary to "down-shift" into a lower gear, depress the transmission dump (clutch) pedal fully, move the range shift lever into the next lower gear and release the transmission dump (clutch) pedal while regulating engine speed to obtain maximum smoothness.

- Selecting the correct drive gear ratio is a very important operators function. Choosing the proper gear for the job being done will result in better truck performance with longer engine and transmission life.
- If the operating surface is rough, or soft, or if grades or ramps must be negotiated, use the lowest transmission gear ratios available to you because — here power is needed — speed is not.
- As a general rule of thumb — DO NOT Lug the engine. Overworking the engine thru use of a "too high" gear ratio will create excessive heat and shorten component service life.
- When in doubt — use next lower gear.

Operating Hints

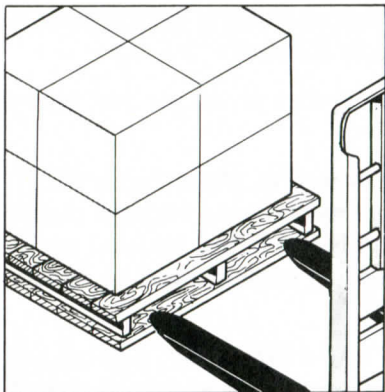

13203
10759

2. Remember to approach load slowly and squarely to avoid damaging the material being handled and to minimize truck maneuvering.

Load should be centered and forks should be near the outside edges to improve stability — if they are not . . .

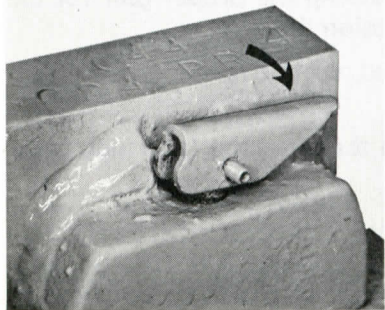

4. . . . Remember to lower lever to lock forks securely into notch atop fork bar.

3. . . . Adjust them by lifting fork lock lever and sliding forks to the desired position then . . .

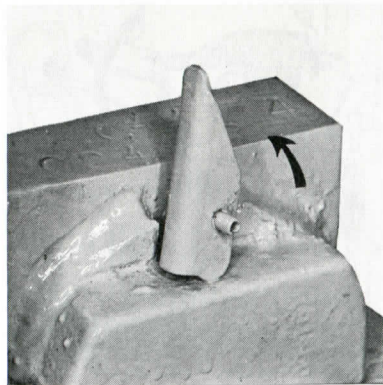

10758
17465

5. Always be alert for abrupt changes in the operating characteristics of your truck.

Unusual noises or sudden changes should be reported to your supervisor immediately.



Operating Hints

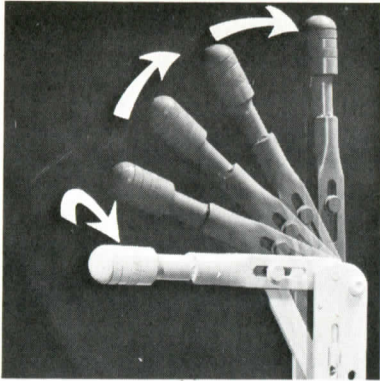

13228

6. Parking brake performance is checked by moving lever from full "on" position to full "off" position. Maximum force will be required just before brake lever reaches full "on" position.

The parking brake should be adjusted to hold the truck, with capacity load, on a 15% grade (1.5 feet of rise in 10 feet), or on the maximum grade negotiated in your operation, whichever is less. Brake holding power can be adjusted by rotating the knob on the lever. Rotate it clockwise to increase tension or counterclockwise to decrease tension and holding power.

TIRE PRESSURES			
Tire Size	Ply	P.S.I.	KPa
15 x 19.5	10	60	413
15 x 19.5	14	75	517
12 x 16.5	8	40	275
12 x 16.5	10	60	413
18 x 19.5	10	60	413

GASOLINE

SPECIFICATIONS — Fuel to be Automotive Quality Regular Grade Gasoline containing a corrosion inhibitor.

Minimum Motor Octane
Number — 85

Operating Hints

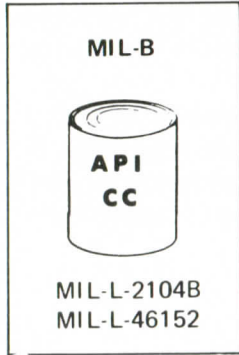

GAS – L.P. GAS ENGINE OIL

SPECIFICATION To meet API Service Classification "CC" and "SC" per SAE Report J183 and/or MIL-L-2104B. Sulfated ash content 1.00% weight maximum. Zinc content 0.06 to 0.10% weight maximum.

This specification includes oils meeting Specification MIL-L-46152 when applicable. Also, API Service "SC"/"SD" (Formerly "MS") oils may be preferred under stop-and-go or light service conditions.

• ENGINE CRANKCASE OIL

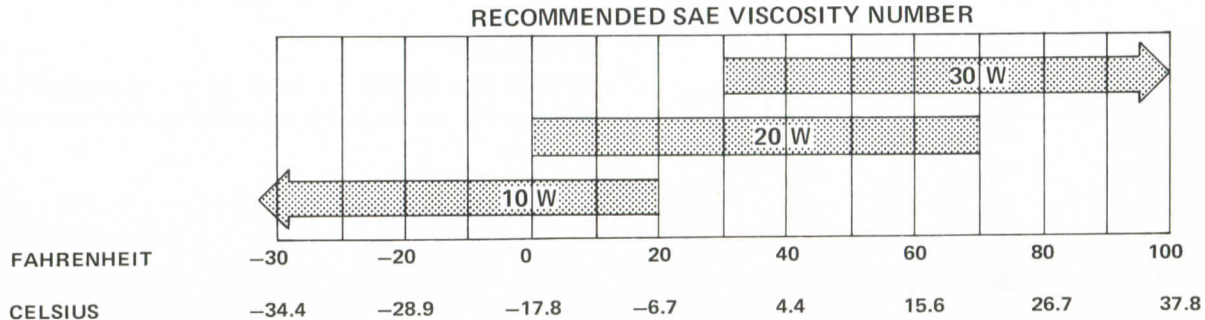

Operating Hints

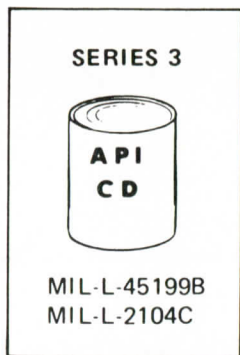

For . . . diesel engines using high sulfur content fuel (over 0.5% sulfur).

SPECIFICATION To meet API Service Classification "CD" per SAE Report J183 and equivalent Series 3 and/or MIL-L-45199B specifications. Also MIL-L-2104C when applicable. Sulfated ash content 1.65% maximum.

SAE #30 oil of MIL-L-2104B performance level is recommended for year around use in Detroit diesel engines . . . (Limitations – zinc, 0.10% maximum.). The use of Multi-grade oils in Detroit diesel engines is not recommended.

• ENGINE CRANKCASE OIL

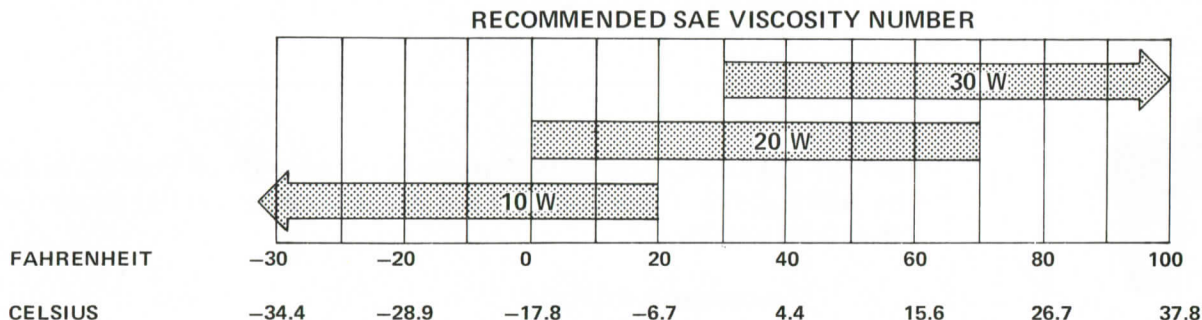

Operating Hints



GASOLINE

SPECIFICATIONS Fuel to be Automotive Quality Regular Grade Gasoline containing a corrosion inhibitor.

Minimum Motor Octane
Number – 85

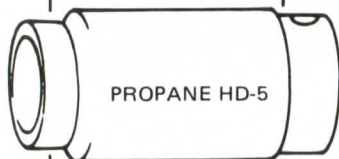

L.P. GAS

SPECIFICATIONS Use LPG meeting PROPANE HD-5 (NGPA Specification 2140-62) or ASTM D2154 (Special Duty Propane) requirements.

Minimum Motor Octane
Number – 95



DIESEL

SPECIFICATIONS Fuel to be Automotive Quality Diesel Fuel Oil as defined by ASTM D975, Grades No. 1-D and 2-D, and having a sulfur content of less than 0.5% weight.

Recommended Cetane
Number – 45 Minimum

Operating Hints

All diesel powered trucks are equipped with a "thermostart" cold starting aid feature which is operated by a button located below the left front corner of the operators seat. To accomplish cold weather starts you should proceed as follows:

1. ● – Check engine stop control to make sure that it has been pushed into the engine "run" position.
2. ● – Turn switch key clockwise to the "on" position.
3. ● – Press firmly on the "thermostart" button and hold the button in for 15 to 20 seconds.
4. ● – Push the accelerator pedal all the way down and turn the switch key clockwise to the "start" position to engage the starter motor.
5. ● – If the engine does not start after 15 seconds, return the key to the "off" position and repeat steps 2, 3 and 4.
6. ● – As soon as the engine starts release the key which will automatically return to the "run" position.

Parking

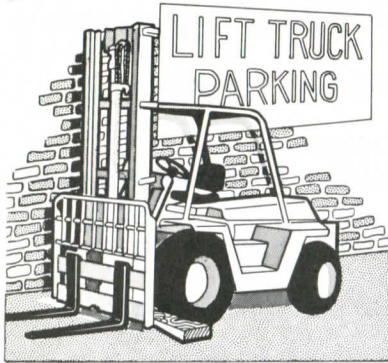

17623

1. Park lift trucks only in designated parking areas. Do not block aisles, exits, entrances or other emergency lanes.

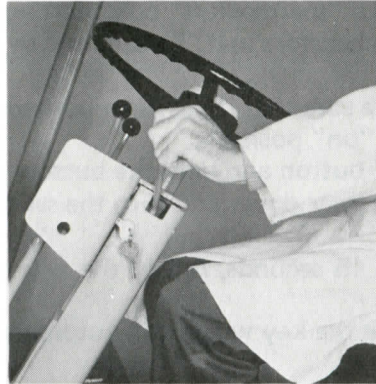

17521

2. Make certain that transmission directional selector lever is in the neutral position.

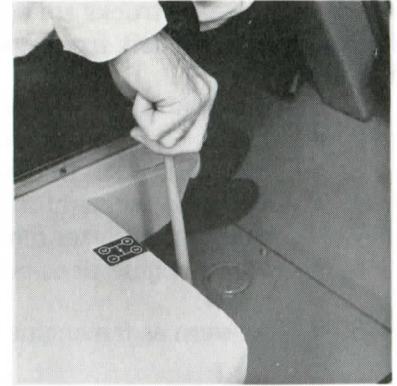

17519

3. Make certain that transmission speed range selector lever is in the neutral position.

Parking



17518

4. Apply the parking brake.

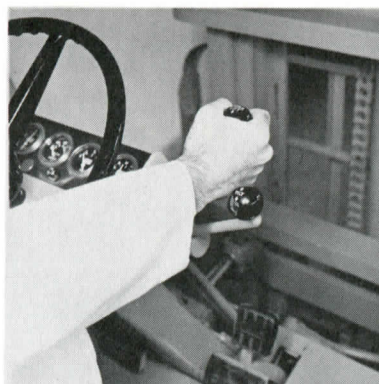

17468

5. Lower upright so that lift forks are at floor level.

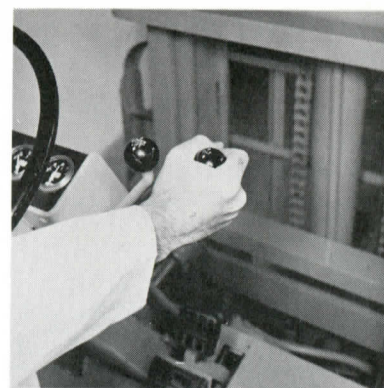

17515

6. Tilt upright forward slightly so that fork tips will be closer to the floor.

Parking

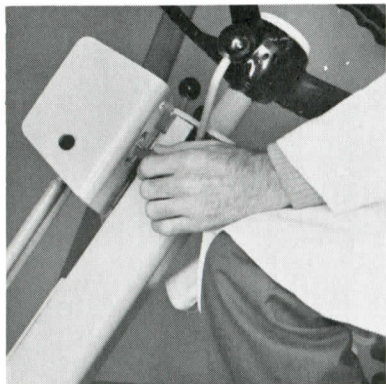

17469

7. Turn ignition switch key counterclockwise to the "off" position and remove the key from the switch.

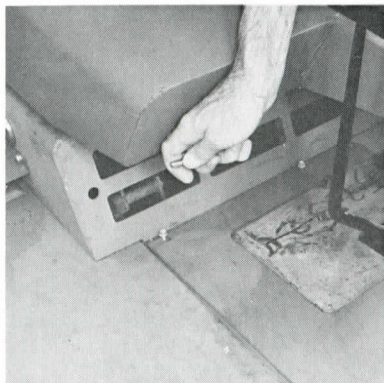

17819

8. If your truck is diesel powered it will be necessary to pull the engine stop control and hold it until the engine stops prior to removing the key.



17507

9. Carefully dismount from the truck and don't forget to block the drive wheels securely and turn the key into the designated authority.

For Handy Reference

RECORD THE FOLLOWING INFORMATION PERTAINING TO YOUR TRUCK

Model _____

Serial No. _____

Attachments _____

Truck Weight (Empty) _____

Truck Rated Capacity _____

Gross Truck Weight (With Rated Load) _____

Transmission Type _____

Fuel Type (Gas, L.P. Gas or Diesel) _____

Tires (Pneumatic, Cushion) _____

Type Controls (Console or Column Mounted) _____

Customer Truck Identification _____

CLARK EQUIPMENT COMPANY
INDUSTRIAL TRUCK DIVISION
CUSTOMER SERVICES GROUP
BATTLE CREEK, MICHIGAN 49016

Additional copies of this manual may be purchased from:

**YOUR AUTHORIZED CLARK
DEALER**