



OPERATOR INSTRUCTIONS

EM 10-12-15S

Rated Capacity: 1000-1500 kg



01-507

Illustrations, descriptions, diagrams and other particulars only serve for elucidation and presentation of the text. They are not binding as regards details of construction, installation or delivery. We do not undertake liability for conformity of the text with national or local regulations. Subject to revision.

CLARK Material Handling Group

OPERATOR INSTRUCTIONS EM 10-12-15 S

Rated Capacity: 1000-1500 kg

OI-507 GEF E REV JUN 86

**CLARK EQUIPMENT GMBH
TECHNICAL SERVICE (EUROPE)**

**Weseler Str. 48-50
D-4330 Mülheim (Ruhr)**

Contents

	Page
Please Note	3
General Description	4-5
Description of Components	6-9
Safety Regulations	10-19
Know Your Fork-Lift Truck	20-26
Before Starting	27-30
Operating Instructions	31-32
Maintenance and Care	33-53
Lubrication and Maintenance Chart	54-55
Lubricant Recommendation	56
Technical Data	57

All technical data and all illustrations in these Operating Instructions are without obligation. We reserve the right to make alterations in the interests of technical progress.

Foreword

Performance and economics of the forklift truck depend to a great extent on its proper handling as well as on the regular maintenance and care. The following operating instructions should help you to prepare the necessary conditions. We recommend, therefore, that you read the instructions carefully and follow strictly the given procedures. Get yourself acquainted with the operating components and observe especially the safety regulations. Carry out all maintenance and care work at the recommended time intervals. The CLARK forklift truck has been designed for ease of maintenance. You should be able to carry out all work in a relatively short time and without great effort.

Regular maintenance and care of your forklift truck is not only recommended for economical reasons, but moreover because of the safety requirements. A faulty forklift truck represents a potential source of danger. The respective accident prevention regulation for forklift trucks may state the following.

Forklift trucks should be checked at least once a year by an authorized expert.

Your local CLARK distributor has specially trained service personnel who are authorized to check the forklift truck in accordance with the respective accident prevention regulations.

Do not only contact your local distributor for the yearly check or in the case of an urgently required repair job. Turn to him with confidence in all questions relating to maintenance and care.

He will offer you a maintenance contract, which will be carried out by trained and competent service personnel and which will guarantee the continuous reliability of your fork-lift truck. However, should you want to carry out your own maintenance and care, your local distributor stocks all the necessary spare parts, as well as any maintenance and care materials you may require. Now also remember our original CLARK spares will ensure perfect performance and optimum economics. There is no substitute for original CLARK spares. These are quality controlled for accuracy and material just the same as those parts being used in the continuous production of our fork lift trucks.

Furthermore we would like to bring to your attention that the Clark warranty excludes repairs necessary due to misuse of the equipment, insufficient maintenance, of the use of other than genuine Clark replacement parts.

General Description

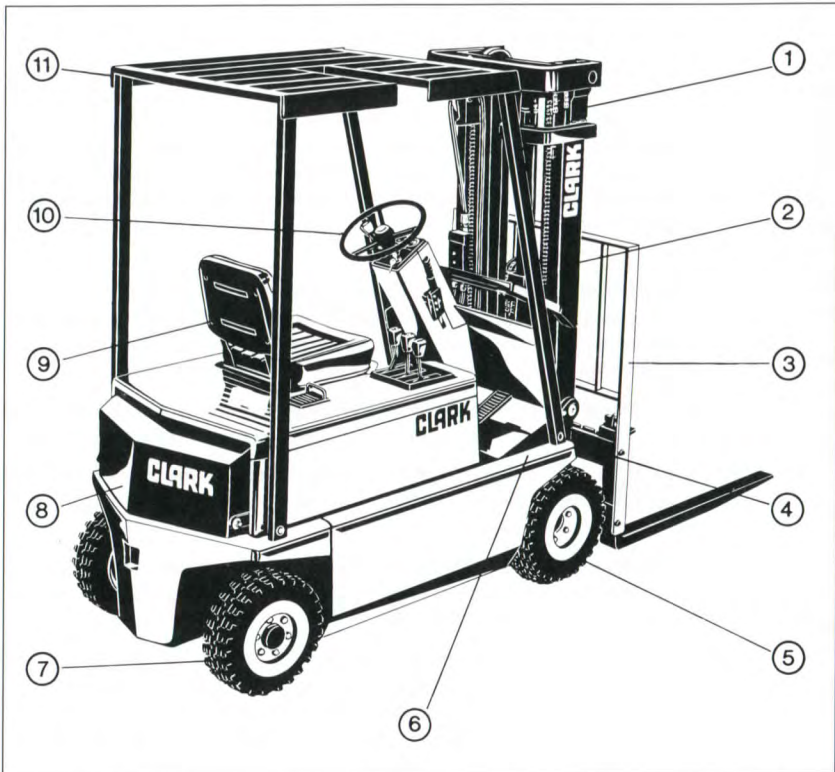

26205

Clarklift EM 10-12-15 S Load capacity: 1000-1500 kg

1. Upright
2. Upright model- and serialnumber
3. Load back rest
4. Fork carriage
5. Drive axle wheel
6. Truck model- and serialnumber
7. Steering axle wheel
8. Counterweight
9. Driver's seat
10. Steer wheel
11. Driver's overhead guard

General Description

The Clarklift EM 10-15 is a high performance, highly manoeuvrable four wheeler fork lift truck with electric drive and electronic control. Its capacity corresponding to the type of the series is 1000 kg, 1250 kg and 1500 kg. The truck is fitted with hydraulic disc brakes and servo assisted steering. It receives its enormous performance capabilities from a 48 V battery, two DC series wound drive motors as well as a pump/motor unit and a motor for power assisted steering. The truck is driven by the two drive motors transferring power via an oil immersed gear arrangement to the power wheels. The newly designed steer axle facilitates an extremely tight turning circle (wheel inner 81°).

This new design offers turning circles as follows: EM 10 1634 mm, EM 12 1740 mm and EM 15 1855 mm. The power assisted steering together with the ergonomic arrangement of the driver's seat and control components reduces tired-

ness from driving even over longer time spans. Furthermore, the driving controls are arranged the same as for cars. This arrangement allows quick and safe familiarisation for the driver. The new design of the lift attachment ensures good forwards visibility. Considerable emphasis was put onto the prevention of pinch or sheer in positioning of the lift attachment. The Clarklift EM 10-15 electronically controlled (impulse control). This method facilitates a power saving control of the driving speed, from start to maximum speed. Furthermore, extremely sensitive and jerkless starting and braking is possible.

The electronic control enables greater load capacities per battery charge to be handled as well as more gentle stressing of motors and gears. The impulse control works practically without any wear or tear and, therefore, requires only the minimum in maintenance.

Description of Components

Drive Motors

Both drive motors are DC series wound motors. They are protected against dust and moisture. The change in rotation is effected by actuating the direction lever changing the poles of the field winding. The motors are flanged

by means of their front bearing plate direct to the drive. The motor casing is provided with openings, which are covered by a metal band during operation, enabling the carbon brushes to be checked or exchanged.

Description of Components

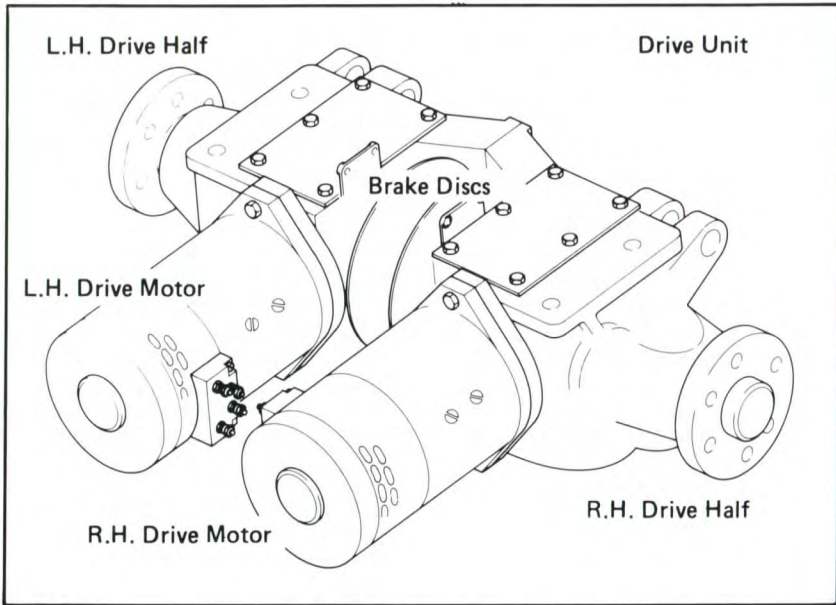

19511

Transmission

The drive of the Clarklift EM 10-15 comprises two drive halves, which are bolted together to form one unit. Each drive half has its separate power input. The power is transferred from the drive motor via a hypoid cone gear and bevel gear to an intermediate shaft and from there via spur wheel to the drive shaft and onto the drive wheel. Both drive halves run noiseless in an oil sump.

Battery

The battery of your Clarklift EM 10-15 is an energy store, storing electrical energy in the form of chemical energy, which in turn is passed on in the form of electrical energy. The battery consists of a

number of interconnected cells housed in a steel casing. The individual cells are filled with an electrically conducting fluid (electrolyte). Recharging of the battery is by means of DC via a battery charger. The battery has a capacity of 300 Ah for the AM 10 version, 400 Ah for the EM 12 version and 500 Ah for the EM 15 version.

Control Panel

Impulse controlled thyristors instead of the hitherto used relays and resistors are employed in the electronic control system of the Clarklift EM 10-15. The individual components of the control system are mounted on one control panel to form a compact

Description of Components

control unit. All parts become easily accessible and maintenance and care operations are facilitated.

Steering

The Clarklift EM 10-15 is fitted with hydrostatic power steering, requiring no mechanical linkage between the steering wheel and the

steered wheels. In such a system a gear pump conveys oil into the steering drive — and with a non-actuated steering wheel back into the tank. On turning the steering wheel, oil is pushed into the steering cylinder according to the turning direction, effecting the steering lock.

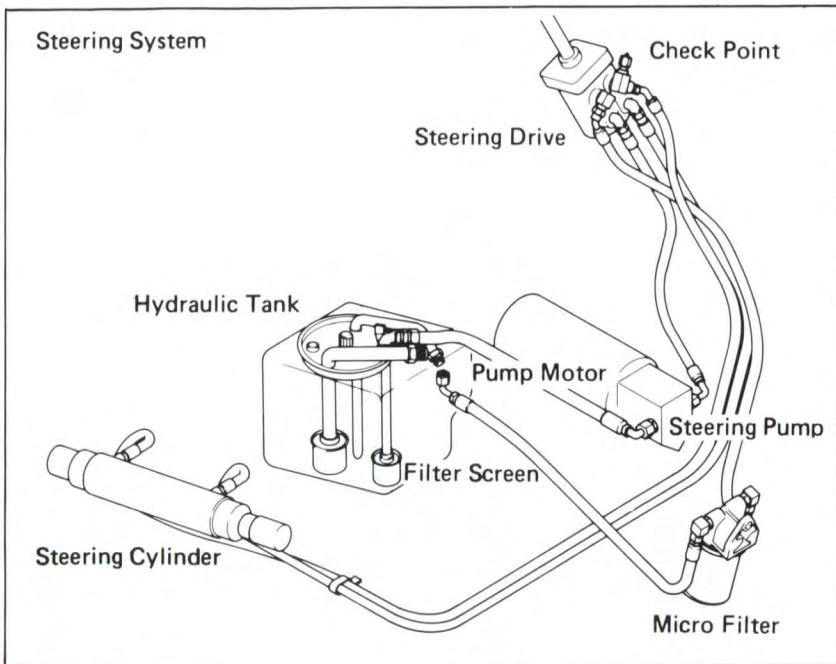

21339



Your **CLARK** Dealer
keeps all lubricant
available for you

Description of Components

Parking Brake

The parking brake works on the knee lever principle and acts by means of a cable upon the discs of the service brake and in turn upon the drive wheels. The parking brake can be adjusted on the brake lever.

Caution: Adjustment of the parking brake should only be undertaken by a competent mechanic. With the brake lever in the pulled-on position the supply to the drive motors is broken via a micro-switch.

Service Brake

The service brake of the Clarklift EM 10-15 is a hydraulic disc acting upon the drive wheels. With this type of brake the discs are mounted on the intermediate shaft of the drive. The braking effect is therefore greatly improved. The service brake is actuated as in a car by means of a foot pedal.

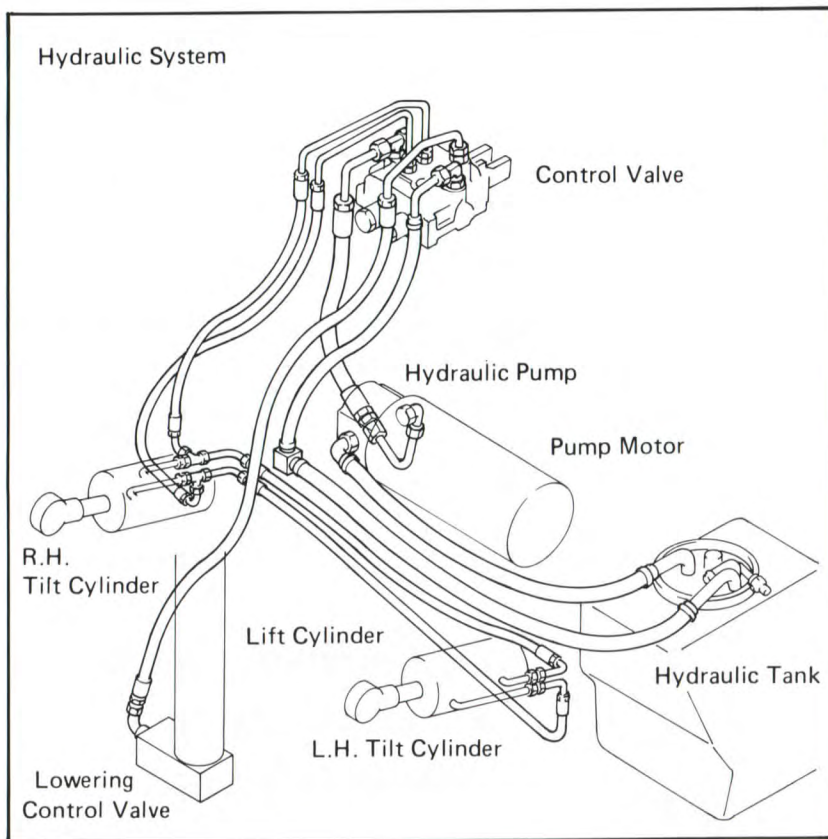

24664

Description of Components

Hydraulic System

The hydraulic system of the Clark-lift EM 10-15 utilises highly reliable and proven components. Besides the pump motor and its associated hydraulic pump there are: the control valve, lift cylinder, the tilt cylinder as well as the associated hydraulic hoses and the hydraulic tank.

On the control valve — for lifting as well as forwards and backwards tilting — microswitches are fitted actuating the pilot valves of motor and pump. The pump conveys oil to the control valve depending on the control setting and on to the lift cylinder or the tilt cylinders.

A tilt limiting valve is arranged on

the control valve preventing excessive tilt of the lift attachment. To prevent an uncontrolled or fast lowering of the load the lift cylinder is retarded by means of a release valve. A flow control valve on the main control valve regulates the supply of the required oil quantity for the selected control operation of the hydraulic system. The same kind of volume control valve is also incorporated for use with other attachments.

In addition to all this, the whole of the hydraulic system is protected against excessively high pressures by means of a pressure limiting valve built into the main control valve.

Use only genuine

CLARK

spare parts

Your CLARK Dealer

**keeps all spare parts
available for you**

Safety

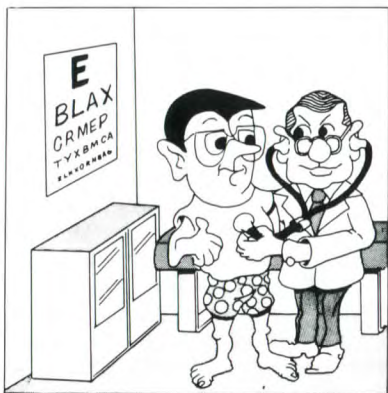

13696

Only trained and authorized personnel can operate Clark lift trucks.

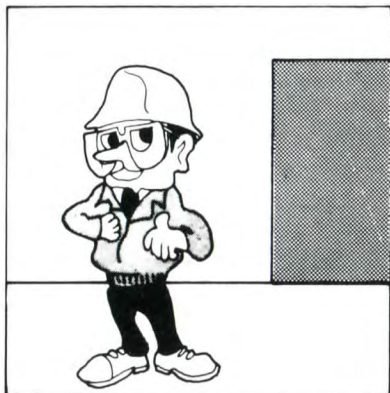

20277

Wear a hard hat, safety glasses and safety shoes when operating a lift truck. Do not wear loose clothing.



24287

Inspect your truck with the operator's daily checklist before you operate it. Make sure all safety systems work correctly. Do not operate a lift truck that has damage or is not safe. Make a report of decals that are missing or damaged and replace them immediately.

Safety



24288

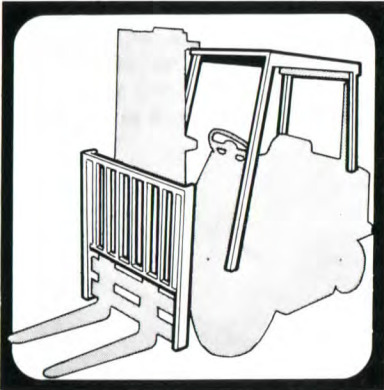

17638

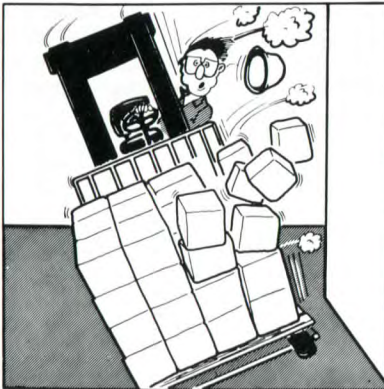

22292

Do not operate your truck in unauthorized areas. Follow all safety rules and read all warning signs. Slow the speed of your truck and use the horn near corners, exits, entrances, and near people.

Do not operate a lift truck without a load backrest extension or an overhead guard. These safety items are for your protection. Personal injury or death can result if you remove the overhead guard and load backrest extension from the lift truck.

Do not start, stop, travel, turn or change directions suddenly. Decrease speed for turns, ramps, aisles, wet floors or when visibility is not clear. Use caution when travelling without a load. Remember, operate your truck safely and avoid accidents.

Safety



17631

Do not raise personnel on the forks of your lift truck. A correctly designed safety cage must be used to raise personnel. The safety cage must be used to raise personnel. The safety cage must protect personnel from the lifting mechanism and restrain them inside of the cage. Do not transport personnel in the safety cage.

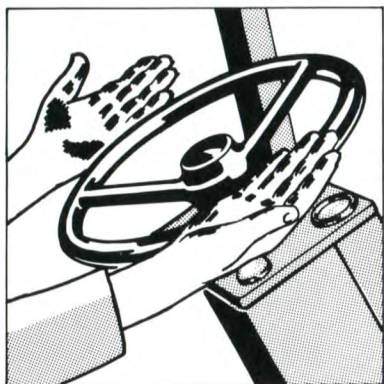

21370

Never operate a lift truck with wet hands or shoes. Never hold any controls with grease on your hands. Your hands or feet will slide off of the controls and cause an accident.



24289

Travel with the load tilted back and the forks as low as possible. This will increase stability to the truck and load and permit better visibility for you.

Safety

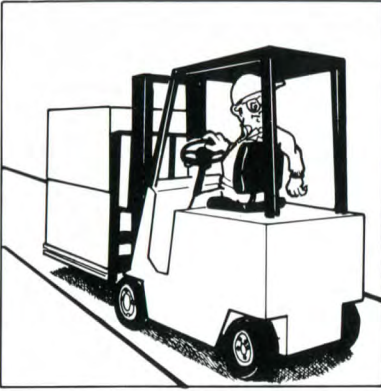

24290

Do not drive in forward direction when loads restrict your visibility. Operate your lift truck in reverse to improve visibility except when moving up a ramp.



24291

Do not go down ramps in a forward direction with a load on the forks. The steer wheels can raise off of the floor and cause an accident. Remember go up ramps forward and down ramps in reverse, when moving with a load.



24292

Do not turn when going up or down a ramp. The truck will lose stability and roll over and cause injury or death to personnel and damage to equipment. Travel slowly and operate the truck carefully on ramps.

Safety



21494

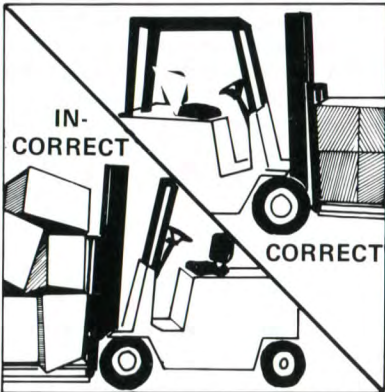

24295



24296

Do not move loads that are stacked higher than the load backrest extension. The load can fall and cause injury to you or other personnel.

Do not lift or move loads that are not safe. Make sure loads are correctly stacked and positioned across both forks. Operate slowly when moving long high or wide loads. Look out for other persons or obstructions in your path of travel.

Do not overload your truck or add extra counterweight to the truck. Know the rated capacity of your truck and its attachments. Never exceed the rated capacities. An overload can cause the truck to roll over and cause injury to personnel and damage to the lift truck.

Safety



24293

Do not raise or tilt the forks more than necessary when handling loads. Too much tilt can cause the load to fall or the truck to lose stability and roll over resulting in injury to personnel. Raise and tilt loads smoothly and carefully.



17635

Do not permit any one to stand or walk under the load or lifting mechanism. The load can fall and cause injury or death to anyone standing below.



24294

Do not lift or move a load unless both forks are fully under the load. Do not lift a load with one fork. Position the forks as wide as possible under the load. Handle loads carefully and check them closely for stability and balance. Remember, falling loads cause injury and damage.

Safety



24297

Do not travel with the load raised. The lift truck can roll over and cause injury or death to you or other personnel. Look out for overhead obstructions when raising or stacking loads. Be alert for falling loads when stacking.



24298

Be careful when operating a lift truck near the edge of a loading dock or ramp. The truck can fall over the edge and cause injury or death. Keep a safe distance from the edge and use caution when the floor is slippery.

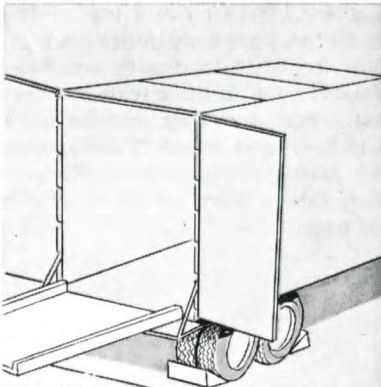

13146

Do not operate over bridge plates unless they are string and can support the weight of the truck and load. Make sure they are in the correct position. Put blocks on the vehicle you enter to keep it from rolling. Be careful, a lift truck can fall and cause injury or death.

Safety



24299

Do not operate a lift truck unless you are in the operators seat. Keep your hands and feet on the levers and controls and do not extend them past the operators area. Remember, operate your truck correctly and avoid injury.



24300

Do not let other personnel ride on the truck. They can fall off or cause you to have an accident. Lift trucks are designed to carry loads, not personnel.



22292

Operate your truck carefully to prevent an accident. Remember, safety first. Accidents can cause injury to persons and damage to the load and equipment.

Safety

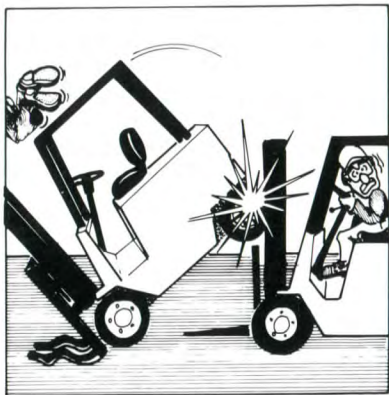

24301

Do not operate your truck close to another truck. You can cause an accident which will cause injury to personnel and damage to equipment. Keep a safe distance from other trucks and make sure there is enough distance to stop safely.



24302

Do not use your lift truck to push or tow another truck. Do not let another push or tow your truck. If a truck will not move, call a service technician.



24303

An operator must be in full control of his lift truck at all times. Look in the direction of your path of travel. Keep your hands and feet correctly on the controls. Operate your lift truck according to these safety messages and avoid accidents.

Safety

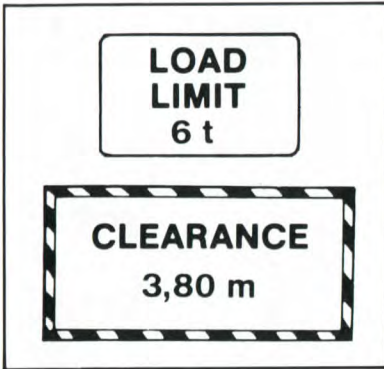

Observe all signs especially those on maximum permitted floor loading as well as clearance height. Observe all traffic signs. Watch out for on-coming traffic and drive especially carefully at pedestrian crossings.

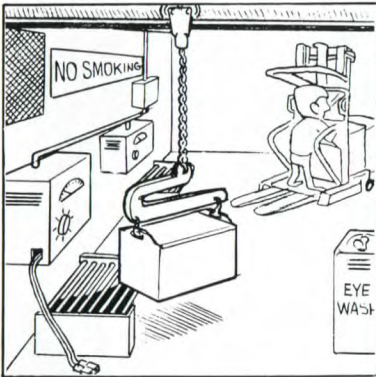

Recharging and maintenance of batteries should be carried out in specially allocated work shops and performed by qualified personnel only. With automatic recharging units recharging of the battery can be carried out by the driver.

Smoking in battery recharging shop or in rooms where fuel is stored is strictly prohibited.



Park your lift truck in authorized areas only. Fully lower the forks to the floor, put directional lever in "park" position and turn the key to the "off" position. Remove the key and put blocks behind the wheels to prevent the truck from rolling.

24304

Know Your Fork-Lift Truck

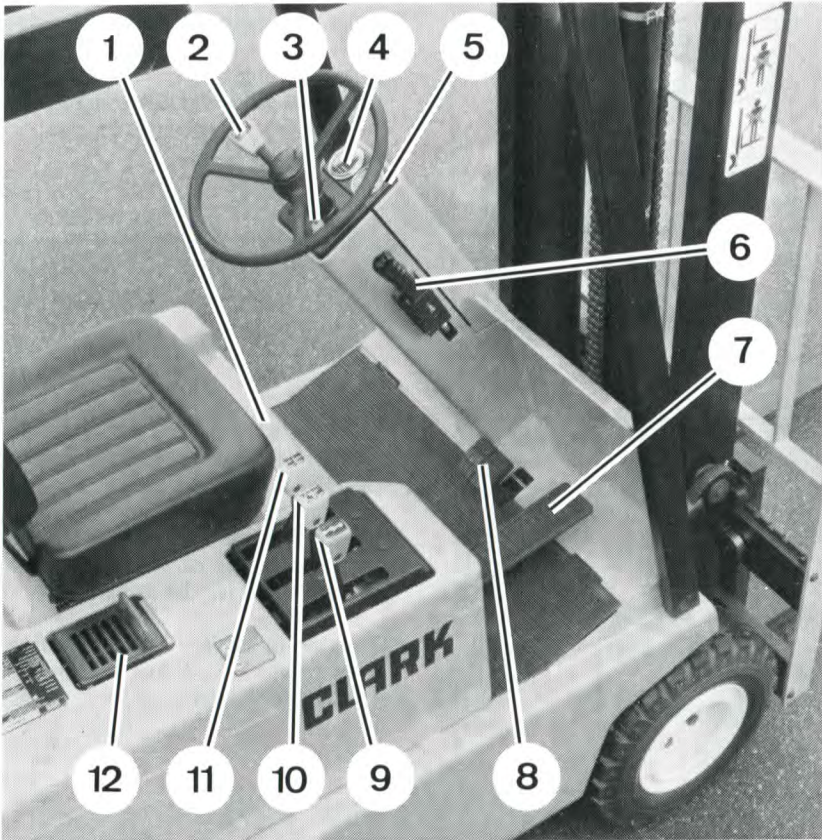

24665

CONTROLS

1. Seat Adjustment
2. Directional Control Lever
3. Key Switch
4. Hour Meter
5. Battery Discharge Indicator
6. Parking Brake
7. Accelerator Pedal
8. Brake Pedal
9. Lever for Additional Hydraulic Equipment
10. Tilt Control Lever
11. Lift Control Lever
12. Emergency Switch Off

Know Your Fork-Lift Truck

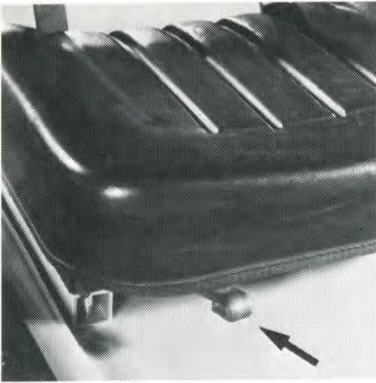

19531

Seat Adjustment

The driver's seat can be adjusted in the longitudinal axis. To do this push lever to the left. After the required position has been found, let go of the lever and ensure that the seat is locked in.

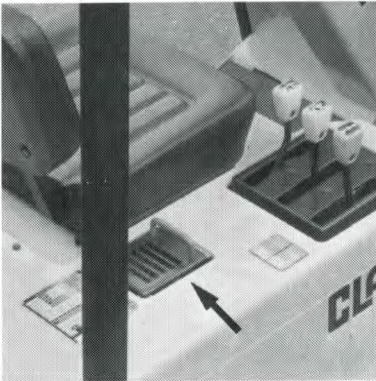

24666

Emergency Switch

Using the emergency switch separates the battery plug and breaks the electric supply. The emergency switch should be used in times of real danger only.



24667

Accelerator Pedal

Pushing the accelerator pedal down regulates the driving speed. An induction transducer is used as controller.

Know Your Fork-Lift Truck



24668

Key Switch

Switching-on and turning-off of the electric supply is by means of the key switch. To switch on, place the key in the lock and turn by 45° clockwise. To turn-off the current proceed in the reverse direction.

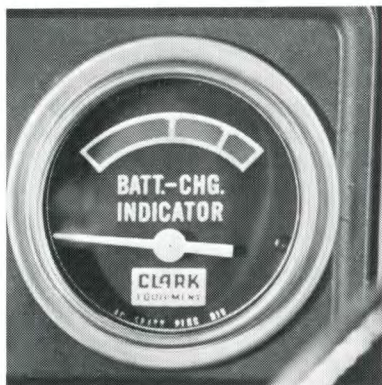

19516

Discharge Indicator

The battery discharge indicator indicates if the battery has sufficient charge. The needle of the discharge indicator should always be on the green scale. While driving watch the indicator frequently in order to inform yourself about the state of the battery charge.



19517

Hour Meter

On switching-on, whereby the key in the lock is turned clock-wise, the hour meter is started. We recommend that the required maintenance work is carried out in accordance with the indicated lapsed hours.

NOTE

On customers request the truck may be equipped with a warning device against overheating of the drive motors and to much wear of the carbon brushes.

Two diodes are located above of the hour meter. In case of excessive temperature or to much wear one of the diodes will burn.

Know Your Fork-Lift Truck



19515

Brake Pedal

With this brake pedal the hydraulic disc brake is actuated.

Parking Brake Lever

The parking brake may be adjusted in the manner shown in the photograph. In order to prevent any damage to the brake great care is required. Adjustment should therefore be carried out by a competent mechanic only.

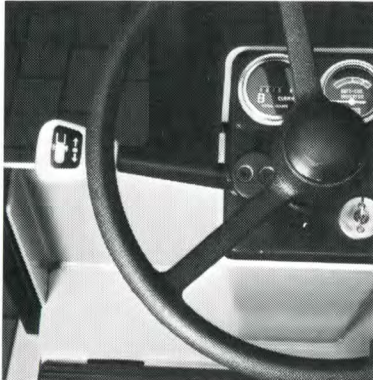

24669

Driving Direction Lever

With the driving direction lever, you can select the desired direction of moving. Furthermore, you can stop the truck by moving the driving direction lever into the opposite direction of moving. You can thereby switch to reverse direction – e.g. during forward motion and with down treaded accelerator pedal. The forklift truck is now braked by counter-current. You can influence braking action by the accelerator pedal.

**Familiarise
yourself with the controls
and follow
the safety regulations!**

Know Your Fork-Lift Truck

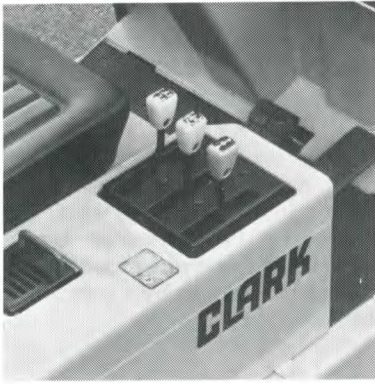

24670

Hydraulic Control Lever

By means of the levers on control valve the lift and tilt cylinders are operated. The handles of the levers carry symbols, indicating their respective function.



24671

With the tilt control lever, you are able to control the inclination direction of the upright. When the lever is pulled back, the upright also inclines backwards. If the lever is pushed forwards, the upright inclines forwards.

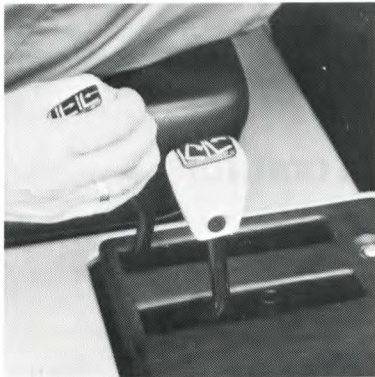

24672

With the lift control lever, you are able to raise and lower the fork carrier. When the lift control lever is pulled back beyond a specific point, a micro switch is closed, and the hydraulic motor runs at maximum rotational speed. A load is powerfully and quickly lifted.

Know Your Fork-Lift Truck



24673

When the lift control lever is pushed forwards, the fork carrier is lowered. Through strong or weak pushing-forwards, you determine the lowering speed. During lowering operation the hydraulic motor will not run.



24674

Steering

The steering wheel is connected with a hydrostatic steering gear. From the hydraulic pump motor, oil flows at high pressure to this steering gear, and therefore steering could not be easier. Never operate a fork-lift truck on which you notice a steering system fault.

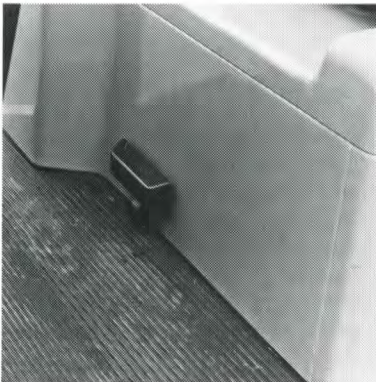

24675

Battery

For lifting out or maintenance of battery the battery cover can be swivelled upwards. For this purpose push the locking lever upwards.

Know Your Fork-Lift Truck

CLARK EQUIPMENT		CLARKLIFT		
TRADE MARK OF CLARK EQUIPMENT CO. U.S.A. MFG. UNDER LICENSE BY CLARK EQUIPMENT GMBH 433 MÜLHEIM/RUHR WESELER STR. 48-50 GERMANY				
MODEL NO.	<input type="text"/>	TYPE	<input type="text"/>	
SERIAL NO.	<input type="text"/>	<input type="text"/>	<input type="text"/>	
ATTACHMENTS	<input type="text"/>			
	CAPACITY WITH ATTACH LISTED ABOVE OR WITH FORKS - UPRIGHTS VERTICAL			
	KG	A	B	C
	<input type="text"/>	<input type="text"/>	<input type="text"/>	<input type="text"/>
	<input type="text"/>	<input type="text"/>	<input type="text"/>	<input type="text"/>
APPROX. WT. ALL TRUCKS	LESS BATT. - ELECTRICS		<input type="text"/>	
APPROX. WT. ELECTRICS ONLY	WITH MAX. BATT. WT.		<input type="text"/>	
BATTERY WT.	MAX	MIN	<input type="text"/>	
BATTERY	AH	NO.	<input type="text"/>	
CAPACITY	KG	VOLTS	<input type="text"/>	
FOR OTHER CAPACITIES-CONSULT MANUFACTURER				

Data and capacity plate

Know the location of your truck's . . .

- Model number**
- Truck type.** The code letter(s) signifies type of the protection construction. Check with proper authority before entering areas where inflammable or explosive material may be present.
- Serial number**
- Attachment description** (If any).
- Capacity.** Capacity, load center, and lifting height data are stamped in these areas. Do not exceed the maximum specified.
Important: If the truck is modified so as to affect capacity; or, the plate damaged or defaced, get a new plate from your Clark Distributor.
- Truck weight less load.**

Before Starting

**Ensure
operational
safety**

At the beginning of every working day, you should be sure of the operationally safe condition of your fork-lift truck. We recommend you to make the necessary checks with the aid of the Lubrication and Maintenance Chart and the individual points of the section "Before Starting" (UVV 23.0 § 22 (1)).



Walk around your fork-lift truck and take note of obvious damage and untightnesses.

24676



Check whether the fork locking mechanism correctly engages and whether unintentional shifting of the forks is prevented.

17795

Before Starting



17796

The height differences of both fork tips may be max. 6 mm. The fork blade may not be ground down by more than 10%, and the forks may not be distorted.

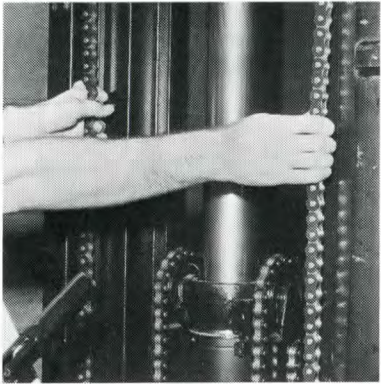

24678

The chains must be uniformly tensioned.



24679

On safety grounds, check the horn function, and, where available, you must also check the rear, braking, and warning lights.

Before Starting



21325

Check the condition of the drive wheels, steering axle wheels, tyres, firm seating of the wheel nuts, and, if your fork-lift truck has pneumatic tyres, the air pressure of the tyres.

Tyre pressure

Drive axle wheels	8 bar
Steering axle wheels	
EM 10	9 bar
EM 12	9 bar
EM 15 S	10 bar



24680

Check the condition of the driver protection roof and load protection grille. Make sure that they are securely tightened.



21326

Check by foot pressure on the brake pedal whether solid resistance can be felt. The pedal may not spring or give way. If this is the case, the forklift truck may not be taken into operation under any circumstances. You should also have the brake immediately repaired. Non-gripping pedal covers must also be renewed.

Before Starting

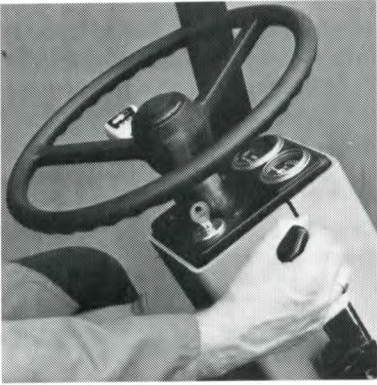

24681

Check proper operation of the parking brake. In its pulled-on state the brake should hold a forklift truck with its permissible load on an incline of 15 %.

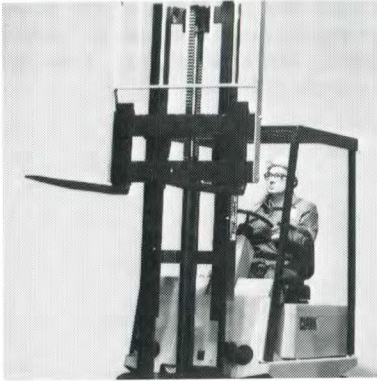

21346

Check the function of the hydraulic installation with the hydraulic pump motor running. All movements of the lifting frame and fork carrier must be soft and smooth ... without jamming. Incline the lifting frame as far as the stop forwards and backwards. Run the fork carrier up to full height. If the max. possible height is not reached, this indicates inadequate hydraulic oil level.



Do not use any fork-lift truck that is not in an operationally safe condition. Fork-lift trucks may only be repaired by authorised persons.

Operating Hints



21322

During your work, observe all functions of your fork-lift truck so that you immediately recognize irregularities and are able to have them rectified without delay.



21329

21329

Make sure that the roadway is clear in the required direction of motion and then press with increasing pressure the accelerator pedal until the fork-lift truck starts to move and the required speed of motion is attained.

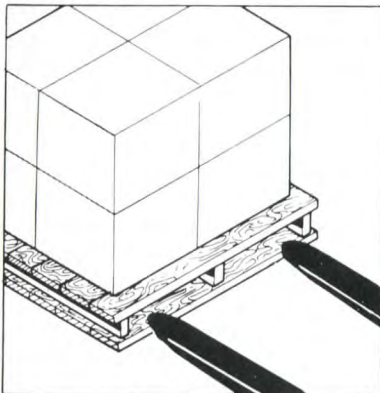

13203

When picking up the load, you must ensure that you pick it up centrally. The forks must be spread as far as possible.

Operating Hints



10759

Raise the fork lock into the vertical position to shift the forks. Ensure that, after shifting, the locking bolt is correctly re-engaged in a groove.

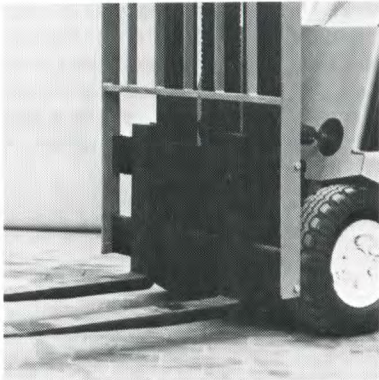

19543

When driving, raise the forks slightly — around 10 cm above floor level — and incline the lifting frame slightly backwards.



14013

When the ignition lock is switched on, the operating hour counter runs, and the needle of the battery charging indicator indicates the charging condition of the battery. Ensure that the needle is always located in the green field during operation.

You can also check the charging condition of the battery by inclining back the lifting frame as far as the stop. The hydraulic system now operates at maximum allowable pressure. For an adequately charged battery, the needle of the battery charging indicator also remains in the green field at this loading.

Maintenance

Maintenance and care are major prerequisites for the operational availability of your fork-lift truck. On these grounds, you should take special note of this section of the operating instructions.

Operating conditions

Time intervals between maintenances are largely determined by operating conditions. It is not difficult to understand that operation in sandy, dusty locations requires shorter maintenance intervals than operation in clean storage halls. The indicated intervals are intended for normal operation. To allow better understanding of this aspect, the following clarification should be made:

NORMAL OPERATION:

Basically, eight-hour material handling, mostly in buildings or in the open air.

SEVERE OPERATION:

Prolonged operating hours or permanent application.

EXTREME OPERATION:

1. In sandy or dusty locations, i.e. cement works, sawmills, briquetting or stone pulverization plants.
2. High-temperature locations, i.e. steelworks, foundries, etc.
3. Sudden temperature changes (constant trips from buildings into the open air), e.g. cold stores, etc.

If your fork-lift truck is used in extreme operating conditions, you must shorten the maintenance intervals accordingly.

Electric motors

The time interval for maintenance operations is chiefly determined by carbon brush service life, unless any aggravating operating conditions (e.g. elevated dust loading, dirt) occur.

Under normal motor loading and trouble-free collector and brush condition, a brush life of around 1000 operating hours may be expected.

Under higher loadings or also when the collector is not in proper condition, life may be appreciably shorter.

Maintenance operations should therefore be performed at least every 500 operating hours.

The maintenance intervals may be shortened or lengthened according to experiences gained.

CAUTION

Before any operations on electric motors, always disconnect the battery.

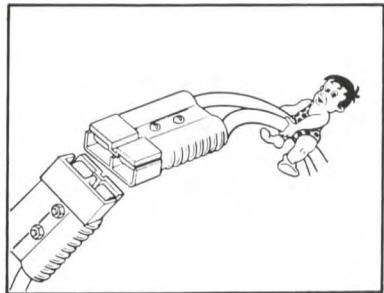

17590

Maintenance

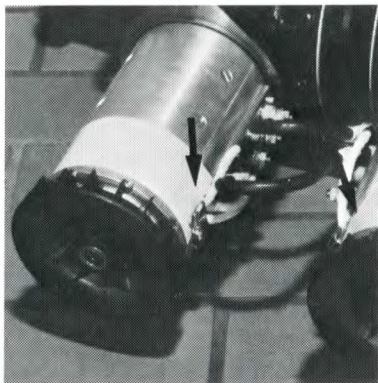

Drive motor

The carbon brushes of the drive motor are located under the cover.

24682

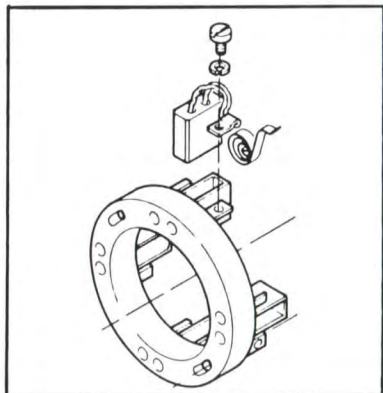

24695

**Ensure
operational
safety**

The mounting screw of the cords should only be loosened to renew the carbon brushes. Check, however, whether the screw is still securely tightened.

Renew the carbon brushes when they are only half as long as the new carbon brushes. The carbon brushes must be changed not later than at a length of 16 mm. In this case the surface of the carbon brush is located 4 mm below of the holder surface. The carbon brushes must also be renewed if the two brushes in one holder are differently worn. Broken carbon brushes and those with loose cords must also be renewed.

Check whether the carbon brushes move easily in their guides and whether the application pressure of the springs is within the tolerance range.

All carbon brushes must be simultaneously renewed.

At one maintenance, remove all carbon brush holders to ensure that all carbon brushes are in trouble-free condition. New carbon brushes must be matched to the collector with emery cloth.

Maintenance

Cleaning

Clean heavily contaminated brush holders and collectors with a clean, flux-free, petrol-moistened cloth. Blow out the interior of the motor with compressed air (max. pressure 2 bar). Remove dirt from the cooling air openings. Take care and do not thereby damage the windings. Do not use any liquid solvents, since these could entrain electrically conductive dirt particles deeply into the winding body.

General visual check; replacement of damaged components

Straighten or replace bruised sealing tapes.

Check fan rotors and terminal boards for damage (cracks, fractures, broken fan blades). Damaged fans (imbalance, reduced fan output) and terminal boards must be replaced.

Check field and armature windings for signs of overloading (overheating): darkly discoloured, brittle, or burnt insulations, unsoldered collectors or connecting bolts.

Motors with such overloading damage are unusable.

If, during cleaning, oil or grease has been found in the motor (mostly an oil paste, oil vapour, thickened oil with dust and carbon scour), the cause of oiling is to be sought and eliminated at once (e. g. untight radial sealing rings, leakage oil from the hydraulic installation, etc.).

Important hint:

Rapid carbon brush and collector wear is in most cases attributable to oil effect. The oil (also grease) burns in the brush fire and leaves a sharp-edged oil ash having an emery effect. The brushes may thereby become

inadmissibly worn ahead of maintenance schedule.

Collector

Collectors are in proper condition if the running surface is darkly burnished to high gloss. Through projecting laminations or overhanging insulating webs, the brush running edges break off.

Incisions, notches, scores, and grooves call for basic overhaul of the motor. On no account may the collector be worked with emery paper, emery stones, or a file. The maximum allowable circular running deviation is 0.05 mm.

Collectors may not be finish-turned with arbitrary frequency. A specific minimum diameter may not be short-fallen. If wear has started, this will rapidly increase. The collector should therefore be finish-turned not later than after every 3rd carbon brush set.

In this case, only a little material must be removed by turning to restore a clean running surface. The collector may be frequently finish-turned through minor chip removal.

If deep wear traces are available, a great deal of material needs to be removed, and service life is shortened.

Bearings

The bearings are provided with a cover on both sides and filled with a high-temperature resistant grease. This grease filling is normally sufficient for the entire service life of the bearing and must not be renewed. At basic overhaul of the motor, the bearings should be renewed.

Maintenance

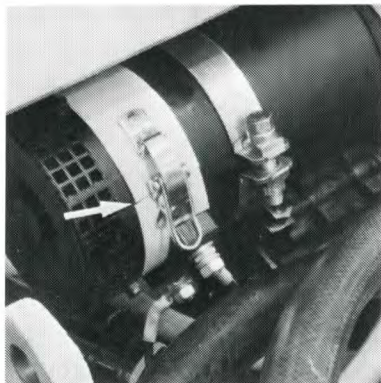

24683

Steering pump motor

The carbon brushes are located under a cover too. It is easy to check the carbon brushes if you dismount the cover.

The carbon brushes should be renewed when they are worn down to 11 mm only.

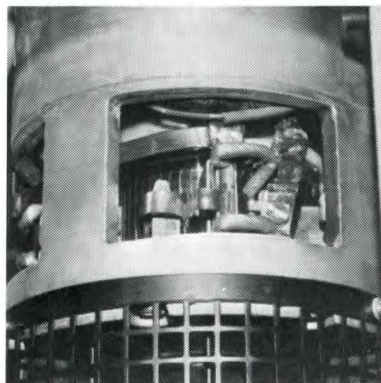

24684

Hydraulic pump motor

The carbon brushes of the hydraulic pump motor should be renewed when they are worn down to 12 mm only. Furthermore the steering- and the hydraulic pump motor should be maintained as drive motors.

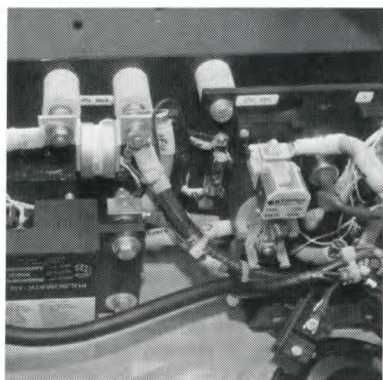

24685

Electronic

Check the electronic panel in accordance to the operating conditions all 50 to 250 hours for obvious damages.

Maintenance

Fuses

To have short cables the fuses are located on different places of the electronic control panel.

If a blown fuse is suspected, this is best checked with an ohmmeter. If a fuse repeatedly blows, a fault may be present.

In this case, it is recommended to have the fork-lift truck checked by the Clark after-sales service.

Remarks: For datas of fuses see page 57.

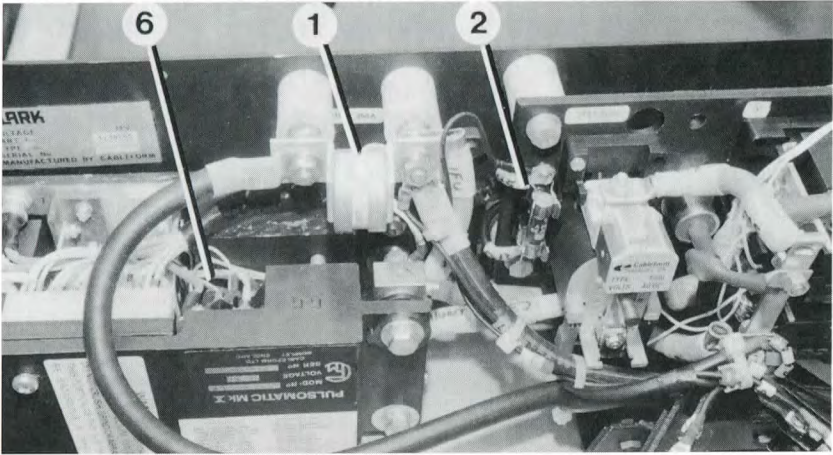

24686

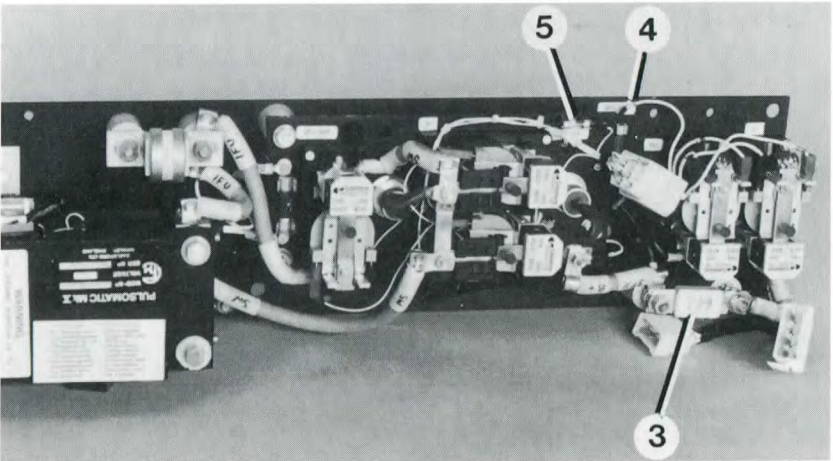

24688

CLARK



Clark semicabins

the ideal and good value protection for the driver

The scope of delivery consists of the frontal frame with safety front screen, PVC sides, roof coverings, a windscreen wiper (12 V for D/LPG and 24 V for electric forklifts) and instructions for fitting.

Consult your Clark dealer about them. He will be pleased to advise you.

Maintenance

Battery

Charging and maintenance of the battery may only be performed by trained personnel in specially provided spaces (see VDE 0510).

Only with automatic chargers can charging of the battery also be performed by the driver himself. Be sure thereby to follow the operating instructions of the charger and the instructions of the battery manufacturer.

General hints

Use only electric lamps to illuminate the battery or charging space. An explosive gas/air mixture occurs during battery operation. Naked flames are therefore prohibited.

Always keep the battery immaculately clean.

Do not place any electrically conductive parts on the cell connectors of the battery.

Avoid smoking, eating, and drinking during maintenance of a battery.

After battery operations, your hands should be thoroughly washed (health damage).

Never separate the battery plug without interrupting the charging process. Switch off the charger beforehand. Fully charge new batteries immediately after delivery. Have damaged cells replaced.

For lifting out of batteries, a special device is to be used (see illustration). Ensure that the chains and safety hooks are checked and have adequate load-carrying capacity. Under no circumstances should you use chains attached to a ring at the centre. These chains pull the trough walls inwards and thereby damage the battery cells.



13107

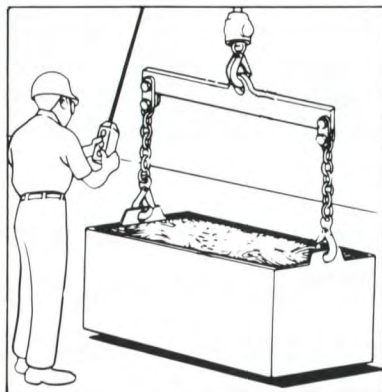

21455

Maintenance

Please note

A modern lead battery (PzS) has an average service life of 1500 discharges. Under normal discharges of 80% of nominal capacity, this corresponds to a time of around five years. Deep discharges of below 80% of nominal capacity appreciably reduce service life. A deep discharge corresponds to around 50 normal discharges. If your fork-lift truck is fully loaded during a shift, you should begin a shift only with fully charged battery to avoid deep discharges.

A battery is fully charged if

- a) the voltage and acid density during charging no longer rise within three hours and three measurements;
- b) all cells evolve gas;
- c) an acid density of 1.26 ± 0.01 at 30°C is available.

A battery is discharged if the acid density has fallen to 1.13 at 30°C . Below this value, deep discharging begins. Owing to the previously

noted limitation of service life, this must be avoided on any account.

To obtain correct values, measurements may not be performed during charging or with loaded battery. A rest time of 15 minutes is necessary so that the density of the acid between the cells and the density of the acid above the cells can be equalized.

Measurement of acid

Measurement of the acid is accomplished with the acidimeter. This consists of a glass body, a rubber ball for drawing up of the acid, and a floating body (densimeter) on whose scale the acid density may be directly read. For measurement purposes and in consideration of the above-noted rest time, acid is drawn from the space above the plates and the density read. It is to be ensured that the densimeter freely floats in the glass body, i.e. it does not stick or impinge against the rubber ball.

**Your CLARK-Dealer
will supply you with chargers
and batteries
of outstanding quality.**

Maintenance

The density of the acid, however, is affected by temperature. When the temperature rises, the volume of the acid increases, and density decreases. If the battery acid has a temperature other than 30°C, you must then convert the measured density to arrive at the value for the reference temperature of 30°C.

Measurement temperature:	Multiply by:
15° C	1.09
20° C	1.06
25° C	1.03
30° C	1.0
35° C	0.97
40° C	0.94
45° C	0.91

Voltage measurement

Voltage measurement by voltmeter is more accurate than acid density measurement. A voltmeter is, however, not everywhere available, and its handling calls for specific expertise.

To check the charging condition, the voltage of an individual cell with unloaded battery is basically measured. The measured voltage is described as rest voltage.

Whereas the standard or nominal voltage comes to 2 V per cell and represents a constant value, rest voltage depends on acid density and the charging condition of the checked cell. The rest voltage is thus the actually available voltage.

Rest voltage may be approximately obtained from acid density as +0.84 or conversely acid density for rest voltages as -0.84. For example, if a rest voltage of 2.10 V is measured, acid density is then $2.10 - 0.84 = 1.26 \text{ g/cm}^3$.

Rest voltage and acid density

Rest voltage	Acid density
2.10 V	1.26 g/cm ³
2.07	1.23 g/cm ³
2.035	1.195 g/cm ³
2.00	1.16 g/cm ³
1.965	1.125 g/cm ³
	normal discharge
1.93	1.09 g/cm ³
	deep discharge

As already noted, a rest pause of 15 minutes is also necessary for rest voltage measurement.

Battery maintenance

Battery service life is quite specifically dependent on thorough maintenance. Your Clark dealer will normally supply you with a battery in filled and charged condition. At delivery, however, you should check whether any transport damage has occurred and whether the cell connectors are properly secured. On Clark batteries, the acid level should be around 25 mm above the synthetic separators. On batteries of other makes, it should accord with the instructions for use of the manufacturer concerned.

To achieve most accurate battery surveillance, you should select a cell at the battery centre and a cell at the trough edge as inspection cells. These cells are permanently observed. The following battery operations are necessary:

Every day: charge, if the battery is fully loaded. Charge at least every 2 to 3 days if the battery is run weakly or to half capacity. In winter, also charge every day when partial discharge occurs.

Maintenance

Every day: measure the **acid density** of both inspection cells to establish battery loading.

Every day: check the acid level in each cell prior to charging. If a level has undergone an especially heavy fall, the cell vessel must be assumed to be cracked or to have a shortcircuit leading to special heating of the cells and thereby to rapid evaporation of the acid water content. The acid level must, as prescribed, be above the splash protection (see indications of battery manufacturer). Ensure, during replenishment of distilled water or purified water, this does not penetrate into the battery troughs.

Once **per week:** check whether all cells uniformly evolve gas and whether, after full charging, the prescribed acid density of 1.26 ± 0.01 at 30°C has been achieved in all cells.

Every month: measure all cells during charging with a voltmeter and establish whether all cells show the same voltage.

Every month, it is absolutely necessary to perform **equalization charging** as per treatment instructions. As previously noted and as indicated in the treatment instructions, it may, however, happen that equalization charging must be performed **more frequently**. This especially applies if the battery has been too deeply discharged or the acid after charging

fails to reach its nominal density. (On this aspect, see indications of the battery manufacturer.) Through application of automatic chargers, equalization charging may be performed through repeated re-engagement after automatic disengagement.

Every month: charging current is to be rechecked once at the beginning of gas evolution and at the end of charging with an ammeter. In the event of excessive values, the mains voltage must also be measured. You should also simultaneously check whether the charging switch responds at attainment of the gas evolution voltage of 2.4 V per cell.

It is also generally recommended to compare from time to time the charger measuring instruments and acidimeter with other best calibrated measuring instruments.

Every month: Check pole screws and cell connectors, which must always be well greased. The pole screws must always be tightened **hand-tight**, since loose pole screws may significantly increase contact resistance and lead to melting of connectors and poles.

N. B.

With regard for optimum service life, you should always ensure that density never falls below a value of 1.13 g/cm^3 . **Under no circumstances may a value of 1.10 g/cm^3 be shortfallen.**

Work Safely
Be Careful

Maintenance

Storage of batteries

If batteries are no longer used for a prolonged period, they are to be well charged prior to disconnection. Self-discharging occurs through leakage currents. It is therefore necessary to recharge the battery every week or to perform maintenance charging at 2.20 to 2.25 V per cell and 40–60 mA per 100 Ah battery capacity.

Equalization charging

During normal chargings, the individual battery cells are not uniformly charged. If you keep a battery maintenance log, this will be apparent from measurement data. To equalize these differences between the individual cells, an additional charging is necessary every month. This may entail inadequate acid density in the cells.

Equalization charging is to be performed until all cells have the same voltage and the same acid density. Equalization charging may be accomplished, e.g. at a weekend, so that charging proceeds for up to three days at max. 2 A/100 Ah nominal capacity.

Tropics

Elevated temperatures accelerate the chemical processes in a battery. The capacity of the battery is thereby not only increased; the plates are also more heavily loaded. To prevent reduction in battery service life as a result of elevated temperature, a thinner sulphuric acid must be used in the tropics. Instead of a sulphuric acid with a density of 1.26 g/cm³, an acid with a density of 1.23 g/cm³ is to be used.

Spare parts may only be ordered from your authorized CLARK dealer. Please quote the type designation and serial number of your fork-lift truck when ordering.

Please also address all technical enquiries to your authorized CLARK dealer; he will be pleased to assist you at all times.

LF04E

Maintenance



21325

Check the condition of the drive wheels, steering axle wheels, tyres, firm seating of the wheel nuts, and, if your fork-lift truck has pneumatic tyres, the air pressure of the tyres.

Tyre pressure

Drive axle wheels	8 bar
Steering axle wheels	
EM 10	9 bar
EM 12	9 bar
EM 15 S	10 bar



24690

Ensure firm seating of the wheel nuts. Tightening torques are as follows:

Drive axle nuts	255–275 Nm
Steering axle nuts	255–275 Nm

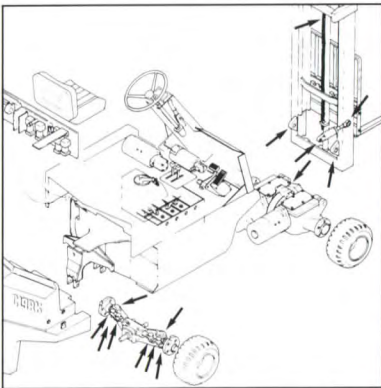

24713

Thoroughly lubricate your fork-lift truck on the basis of Lubrication and Maintenance Chart. Clean the lubricating nipples prior to lubrication and remove emerged grease on the lubrication points after lubrication.

Take this opportunity to lubricate all linkages and joints (shift linkages, etc.) with graphite powder (graphite binds abrasive dirt less than oil or grease).
(see page 55)

Maintenance

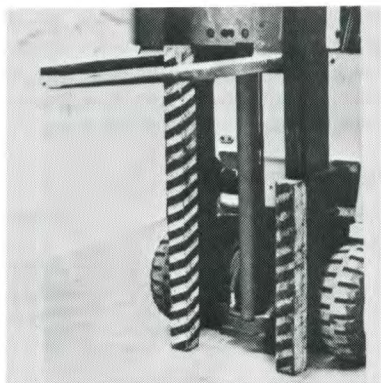

22154

Transmission

To gain easier access to the drive axle, lift the fork carrier around 2m and secure it with adequately stable square timbers.

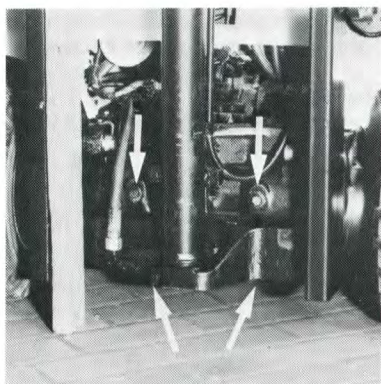

21333

In order to change the oil of the transmission, remove the drain plugs situated on the under side of the housing. After emptying the oil new oil is poured in until it overflows from the check hole. Remember that each transmission half has its own oil.

The transmission oil should be changed after every 2000 hours of operation.

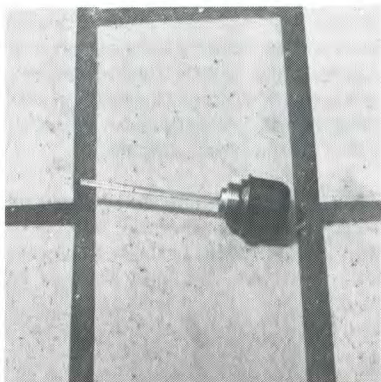

24692

Hydraulic system

Changing the hydraulic oil

The hydraulic oil should be changed after every 2000 hours of operation or at least once a year. On this occasion change the fine filter (25 micron) and clean the filterscreens in the suction lines.

The air change filter which has a wire screen must be cleaned once a year.

The air change filter which has a paper insertion must be renewed once a year.

Maintenance



21330

Draining the hydraulic oil

Caution! So that the oil can be completely emptied, the forklift truck must be level. Lower the fork attachment until the forks rest on the floor. Now place a sufficiently large but flat container under the hydraulic tank and remove the drain plug.

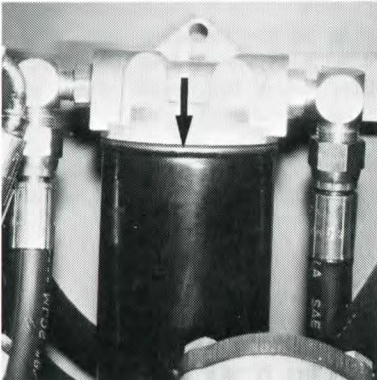

19549

Exchanging the micro filter

The micro filter cannot be cleaned and is only intended for one-time use.

Before inserting the new filter, wet its sealing surface with hydraulic oil and tighten it up by hand.

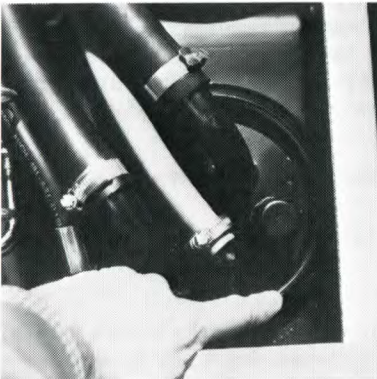

24693

Removal and cleaning oil filter/screens

To remove the screens, disconnect first all hoses from the lid of the hydraulic tank. Ensure that no oil drips onto the pump or drive motor. Loosen the clamping strap and remove the lid of the tank. In order to clean the screens unscrew it from the suction lines. At the same time check that the screens are not damaged.

Maintenance

Refilling with hydraulic oil

After thoroughly cleaning the filter screen and the hydraulic tank, the tank cover can be replaced. When doing this, check the sealing ring for its condition — it should not show any cracks, incisions, or the like — and make sure that you have properly replaced it. After repositioning the drain plug and firmly tightening it up, new hydraulic oil can be run into the filling hole in the tank cover — after unscrewing the gauge stick.

Take care! The oil level may only reach up to the top mark on the gauge stick.

In order to vent the hydraulic system, you should now drive in and drive out the lifting platform

Please note! To check the oil level the dipstick must be screwed in completely to check the correct oil level. Do not set the dipstick on the inlet surface only.

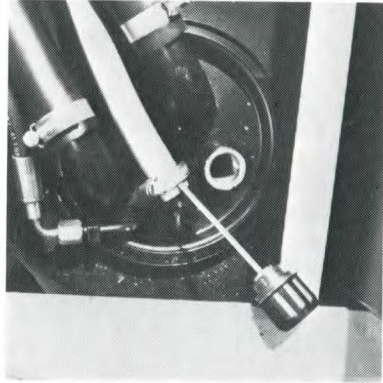

24694

— up to the stops, as well as incline it forwards and backwards. After doing this, again check the hydraulic oil level.

Wheels and tyres

ATTENTION! Too low tyre pressure can impair the stability of your fork-lift truck. So check every day to make sure that the tyres are under the prescribed pressure.

When checking the tyre pressure, examine the wheels and tyres for any obvious damage. Cuts or cracks in the tyre rubber can result in the fabric being damaged by the intrusion of dirt or other foreign matter. So immediately remove dirt and foreign matter. Have wheel repair work carried out without delay, when this is necessary. In no case drive on with damaged tyres!

Check:

1. whether the tyres exhibit cracks or incisions or whether they are damaged in any other way;
2. to make sure that all wheels bolts and nuts are there and are undamaged and tight;
3. whether the rims are damaged.

Mark the damaged areas with chalk and arrange for repair work to be carried out without delay. When exchanging tyres and replacing rims it is imperative that these are of the right size and are of the same quality as those initially supplied.

Maintenance



19552

Changing the drive wheels

In order to change the drive wheels, the fork-lift truck's lifting platform should be raised. Then incline the lifting platform backwards until the stop is reached. Place squared timber and steel plates underneath the lifting platform. Then incline the lifting platform forwards until it is perpendicular. The drive wheels are now exposed and can be removed.

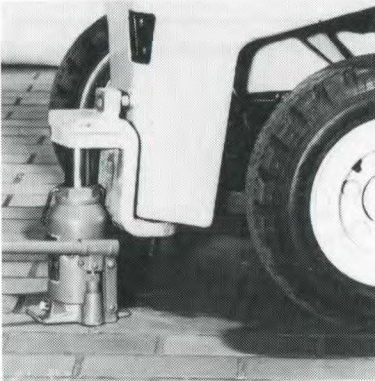

21331

Changes of the steer wheels

To lift the truck a winch or a hydraulic jack is required with a lifting capacity of at least 3000 kp. Before lifting the truck, the wheel bolts should be loosened a little bit. On this model the counterweight is bolted to the truck frame. Therefore the jack can be fitted underneath the counterweight.

If a hydraulic jack — as shown in picture 21331 — is being used, a device is necessary too. This device having part no. 1801093 can be obtained from your local Clark Dealer.



21334

A bolt M 20x50 should be fitted in the lower hole of the device. The hexagon head of the bolt will not allow the counterweight to slip.

Maintenance



When the fork-lift truck is supported in this manner, the above-mentioned device and the lifting appliance can be removed and the steered wheel can be dismantled without danger.

When re-installing the wheel, watch for correct positioning of the valve tube. There is a slot in the wheel hub for locating the valve tube.

21332

This drawing contains all of the dimensions required for the workshop fabrication of the device.

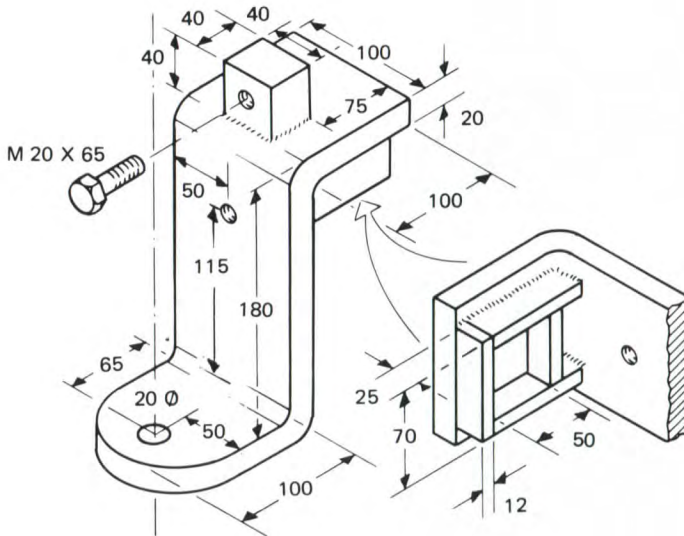

21335

Maintenance

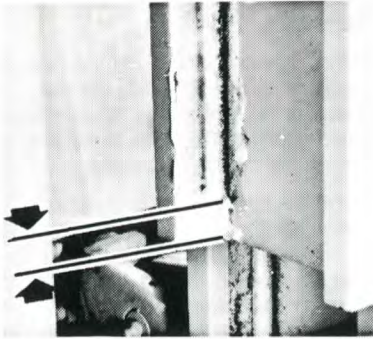

17643

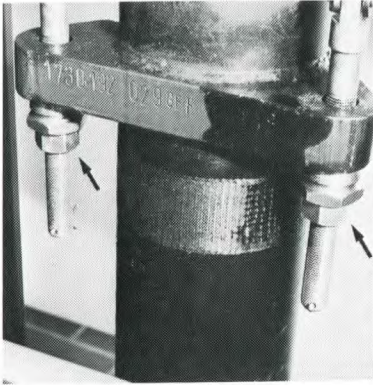

19482

Lifting chain lubrication

Lubrication of the lifting chains forms an important part of maintenance operations. The lifting chains are exposed to heavy loadings and can attain maximum life if they are regularly and adequately lubricated. For this purpose, use CLARK chain lubricant — your CLARK dealer stocks it — which is sprayed on and assures outstanding and adequate lubrication.

Lifting chain adjustment check

The lifting chains are correctly adjusted if the lower fork carrier rollers reach their end position around 13 mm from the lower edge of the inner rail. To be able to check this, proceed as follows: Run out the lifting frame around 1.5 m. Grease the running surfaces in the lower region of the inner rail so that you can recognize distinct running tracks. Run back the lifting frame and pick up a load according to the allowable lifting capacity of your fork-lift truck.

HINT

It is important to perform the lifting chain adjustment check with the nominal load to allow consideration of chain stretching.

Incline the lifting frame slightly backwards and let it down completely. Set down the load and run out the lifting frame again around 1.5 m. You can now see on the basis of the running tracks whether the chains are adjusted as prescribed. Corrections of the setting are to be performed on the upper chain anchors through tightening or loosening of the anchoring nuts.

N. B.

If the chains have stretched by more than 3 % of their original lengths, they must be replaced on safety grounds. For this purpose, confidently contact the after-sales service of your CLARK dealer.

Maintenance



24719

Attention

When removing the counterweight you have to be especially careful. The bracket, on which the drivers overhead guard is mounted, is not placed above the centre of gravity.

If the counterweight is hung on this bracket without a special device, it will tilt during the lifting procedure into a sloping position. This lifting device can be manufactured according to drawing HSO 3775 which can be ordered.

In case of unsatisfactory performance or even a complete breakdown of your forklift truck ensure the following before calling on the services of your local CLARK distributor:

- 1. The battery is fully charged.**
- 2. The battery makes safe and firm connection.**
- 3. There are no foreign objects on the contactor panel.**
- 4. All wires and cables are sound and properly secured.**
- 5. All cable connections and plugs are safe and firmly connected.**

Maintenance

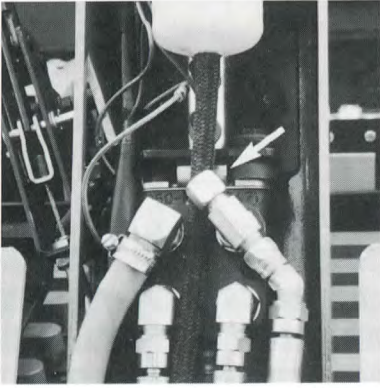

24697

The test point for the steering pressure is located in the steering column on the steering gear inlet port. If you want to check the steering pressure turn the steering axle wheels completely left. In this case the system operates over relief and connected gauge shows the pressure.

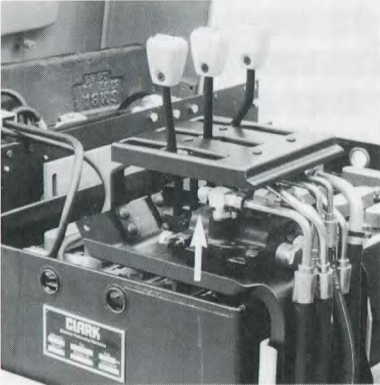

24698

The test point for hydraulic pressure is located on the main hydraulic valve inlet port. Tilt upright back. Hold tilt lever back until the pressure builds up and moves the pressure relief valve into open position. An attached pressure gauge will show relief valve pressure.

NOTE

Avoid holding the tilt lever (or the steering wheels) longer than is necessary to check pressure reading on gauge.

Lubrication and Maintenance Chart

CLARK

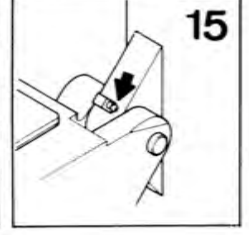
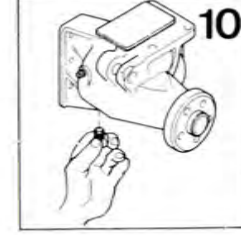
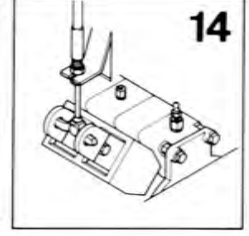
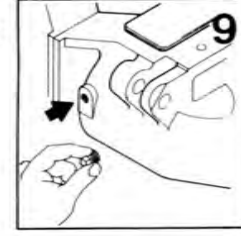
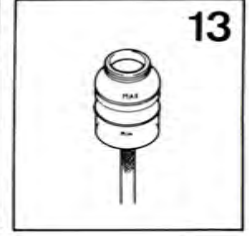
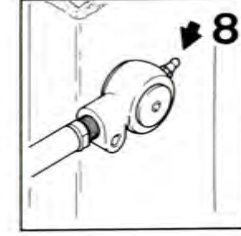
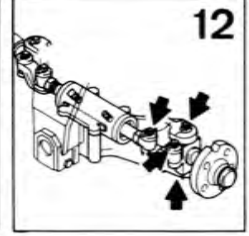
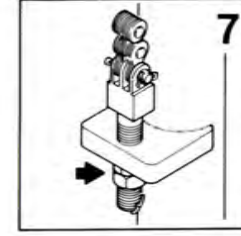
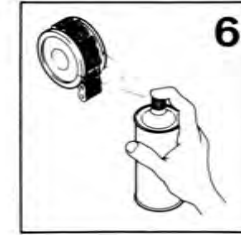
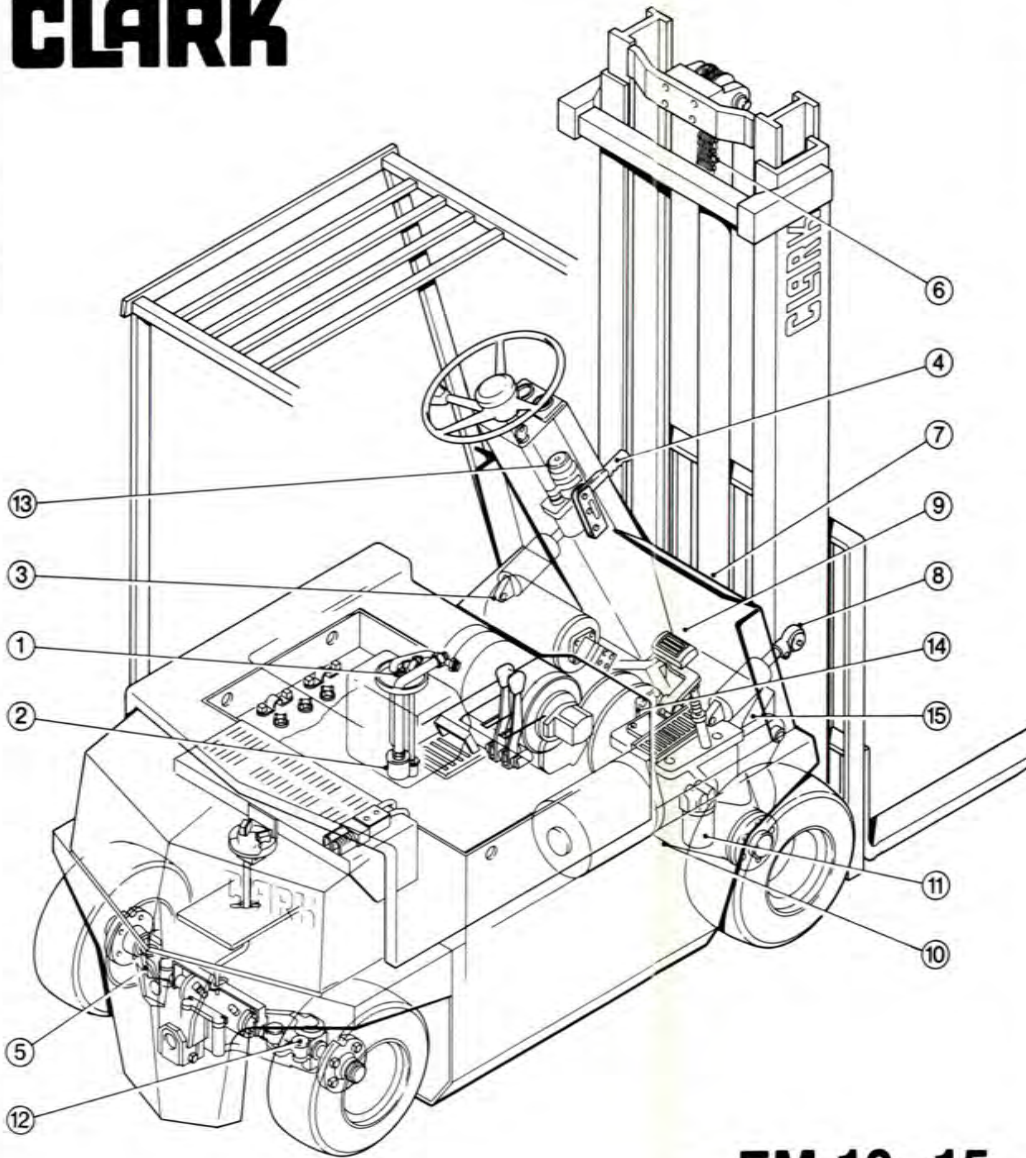
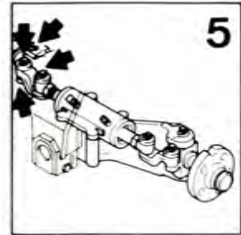
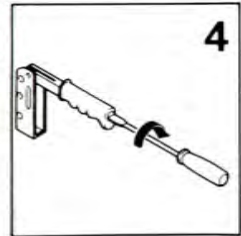
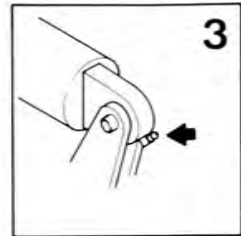
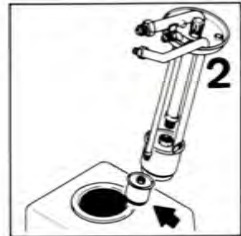
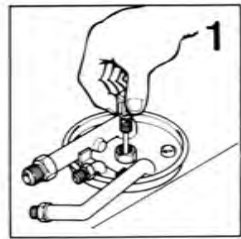

EM 10-15

Lubrication recommendation

H Hydraulic Fluid

according to Clark specification MS-68

e. g.	BP	Energol HLP-D-32 (HD)
	ELF	Acantis 21
	FINA	Hydran 31
	MOBIL	Mobil HLP 32 C
	TEXACO	Hydraulic fluid MS 68
	SHELL	Tellus oil 32
	GULF	Harmony 32 AW
	CHEVRON	EP Hydraulic oil 32

T Transmission Fluid

according to GM-Dexron specification

e. g.	BP	Autran DX Dexron
	MOBIL OIL	ATF 220 Dexron
	FINA	ATF Dexron
	TEXACO	ATF 6673 Dexron

B Brake Fluid

according to specification SAE-J-1703-DOT 3

e. g.	Ate Original DOT 3 Brake fluid S
	IGOL Super Block Fluid

G Multi purpose grease

according to Clark-specification MS-9C & MS-107 C

e. g.	BP	Multi purpose grease L 2
	ELF	Multigrease
	FINA	Morson
	MOBIL	Mobilgrease MP
	TEXACO	Marfak All Purpose
	SHELL	Alvania Grease EP 2
	GULF	Crow Grease EP 2
	CHEVRON	Dura-Lit EP 2

C Chain lube

Clark-chaine lube 886 399

D Dry Lubrication

In accordance with ordinary trade usage like graphit powder

The presence of a brand name on this list indicates its application classification and availability only, and it is not a recommendation of an included product nor condemnation of a nonincluded product.

Specifications

Hydraulic tank capacity:	16 liter
Brake system capacity	1,0 liter
Transmission (each side)	
First fill:	3,9 liter
Oil change:	3,1 liter

Hydraulic system relief valve setting

EM 10	105 bar
EM 12	120 bar
EM 15 S	140 bar

Steering system pressure

EM 10–15 S	70 bar
------------	--------

Tire pressure

Wheels on steer axle – all types	8 bar
wheels on drive axle	
EM 10	9 bar
EM 12	9 bar
EM 15 S	10 bar

Torque Specification for wheel screws

All trucks	255–275 Nm
------------	------------

Torque Specification for counterweight

All trucks	360–400 Nm
------------	------------

Minimum length of brushes

Drive motor:	16 mm
Hydraulic pump motor:	16 mm
Steering pump motor:	11 mm

Fuses:

Main current:	1 FU	350 A
Hydraulic pump motor:	2 FU	275 A
Steering pump motor	3 FU	30 A
Auxiliary equipment	4 FU	15 A
Control current	5 FU	5 A
Electronic	6 FU	3,15 A

Specifications

Specifications	1	Manufacturer	(Abbreviation)	CLARK	
	2	Model	Manufacturer's designation	EM 10	
	3	Load capacity	Q rated load	t	1.0
	4	Load centre	C distance	mm	500
	5	Drive unit	Battery, Diesel, Petrol, L.P. Gas	battery	
	6	Operator type	Stand on/driver seated	driver seated	
	7	Tyre type	C = cushion, P = pneumatic, front / rear	P / P	C / C
	8	Wheels (x = drive wheels)	Number of wheels, front / rear (Dual wheels)	2x / 2	2x / 2
Dimensions	9	Upright (preferred std)	h_3 Standard lift height	mm	3300
	10		h_2 Standard free lift	mm	127
	11		h_5 Full free lift	mm	1609
	12	Fork carriage	DIN 15 173 A/B/no	mm	II-A (ISO)
	13	Fork	s · e · l	40 x 80 x 914	
	14	Tilt of upright	forward α / backward β	degrees	3° / 8°
	15	Overall dimensions	L_2 Length to face of forks	mm	1813
	16		B Width	mm	970
	17		h_1 Height, upright lowered	mm	2107
	18		h_4 Height, upright extended	mm	3800
	19		h_6 Height, overhead guard	mm	1980 / 1977
	20		h_7 Seat height	mm	924 / 921
	21	Turning radius	W_a	mm	1634 / 1616
22	Load centre Distance	x Centre of drive axle to fork face	mm	348	
23	90° stacking aisle	Aisle for pallets 800 x 1200 / 1000 x 1200	mm	2982 / 3182 / 2964 / 3164	
Performance	24	Speeds	Travel laden / unladen (optional)	km/h	12.8 (14.7) / 13.9 (16.0)
	25		Lifting laden / unladen	m/s	0.33 / 0.40
	26		Lowering laden / unladen	m/s	0.40 / 0.40
	27	Drawbar pull	laden / unladen (60 min.)	N	1139 / 1292
	28	Max. drawbar pull	laden / unladen (5 min.)	N	4319 / 4436
	29	Gradeability	laden / unladen (at 2.0 km/h)	%	25.7
	30	Gradeability	laden / unladen (5 min.)	%	12.9 / 18.8
31	Acceleration time	Driving laden / unladen 0-10 m	sec.	5.4 / 4.8	

Specifications

WT	32	Service weight	Including battery (line 46)	kg	2453	
	33	Axle loading	laden front / rear	kg	3016	/ 437
	34		unladen front / rear	kg	1310	/ 1143
Chassis	35		Number front / rear (Dual tyres)		2	/ 2
	36	Tyres	Size front	in or mm	18 x 7-8.14 PR	18 x 6 x 12.12
	37		rear	in or mm	16 x 6-8.10 PR	16 x 5 x 10.5
	38	Wheelbase	y	mm	1200	
	39	Tread	Centreline tyres front / rear	mm	797	/ 806
	40	Ground clearance	Laden m ₁ minimum	mm	79	88
	41		m ₂ middle of wheelbase	mm	100	100
	42	Service brake	mech./hydr./electr./pneum.		hydr. / mech.	
	43	Parking brake	Foot		hand	
Drive Line	44	Battery	Type	lead acid		
	45		Volts / Ampere hrs (capacity at 5 hr rate)	V / Ah	48	/ 300-360 ¹⁾
	46		Weight min. / max.	kg	551	/ 609
	47	Electric Motors	Drive motor, hr rating	kW	2 x 2.7	
	48		Lift motor at 20% ED	kW	5.2	
	49	I.C. Engine	Manufacturer / Type			
	50		Rated output B DIN 70 020	kW		
	51		Rated speed DIN 70 020	rpm		
	52		No. of cylinders / displacement (c. c.)			
	53		Fuel consumption [*kg/h]	l/h		
54	Control	Electric truck	Type / Steps	SCR infinite		
55	Transmission	I.C. truck	Type / Speeds			
56	Clutch	I.C. truck	Type			
	57	Operating pressure	For attachments adjustable	max. bar	105	
	58	Sound level	Average at drivers ear	dB(A)		

¹⁾ With special cells.

Notes:

All shown values are for standard upright.
If the truck is supplied with options or other uprights, values can change.

Specifications

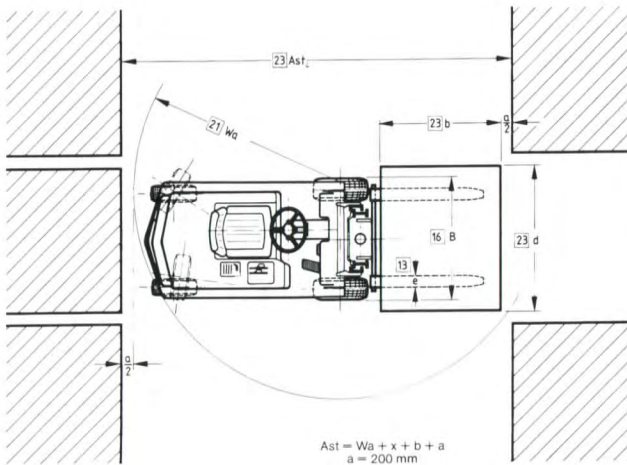
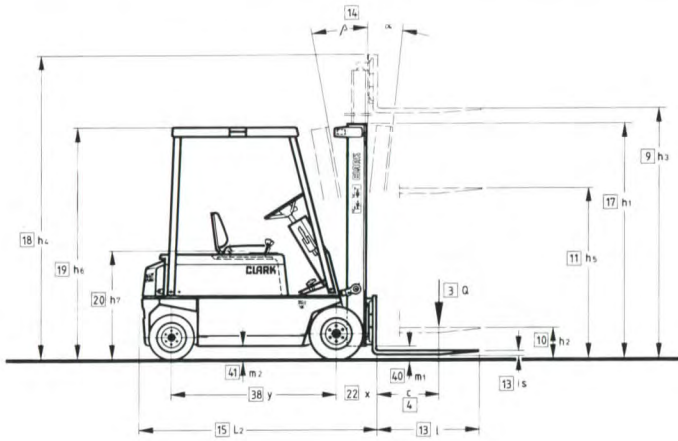

□ For data see corresponding number in chart on inside pages.

Specifications

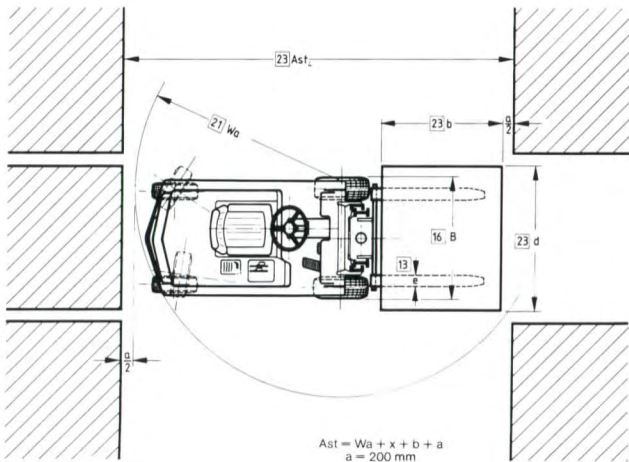
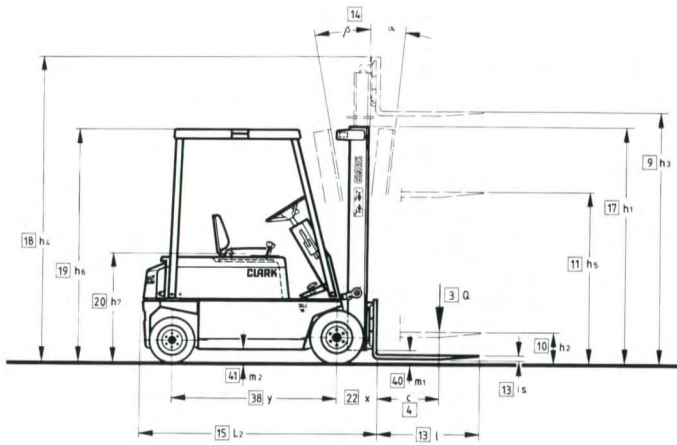

□ For data see corresponding number in chart on inside pages.

Specifications

Specifications	1	Manufacturer	(Abbreviation)	CLARK					
	2	Model	Manufacturer's designation	EM 12					
	3	Load capacity	Q rated load	t	1.25				
	4	Load centre	C distance	mm	500				
	5	Drive unit	Battery, Diesel, Petrol, L.P. Gas	battery					
	6	Operator type	Stand on/driver seated	driver seated					
	7	Tyre type	C = cushion, P = pneumatic, front / rear	P	/	P	C	/	C
	8	Wheels (x = drive wheels)	Number of wheels, front / rear (Dual wheels)	2x	/	2	2x	/	2
Dimensions	9	Upright (preferred std)	h_3 Standard lift height	mm	3300				
	10		h_2 Standard free lift	mm	127				
	11		h_5 Full free lift	mm	1609				
	12	Fork carriage	DIN 15 173 A/B/no	mm	II-A (ISO)				
	13	Fork	s · e · l	40 x 80 x 914					
	14	Tilt of upright	forward α / backward β	degrees	3° / 8°				
	15	Overall dimensions	L_2 Length to face of forks	mm	1923				
	16		B Width	mm	970				
	17		h_1 Height, upright lowered	mm	2107				
	18		h_4 Height, upright extended	mm	3800				
	19		h_6 Height, overhead guard	mm	1980				1977
	20		h_7 Seat height	mm	924				921
	21	Turning radius	W_a	mm	1740				1733
22	Load centre Distance	x Centre of drive axle to fork face	mm	348					
23	90° stacking aisle	Aisle for pallets 800 x 1200 / 1000 x 1200	mm	3088	/	3288	3081	/	3281
Performance	24	Speeds	Travel laden / unladen (optional)	km/h	12.5 (14.4) / 13.7 (15.8)				
	25		Lifting laden / unladen	m/s	0.31 / 0.40				
	26		Lowering laden / unladen	m/s	0.40 / 0.40				
	27	Drawbar pull	laden / unladen (60 min.)	N	1071 / 1266				
	28	Max. drawbar pull	laden / unladen (5 min.)	N	4251 / 4410				
	29	Gradeability	laden / unladen (at 2.0 km/h)	%	22.5				
30	Gradeability	laden / unladen (5 min.)	%	11.3 / 17.5					
31	Acceleration time	Driving laden / unladen 0-10 m	sec.	5.5 / 4.9					

Specifications

WT	32	Service weight	Including battery (line 46)	kg	2601		
	33	Axle loading	laden front / rear	kg	3369	/ 428	
	34		unladen front / rear	kg	1351	/ 1250	
Chassis	35		Number front / rear (Dual tyres)		2	/ 2	
	36	Tyres	Size front	in or mm	18 x 7-8.14 PR	18 x 6 x 12.12	
	37		rear	in or mm	16 x 6-8.10 PR	16 x 5 x 10.5	
	38	Wheelbase	y	mm	1310		
	39	Tread	Centreline tyres front / rear	mm	797	/ 806	818 / 801
	40	Ground clearance	Laden m ₁ minimum	mm	75	87	
	41		m ₂ middle of wheelbase	mm	103	100	
	42	Service brake	mech./hydr./electr./pneum.		hydr. / mech.		
	43	Parking brake	Foot		hand		
Drive Line	44	Battery	Type	lead acid			
	45		Volts / Ampere hrs (capacity at 5 hr rate)	V / Ah	48	/ 400-480 ¹⁾	
	46		Weight min. / max.	kg	693	/ 767	
	47	Electric Motors	Drive motor, hr rating	kW	2 x 2.7		
	48		Lift motor at 20% ED	kW	5.2		
	49	I.C. Engine	Manufacturer / Type				
	50		Rated output B DIN 70 020	kW			
	51		Rated speed DIN 70 020	rpm			
	52		No. of cylinders / displacement (c. c.)				
	53		Fuel consumption [*kg/h]	l/h			
	54	Control	Electric truck	Type / Steps	SCR infinite		
55	Transmission	I.C. truck	Type / Speeds				
56	Clutch	I.C. truck	Type				
57	Operating pressure	For attachments adjustable	max. bar	120			
58	Sound level	Average at drivers ear	dB(A)				

¹⁾ With special cells.

Notes:
All shown values are for standard upright.
If the truck is supplied with options or other uprights, values can change.

Specifications

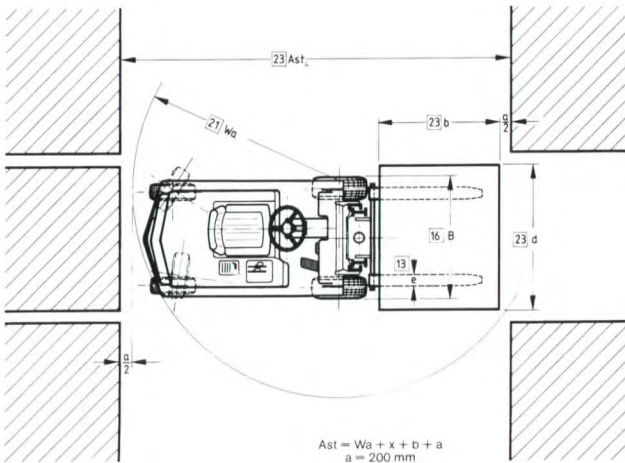
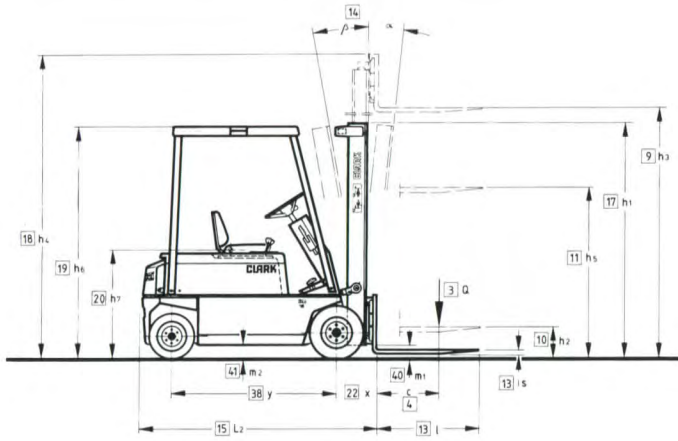

□ For data see corresponding number in chart on inside pages.

Specifications

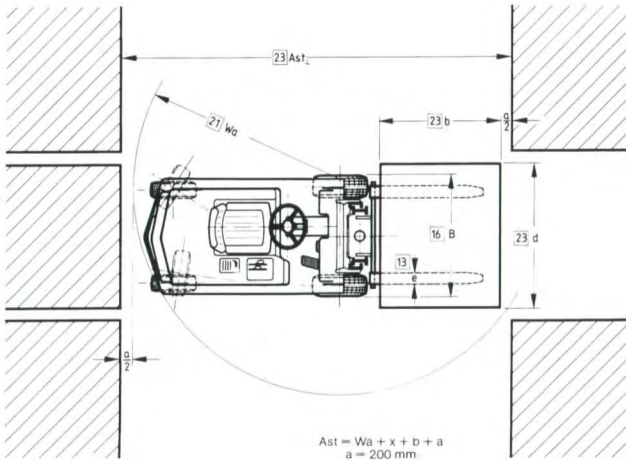
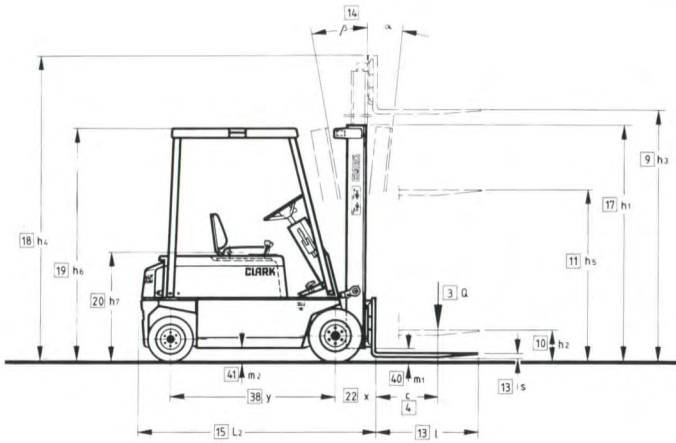

□ For data see corresponding number in chart on inside pages.

Specifications

Specifications	1	Manufacturer	(Abbreviation)		CLARK	
	2	Model	Manufacturer's designation		EM 15 S	
	3	Load capacity	Q rated load	t	1.5	
	4	Load centre	C distance	mm	500	
	5	Drive unit	Battery, Diesel, Petrol, L.P. Gas		battery	
	6	Operator type	Stand on/driver seated		driver seated	
	7	Tyre type	C = cushion, P = pneumatic, front / rear		P / P	C / C
	8	Wheels (x = drive wheels)	Number of wheels, front / rear (Dual wheels)		2x / 2	2x / 2
Dimensions	9	Upright (preferred std)	h_3 Standard lift height	mm	3300	
	10		h_2 Standard free lift	mm	127	
	11		h_5 Full free lift	mm	1609	
	12	Fork carriage	DIN 15 173 A/B/no	mm	II-A (ISO)	
	13	Fork	s · e · l		40 x 80 x 914	
	14	Tilt of upright	forward α / backward β	degrees	3° / 8°	
	15	Overall dimensions	L_2 Length to face of forks	mm	2033	
	16		B Width	mm	1038	970
	17		h_1 Height, upright lowered	mm	2107	
	18		h_4 Height, upright extended	mm	3800	
	19		h_6 Height, overhead guard	mm	1980	1977
	20		h_7 Seat height	mm	924	921
	21	Turning radius	W_a	mm	1855	1850
22	Load centre Distance	x Centre of drive axle to fork face	mm	348		
23	90° stacking aisle	Aisle for pallets 800 x 1200 / 1000 x 1200	mm	3203 / 3403	3198 / 3398	
Performance	24	Speeds	Travel laden / unladen (optional)	km/h	12.2 (14.0) / 13.5 (15.5)	
	25		Lifting laden / unladen	m/s	0.28 / 0.40	
	26		Lowering laden / unladen	m/s	0.40 / 0.40	
	27	Drawbar pull	laden / unladen (60 min.)	N	1009 / 1237	
	28	Max. drawbar pull	laden / unladen (5 min.)	N	4189 / 4381	
	29	Gradeability	laden / unladen (at 2.0 km/h)	%	20.2	
30	Gradeability	laden / unladen (5 min.)	%	10.2 / 16.3		
31	Acceleration time	Driving laden / unladen 0-10 m	sec.	5.6 / 5.0		

Specifications

WT	32	Service weight	Including battery (line 46)	kg	2770			
	33	Axle loading	laden front / rear	kg	3815	/ 455		
	34		unladen front / rear	kg	1420	/ 1350		
Chassis	35	Tyres	Number front / rear (Dual tyres)		2	/ 2		
	36		Size	front	in or mm	18 x 7-8.16 PR	18 x 7 x 12.12	
	37		rear	in or mm	16 x 6-8.10 PR	16 x 5 x 10.5		
	38	Wheelbase	y	mm	1420			
	39	Tread	Centreline tyres front / rear	mm	865	/ 806	792	/ 801
	40	Ground clearance	Laden	m ₁ minimum	mm	73	88	
	41		m ₂ middle of wheelbase	mm	103	100		
	42	Service brake	mech./hydr./electr./pneum.			hydr.	/ mech.	
	43	Parking brake	Foot			hand		
Drive Line	44	Battery	Type		lead acid			
	45		Volts / Ampere hrs (capacity at 5 hr rate)	V / Ah	48	/ 500-600 ¹⁾		
	46		Weight min. / max.	kg	865	/ 955		
	47	Electric Motors	Drive motor, hr rating	kW	2 x 2.7			
	48		Lift motor at 20% ED	kW	5.2			
	49	I.C. Engine	Manufacturer / Type					
	50		Rated output B DIN 70 020	kW				
	51		Rated speed DIN 70 020	rpm				
	52		No. of cylinders / displacement (c. c.)					
	53		Fuel consumption [*kg/h]	l/h				
	54	Control	Electric truck	Type / Steps	SCR infinite			
55	Transmission	I.C. truck	Type / Speeds					
56	Clutch	I.C. truck	Type					
57	Operating pressure	For attachments adjustable	max. bar	140				
58	Sound level	Average at drivers ear	dB(A)					

¹⁾ With special cells.

Notes:

All shown values are for standard upright.
If the truck is supplied with options or other uprights, values can change.

Specifications

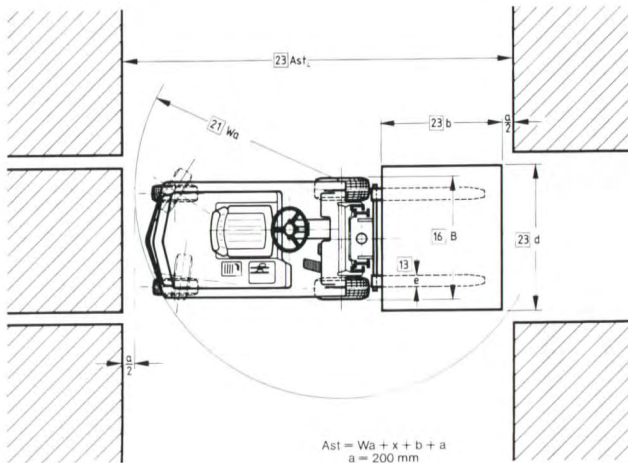
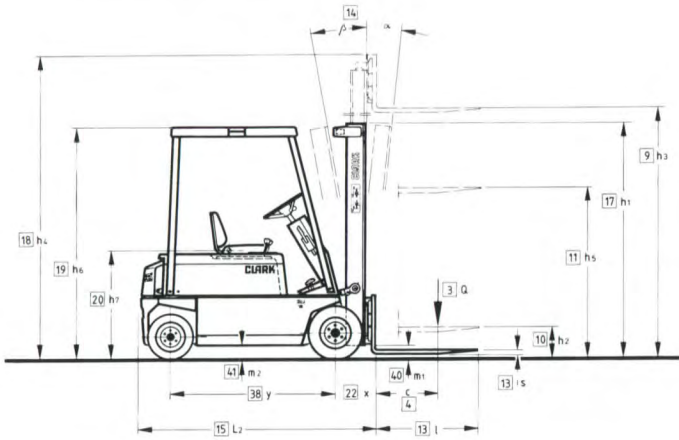

□ For data see corresponding number in chart on inside pages.

Specifications

Upright Table Dimensions in mm Model EM 10-15 S

Clark reference (m)	Lift height h_3	height upright extended h_4^*	height upright lowered h_1	free lift h_2, h_5
---------------------	-------------------	---------------------------------	------------------------------	----------------------

* Without load backrest.



Standard

(2-stage telescopic uprights, Standard free lift)

S 3,00	3000	3500	1960	125
S 3,30	3300	3800	2110	125
S 3,90	3900	4400	2410	125



Hi-Lo

(2-stage telescopic uprights, Full free lift)

H 3,00	3000	3500	1960	1455
H 3,30	3300	3800	2110	1605
H 3,90	3900	4400	2410	1905

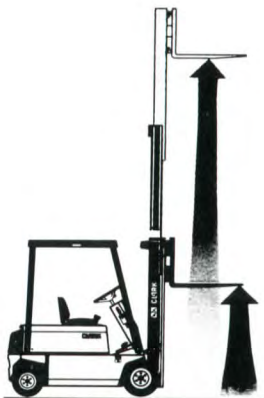

Triplex

(3-stage telescopic uprights, Full free lift)

M 4,11	4110	4610	1885	1380
M 4,34	4340	4840	1960	1455
M 4,80	4800	5300	2110	1605

Specifications

Truck Capacities

The listed capacities are valid only for the upright in vertical position with standard fork carriage and standard forks, up to max. lifting height of 3900 mm.

Load centre is determined from top and front face of forks.

The values are based on a 1000 mm cube load configuration with the centre of gravity at the true centre of the cube. With upright tilted forward lower capacity values are valid.

Attachments, longer forks, exceptional load dimensions and higher lifting heights can reduce the capacity. Please talk to your Clark representative if you require further information.

Specific capacities are shown on truck name plates.

Model EM 10

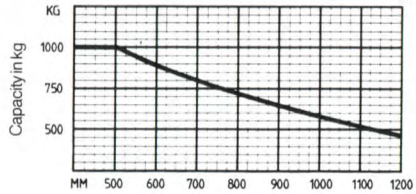

Load centre in mm

Model EM 12

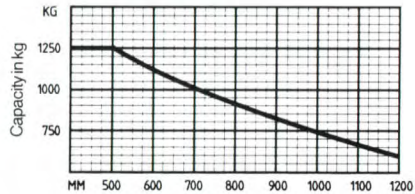

Load centre in mm

Model EM 15 S

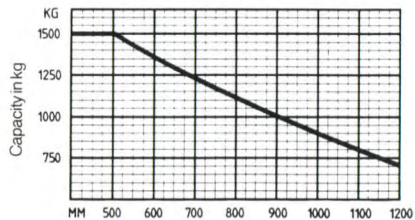

Load centre in mm

Specifications

Battery compartment:

Model	length (mm)	width (mm)	heights (mm)	min. battery- weight (kg)
EM 10	415	830	627	551
EM 12	525	830	627	693
EM 15 S	635	830	627	865

Type of battery connector: Anderson SB 350, grey, with receptacle disconnect.

**Your CLARK-Dealer
will supply you with chargers
and batteries
of outstanding quality.**



Clark Equipment GmbH
Weseler Straße 48-50
D-4330 Mülheim/Ruhr
Tel.: (02 08) 58 50 · Telex: 8 56 684

CLARK

OI-507 GEF E

Your authorized CLARK-Dealer