

---

# Operator's Manual



NP300 20 Through 40  
NS300 30 Through 40

---

**CLARK**

Book No. 2395326  
OM - 538



## **WARNING**

**FOR YOUR SAFETY AND THE SAFETY  
OF OTHERS;**

**BEFORE YOU OPERATE THIS TRUCK!**

**READ ALL WARNINGS AND INSTRUCTIONS IN THE  
OPERATOR'S MANUAL AND ON THE TRUCK.**

**CHECK THE TRUCK FOR CORRECT OPERATION.**

**DO NOT OPERATE THIS TRUCK UNLESS YOU  
ARE TRAINED AND AUTHORIZED TO DO SO.**

# Operator's Manual

**You must be trained and authorized to operate a lift truck**

Follow these rules:  
Read and understand your  
Operator's Manual.



## KNOW YOUR TRUCK.

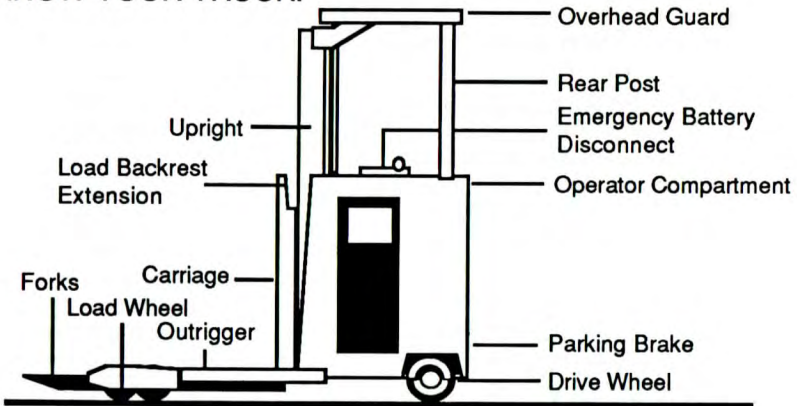

Learn safe operating rules  
and understand the correct  
operation of your truck.



**Breaking these rules will cause serious or  
fatal injury to yourself and others**

# INDEX

chapter	page	chapter	page
<b>1 - OPERATOR MAINTENANCE</b>		Daily inspection - battery connector, key switch, and horn	5.5
Daily inspection	1.1	Daily inspection - instruments	5.6
Safety inspection	1.2	Daily inspection - tilt	5.7
Wheel inspection	1.3	Daily inspection - lift and lower	5.8
Battery inspection	1.4	Daily inspection - pantograph	5.9
Maintenance problems	1.5	Daily inspection - side shift	5.10
<b>2 - GENERAL SAFETY</b>		Daily inspection - forward and reverse travel	5.11
Do's and don'ts	2.1	Daily inspection - plugging and high-speed cut out switch	5.12
Surface and surface capacity	2.2	Daily inspection - review	5.13
No riders	2.3	<b>6 - OPERATION</b>	
Pedestrians	2.4	Before you start	6.1
Operator protection	2.5	Traveling empty	6.2
Travel	2.6	Picking up a load	6.3
Tipover	2.7	Traveling loaded	6.4
Fork safety	2.8	Right angle stacking NP	6.5
Loading docks	2.9	Right angle stacking NS	6.6
Pinch points	2.10	Parking	6.7
Parking	2.11	<b>7 - EMERGENCY TOWING</b>	
<b>3 - OPERATING HAZARDS</b>		Emergency towing	7.1
Operating hazards	3.1	<b>8 - PLANNED MAINTENANCE</b>	
U.L. construction type	3.2	General	8.1
Fast turns and high loads	3.3	Intervals	8.2
Rear swing	3.4	Battery removal	8.3
Pallets and skids	3.5	Handling battery	8.4
Loose loads	3.6	Handling battery	8.5
Long and wide loads	3.7	Handling battery	8.6
Chain slack	3.8	Battery cleaning	8.7
Right-angle stacking	3.9	Battery life, records and installation	8.8
Low overhead clearance	3.10	<b>9 - LUBRICATION</b>	
<b>4 - KNOW YOUR TRUCK</b>		Standard	9.1
Chart	4.1	Location chart	9.2
Capacity, components and features	4.2	Cold storage	9.3
Operators compartment	4.3	<b>10 - TROUBLESHOOTING</b>	
Steering system and control handle	4.4	Troubleshooting	10.1
Brake system, drive axle and electrical components	4.5	Troubleshooting	10.2
Filters, uprights and options	4.6	Troubleshooting	10.3
Name plate	4.7	<b>11 - SCHEMATICS</b>	
Truck decal locations	4.8	NP 300 Electrical	11.1
Safety decals	4.9	NP 300 Hydraulic	11.2
<b>5 - BEFORE OPERATION</b>		NS 300 Electrical	11.3
Drivers's daily check list	5.1	NS 300 Hydraulic	11.4
Daily inspection - wheels	5.2		
Daily inspection - visual	5.3		
Daily inspection - forks	5.4		



## **A Message To CLARK Lift Truck Operators**

Lift trucks are specialized machines with unique operating characteristics designed to perform specific jobs. Their function and operation is not like a car or ordinary truck. They require specific instructions and rules for safe operation.

Safe operation of a lift truck is of primary importance to CLARK. Our experience with lift truck accidents has shown that when accidents happen and people are killed or injured the causes are:

1. OPERATOR NOT PROPERLY TRAINED
2. OPERATOR NOT EXPERIENCED WITH LIFT TRUCK OPERATION
3. BASIC SAFETY RULES NOT FOLLOWED
4. LIFT TRUCK WAS NOT MAINTAINED IN A SAFE OPERATING CONDITION.

For these reasons, CLARK wants you to know about the safe operation and correct maintenance of your lift truck.

This manual is designed to help you learn how to operate your lift truck safely. This manual shows and tells you about operator maintenance and the important general safety rules and hazards of lift truck operation. It describes the special components and features of the truck and their function. The correct operating procedures are shown and explained. Illustrations and important safety messages are included for clear understanding. A section on maintenance and lubrication is included for the lift truck mechanic.

The operator's manual is not a training manual. It is a guide to help authorized operators safely operate their lift truck by illustrating the correct procedures. It cannot cover every possible situation which may result in an accident. You must watch for hazards in your work areas and correct them. It is important that you learn the information in this manual and know your company safety rules! Be sure that your equipment is maintained in a safe condition and do not operate a damaged truck. Practice safe operation every time you use your lift truck. Let's join together to set new standards in safety.

Remember, before you start operating this lift truck, be sure that you understand all driving procedures. It is your responsibility, and it is important to you and your family, to operate your lift truck safely and efficiently. And be aware that the Federal Occupational Safety and Health Act and state laws require that operators be completely trained in the safe operation of lift trucks.

CLARK lift trucks are built to take hard work, but not abuse. They are built to be dependable, but they are only as safe and efficient as the operator and the persons responsible for maintaining them. Do not make any repairs to this truck unless you have been trained in lift truck repair procedures and have been authorized by your employer.

## **TRUCK APPLICATION**

**Each truck is designed for a specific application. Make sure you are using the correct truck for the job.**

### **NARROW AISLE TRUCKS WITH A PANTOGRAPH**

NP trucks are designed to work in warehouses which utilize maximum storage space and minimum aisle space. The NP series with a pantograph features forks which extend and retract, permitting the operator to reach into a rack to deposit or remove a load without having the truck or outriggers enter the rack system.

### **NARROW AISLE TRUCKS WITHOUT A PANTOGRAPH**

NS trucks are designed to work in warehouses which utilize maximum storage space and minimum aisle space. Unlike the NP series, the NS series truck must have clearance below the racks (in a bridged rack system), and between the loads (in a floor load system), for the outrigger and load wheel when the truck is used to deposit or remove loads from the racks, since the outriggers enter into the rack system. Loads wider than the outriggers inside dimension can not be lowered to the floor.

## Operator Maintenance Daily Inspection



At the beginning of each shift, fill out a daily inspection sheet



Do not make repairs yourself. Lift truck mechanics are trained professionals. They know how to make repairs safely.

## Operator Maintenance Safety Inspection

Check safety equipment--  
the overhead  
guard, load  
backrest  
extension, horn,  
and if present,  
backup alarms,  
and rotary  
lights.



Look at the upright.  
BUT KEEP HANDS  
**OUT**

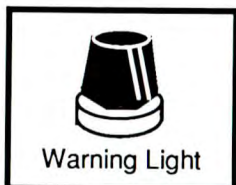
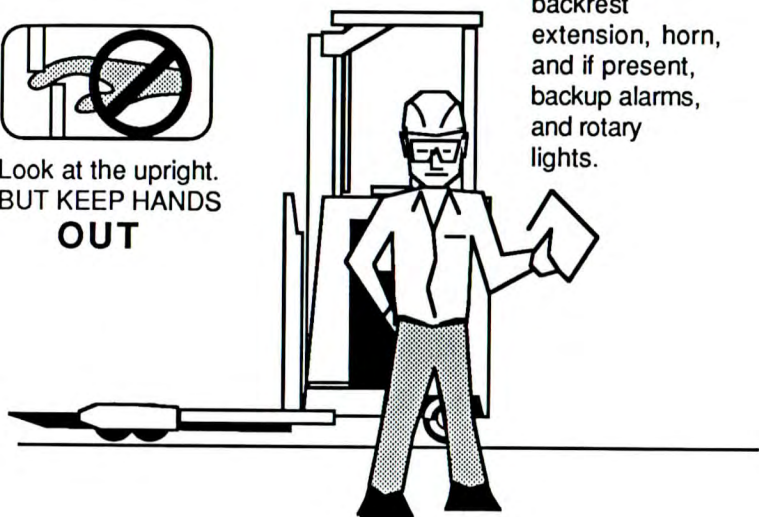

Warning Light



Backup Alarm

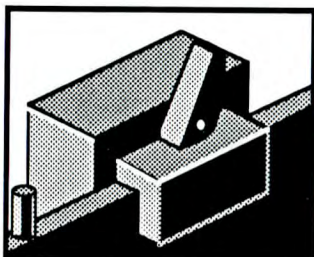

Check fork retainer  
pins and locks.

Other safety devices  
are available from  
your Clark dealer.



# Operator Maintenance

## Wheel Inspection

### LOAD WHEEL

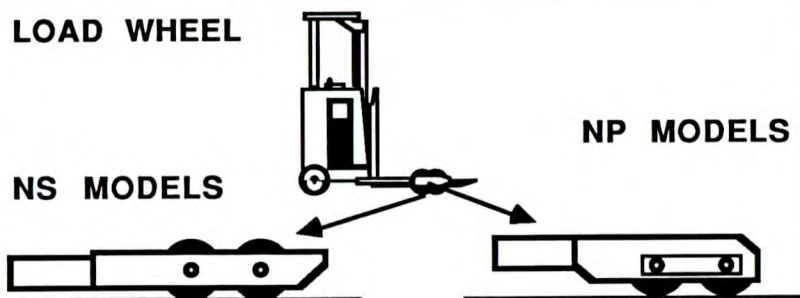

Note any wheel, tire, roller or toe box damage on your checklist.

### DRIVE WHEEL

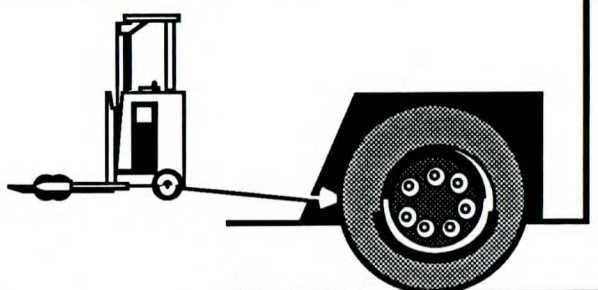

Note any apparent damage on the checklist.

### STABILITY CASTER

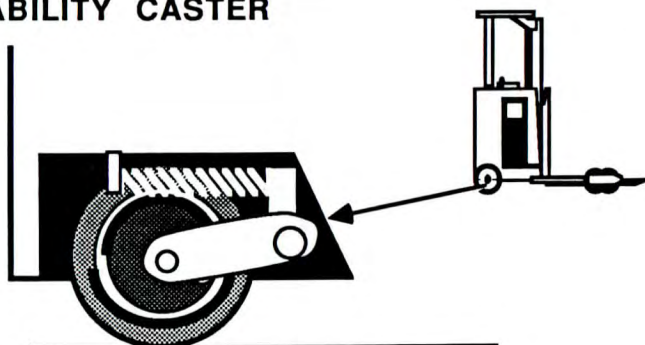

Note any apparent damage on the checklist.



# Operator Maintenance Battery

## Check battery charge

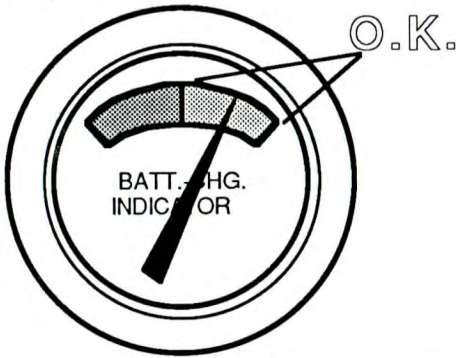

---

## Check Battery Retainment and Emergency Battery Disconnect

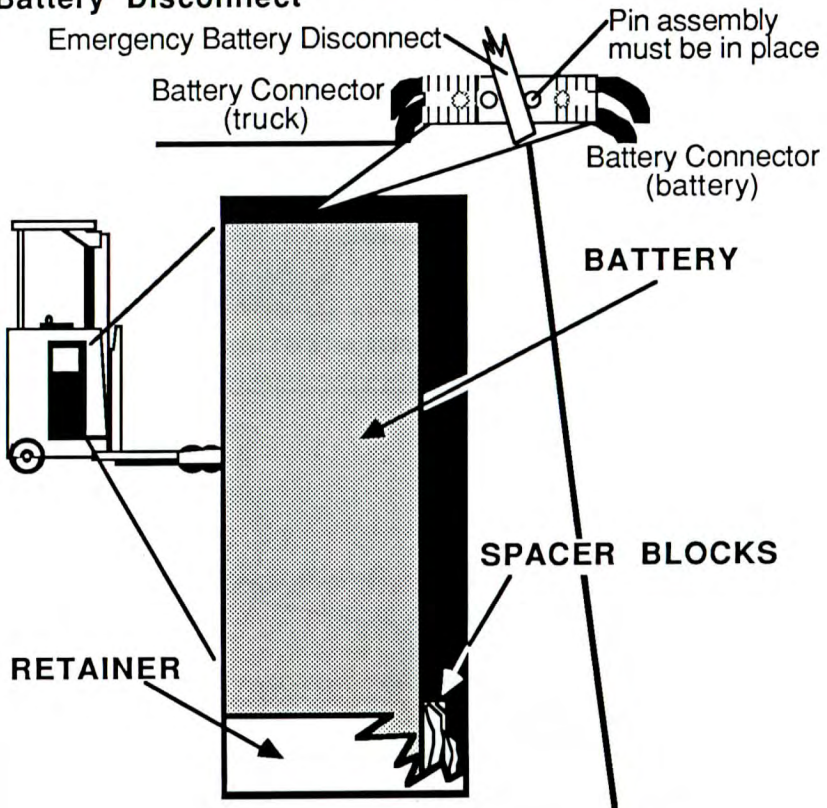

## Operator Maintenance Maintenance Problem

DO NOT OPERATE A LIFT  
TRUCK THAT HAS A  
MAINTENANCE PROBLEM

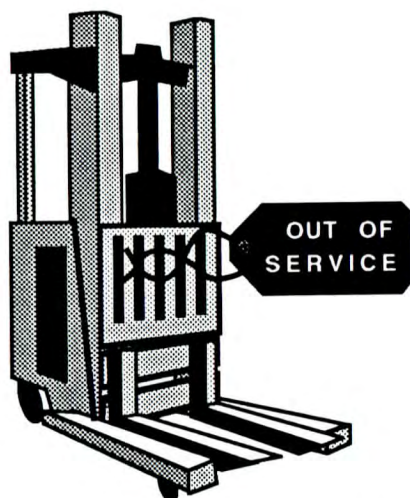

Remove the key and put  
an "out of Service" tag  
on the truck.

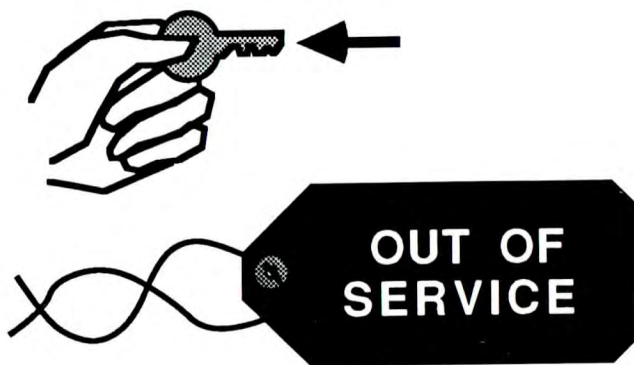



# General Safety Rules

## Do's And Don'ts



DON'T MIX DRUGS AND  
ALCOHOL WITH YOUR JOB.



DO WATCH FOR  
PEDESTRIANS.



DON'T BLOCK SAFETY OR  
EMERGENCY EQUIPMENT



DO WEAR SAFETY  
EQUIPMENT  
WHEN  
REQUIRED



DON'T SMOKE IN  
"NO SMOKING "  
AREAS

## General Safety Rules Surface and Capacity

Avoid or slow down on  
these conditions...

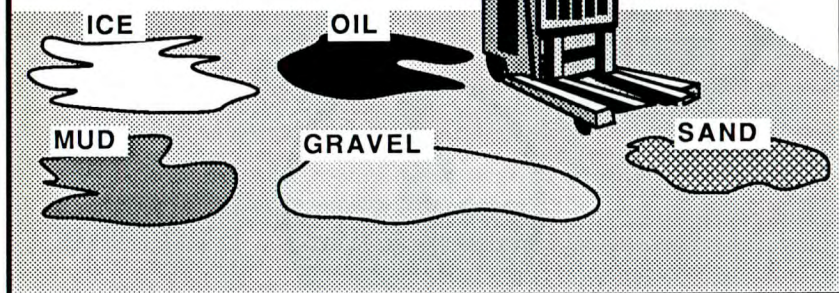

They can cause a truck to tip over.

Know the weight of your truck and load. Check capacities:

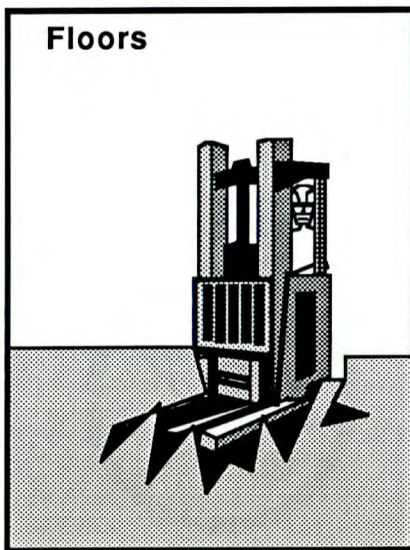



## General Safety Rules

### No Riders

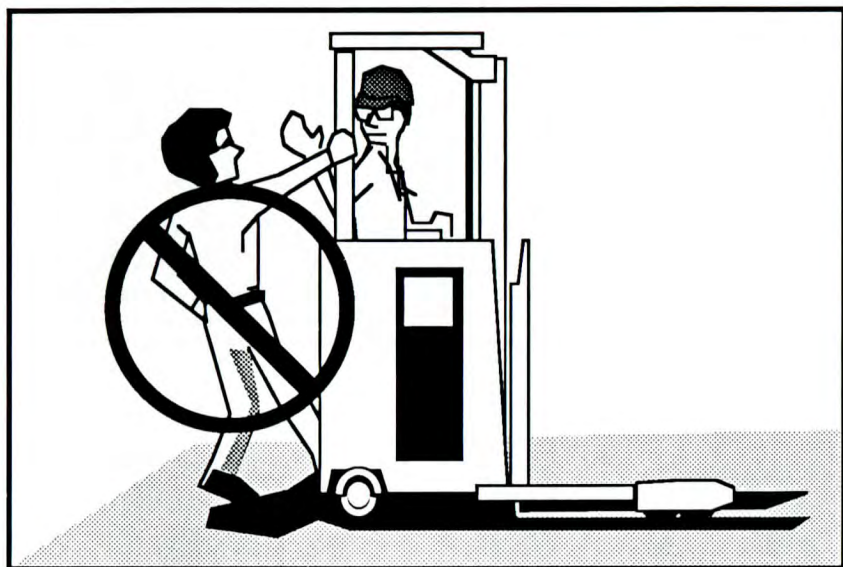

The operator is the only one who should be on a truck.

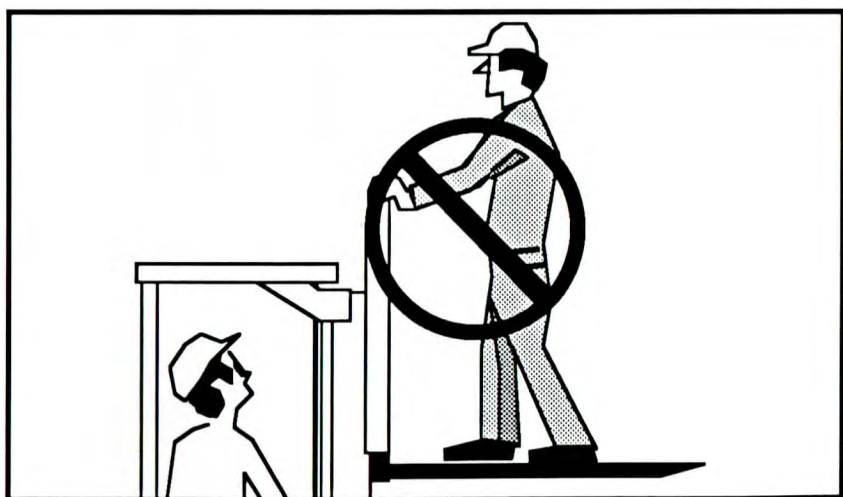

Never transport personnel on the forks of a lift truck.

## General Safety Rules Pedestrians

Watch where you are going, look in the direction of travel. Pedestrians may use the same roadway you do. Sound your horn at all intersections or blind spots.

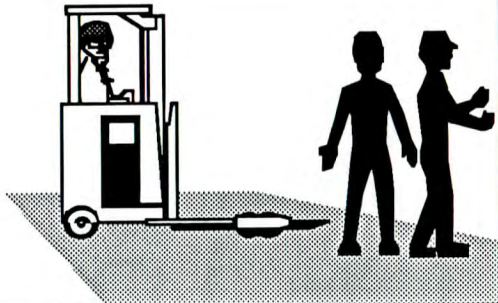

Watch for people in your work area even if your truck has warning lights or alarms. They may not watch for you.

Make people stand back, even when you are parked.

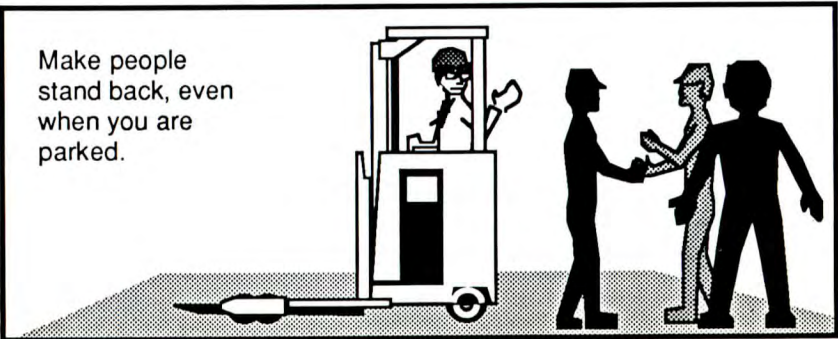

## General Safety Rules Operator Protection

Keep under the  
overhead guard.

Always keep your body  
within the running lines  
of the truck.



Be especially careful when  
traveling in reverse and  
turning. Maneuvering in  
tight areas can be dangerous.

Use the protection  
of the rear posts.  
Watch out for  
intrusion into the operators  
compartment.





## General Safety Rules Travel

Remember that the load should be lowered to a position near the floor (if your truck is equipped with tilt, the carriage should be tilted back to cradle the load) when traveling. If the load blocks your view, travel in reverse.

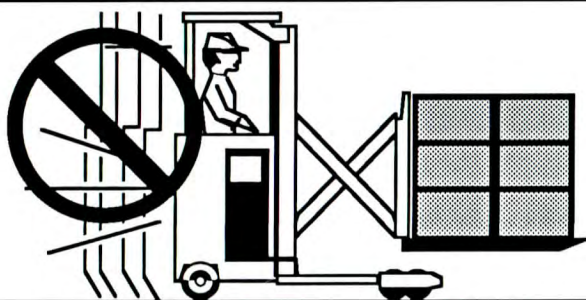
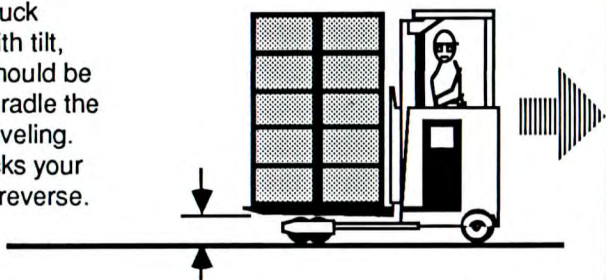

Do not travel with the pantograph extended.

Your truck is equipped with a plugging feature, which means that you need not brake to a complete stop to change directions. Use the directional/speed control to change direction.

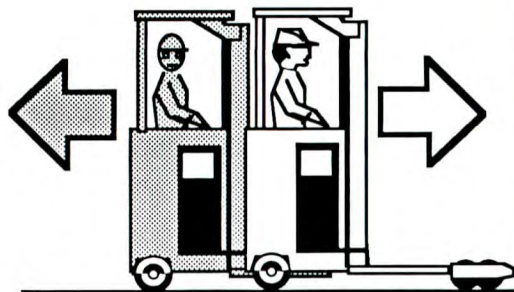

## General Safety Rules Tipover

Truck can tip over if not used properly.

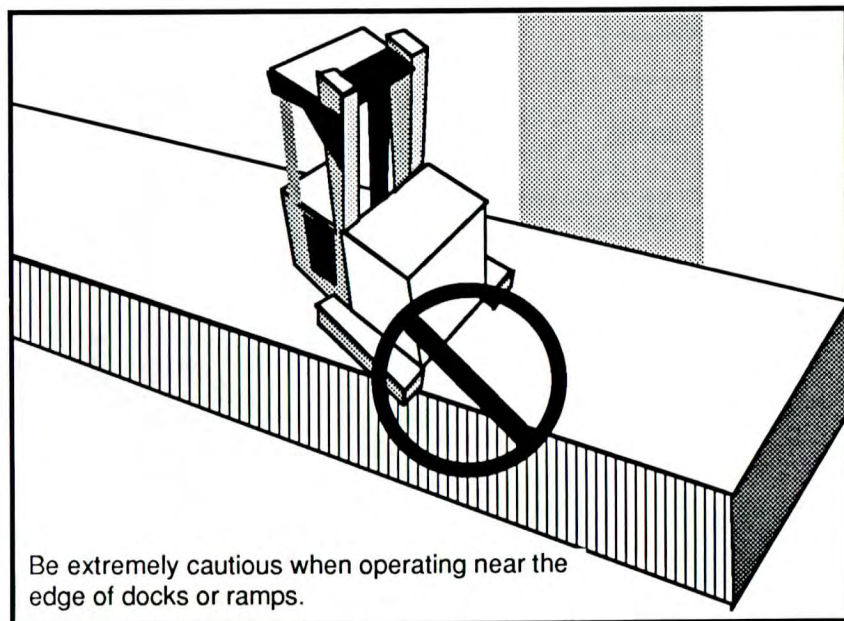
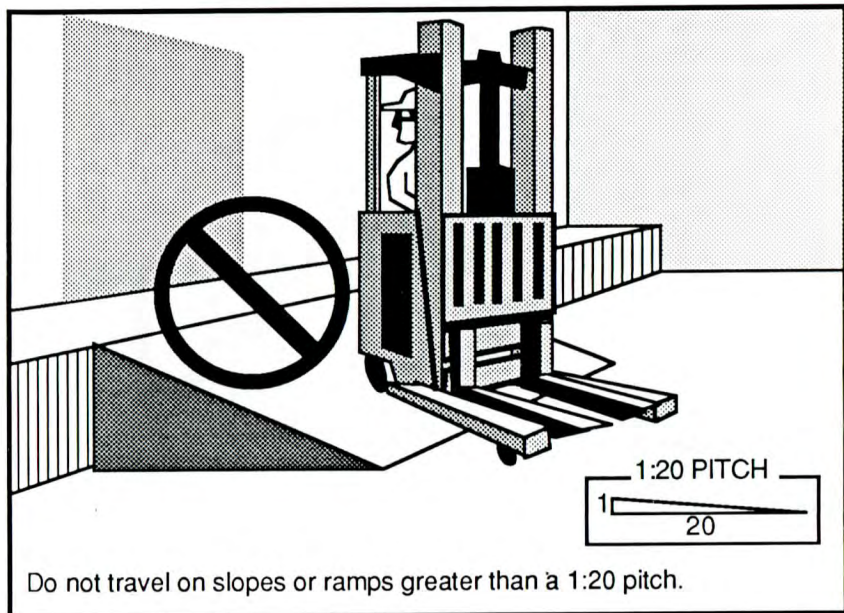



## General Safety Rules Fork Safety

Never allow anyone to walk under raised forks.



There is special equipment to raise people for overhead work.  
**DO NOT USE LIFT TRUCKS.**

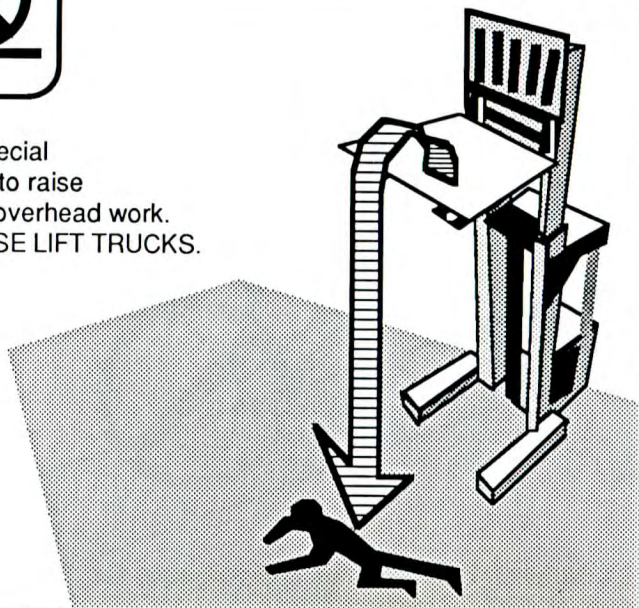

## General Safety Rules Loading Docks

This type of lift truck is NOT intended to load or unload semi-trailers.

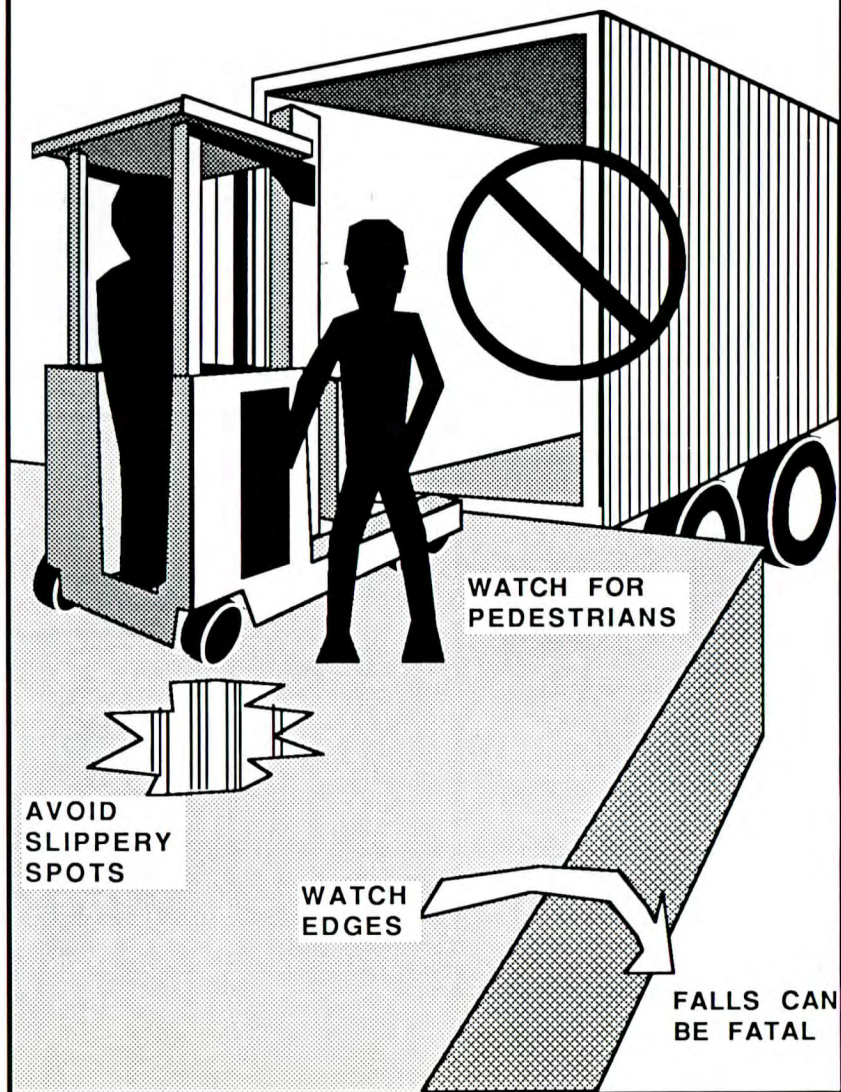

## General Safety Rules Pinch Points

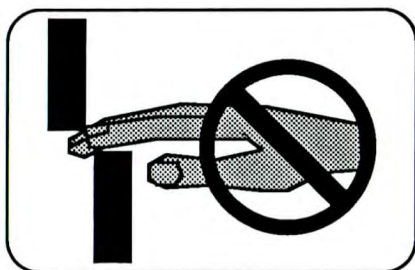

Keep hands, feet  
and legs out of the  
upright.



Don't use the  
upright for a  
ladder.

Never try to repair the  
upright, carriage, chain  
or attachment yourself---

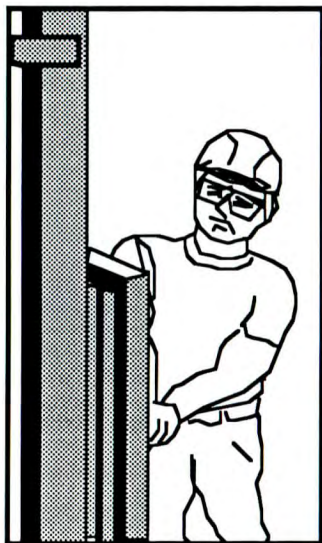

Always get a trained  
mechanic.





## General Safety Rules Parking

Lower forks fully to floor and tilt forward.

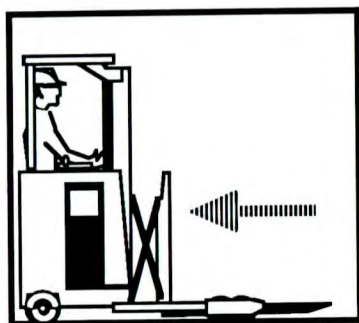
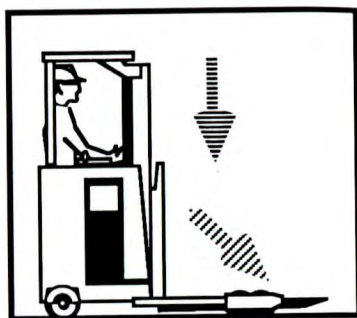

Retract  
pantograph

Be sure travel control is in  
neutral.

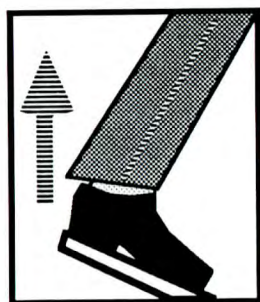
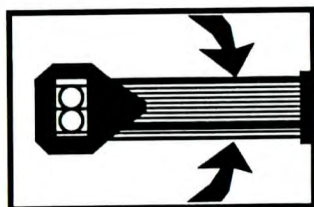

Lift foot  
from brake  
pedal.

Turn key to "off" position.

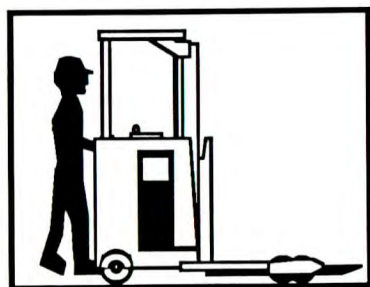

Always come to a complete  
stop before leaving truck.





## Operating Hazards



**This section shows hazards that may cause you, or someone around you, to be killed or badly hurt. As the operator, you must look for other hazards. Get your boss to help you identify and avoid those hazards.**

## Operating Hazards U.L. Construction Type



Know the U.L. construction type of your truck and make certain that trucks of this type may be operated in restricted areas before entering. Never take an unauthorized truck into restricted or hazardous areas. Refer to page 4.8 for location of U.L. construction type.

**AU. 1516**

**CLASSIFIED BY UNDERWRITERS  
LABORATORIES, INC. AS TO FIRE  
AND ELECTRICAL SHOCK HAZARDS  
ONLY. TYPE EE INDUSTRIAL  
TRUCK. SEE UL INDEX OF  
CLASSIFIED PRODUCTS.**

**148800**

**RITERS  
TO FIRE**

**S  
INDUSTRIAL TRUCK. SEE UL  
INDEX OF CLASSIFIED PRODUCTS.**

**149639**

## Operating Hazards Fast Turns and High Loads

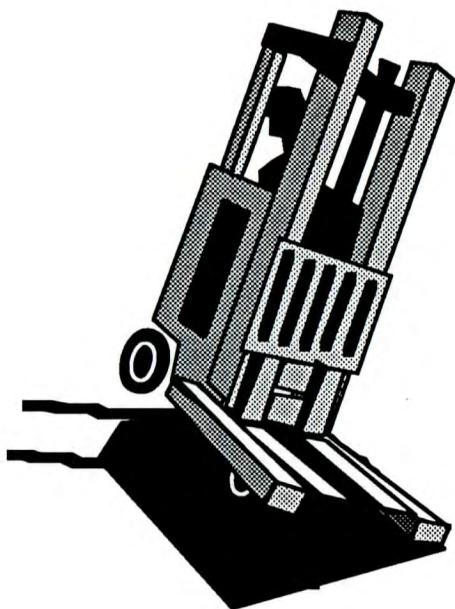

**!** **WARNING:**  
**Fast Turns**

Slow down before turning.  
Truck can tip over.

**!** **WARNING:**  
**High Loads**

Turn too sharp with a raised load and your truck can tip even at slow speeds.

Travel with load raised only when removing or depositing a load.

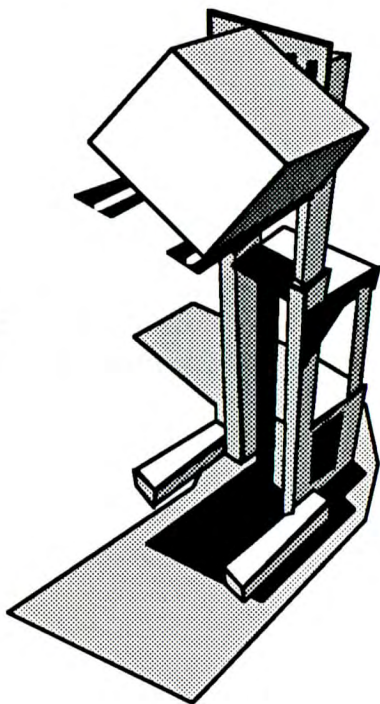

## Operating Hazards Rear Swing

**!** **WARNING:**  
Rear Steering

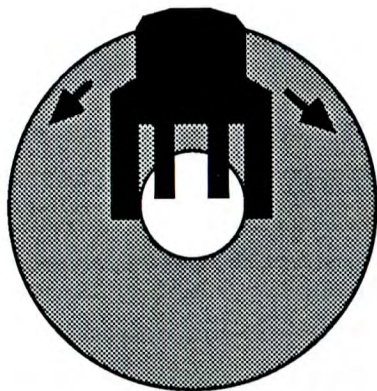

When turning, be sure the rear of the truck does not swing into racks, posts etc.

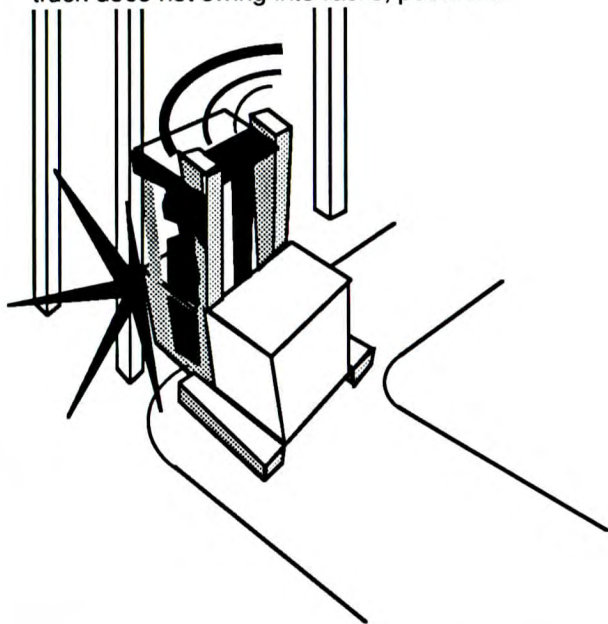



## Operating Hazards Pallets and Skids

 **WARNING:**  
**Poorly maintained and/or  
damaged pallets and skids**

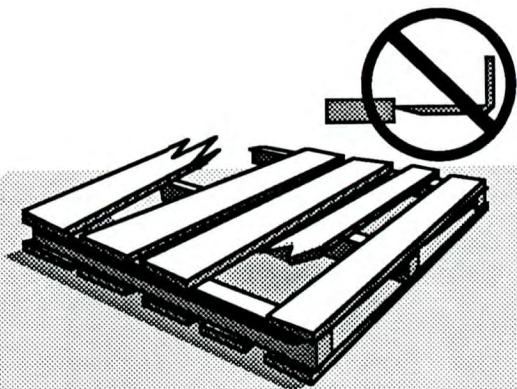

Do not move or store materials on damaged pallets or skids. Items can fall through them causing severe injury or death.

Make sure the pallet or skid you are using is in good condition and does not have defective or missing components and fasteners.

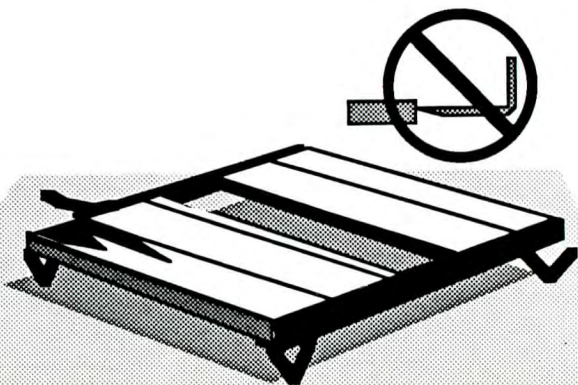

## Operating Hazards Loose Loads

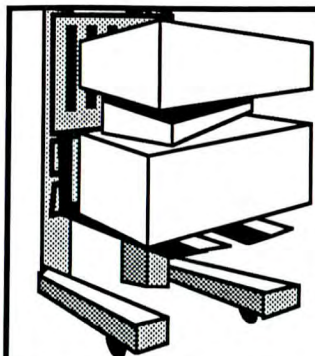

**!** **WARNING:**  
**Loose Loads**

Never carry loose  
or uneven material.



Spread the forks  
to fit the load.

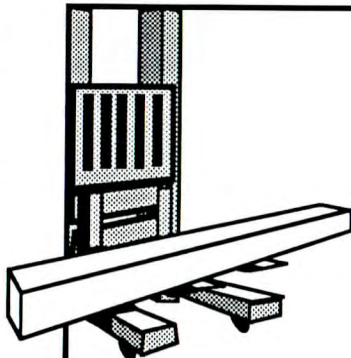

Center wide loads.

Stack and band  
loose material.

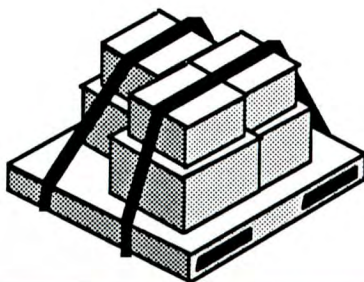

## Operating Hazards Long and Wide Loads

### **WARNING:** Long and Wide Loads

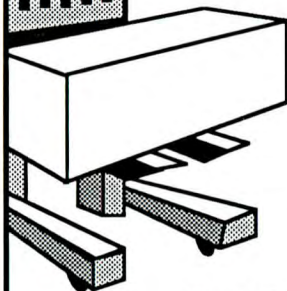

With long or wide loads you need more room---so---slow down and watch your clearance.

Keep wide loads low and watch your balance.  
Do not let the load rest on the outrigger.

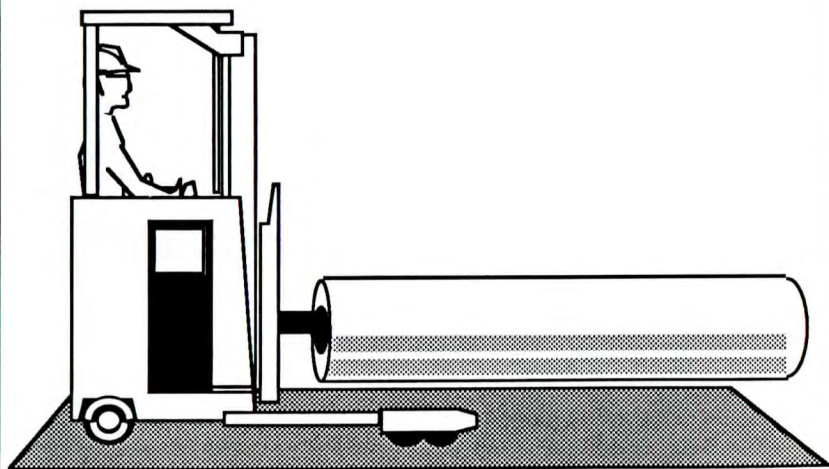

Remember, a long load will reduce the capacity of the truck.  
**KNOW AND UNDERSTAND YOUR TRUCK LOAD RATING.**

# Operating Hazards

## Chain Slack

 **WARNING:**  
Chain Slack

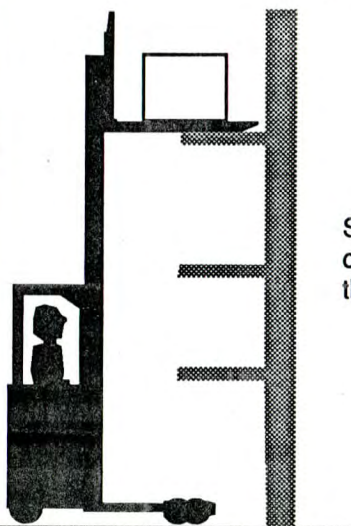

Slack chains mean rail or carriage hang-up. Raise the forks before you move.

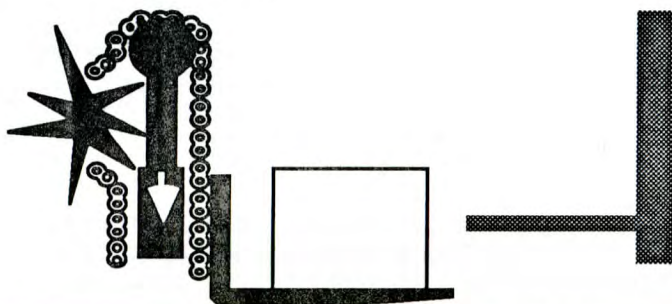
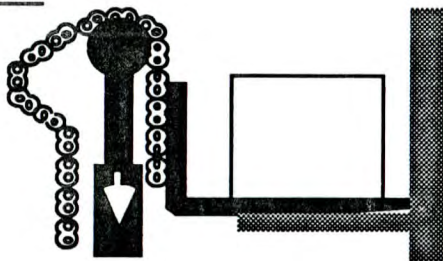



## Operating Hazards Right-Angle Stacking



**Warning: Right-angle stacking**

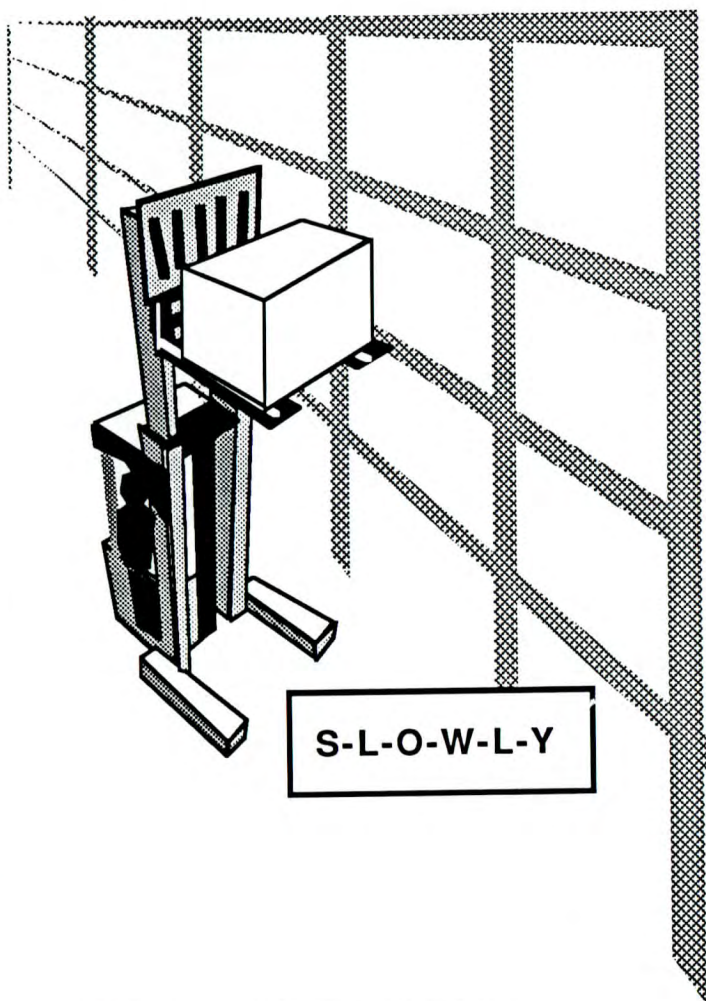

When right-angle stacking, or moving with a raised load to clear low objects, avoid sharp turns and move slowly.

## Operating Hazards Low Overhead Clearance



**WARNING: Low Overhead Clearance**

Watch overhead:  
moving into  
overhead struc-  
tures can tip a  
truck over.

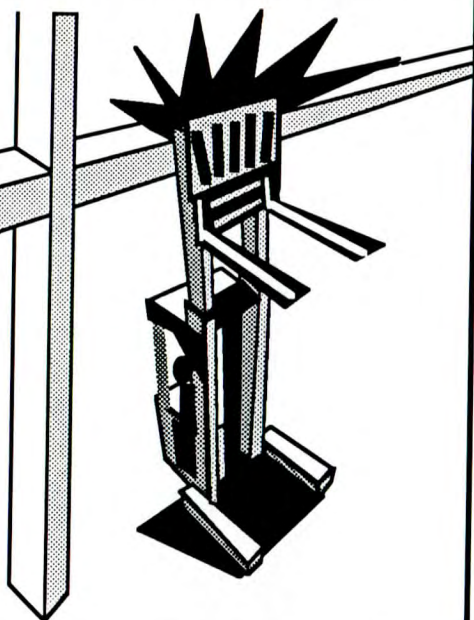

Know the height of your truck.  
Check your clearance.

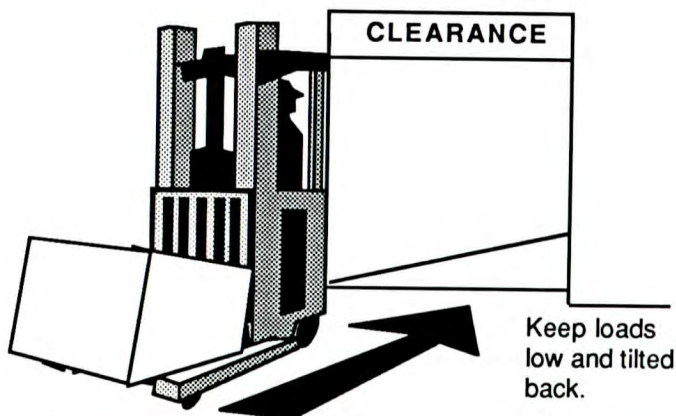

# Know Your Truck Chart

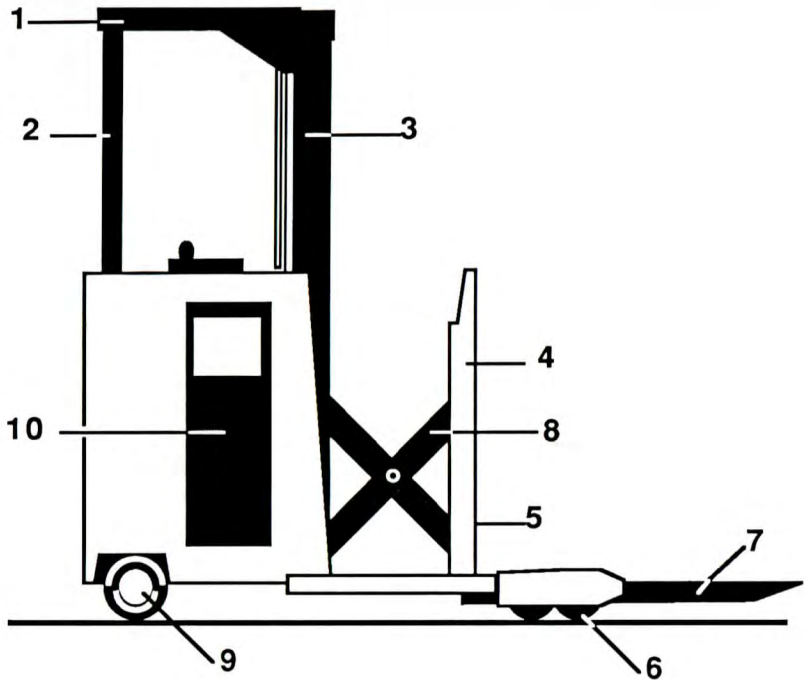

**NP/NS 300 Narrow Aisle Trucks**  
**(NP) = Pantograph**  
**(NS) = Straddle (no pantograph)**

1. Overhead guard
2. Overhead guard rear post
3. Upright assembly
4. Load backrest extension
5. Fork carriage
6. Load wheels (NP model shown)
7. Load forks
8. Pantograph mechanism (NP only)
9. Swivel caster
10. Battery compartment

## Know Your Truck

### Capacity, Components, and Features

MODEL	DESIGNATION/RATED LOAD CAPACITY
NP 20	2000 lbs @ 24 "(900kg @ 500mm)
NP & NS 30	3000 lbs @ 24" (1360kg @ 500mm)
NP & NS 40	4000 lbs @ 24" (1810kg @ 500mm)

#### BATTERIES

24 volt - 12 cell 15 plate  
24 volt - 12 cell 13 plate  
24 volt - 12 cell 11 plate  
24 volt - 12 cell 9 plate

Ranges from 23.2 to 11.5 kw.h  
at 6 hour rating

#### TRUCK COMPONENTS AND FEATURES

- removable lift off compartment door for improved access.
- removable hydraulic tank.
- component and hardware dimensions are combination USA inch and metric.
- polyurethane paint.
- 3 battery compartment lengths
- limited travel speed to 2-3 MPH when MFH is above the free lift with the triple stage upright, and when the carriage is elevated above the outer rail with the standard upright.
- hi-visibility overhead guard.
- return line hydraulic filter with spin-on replacement.
- multiple function hand control.
- battery disconnect.
- optimized ergonomically designed operator compartment.
- power assist steering
- rear post driver protection
- quiet drive train



## Know Your Truck Operator's Compartment

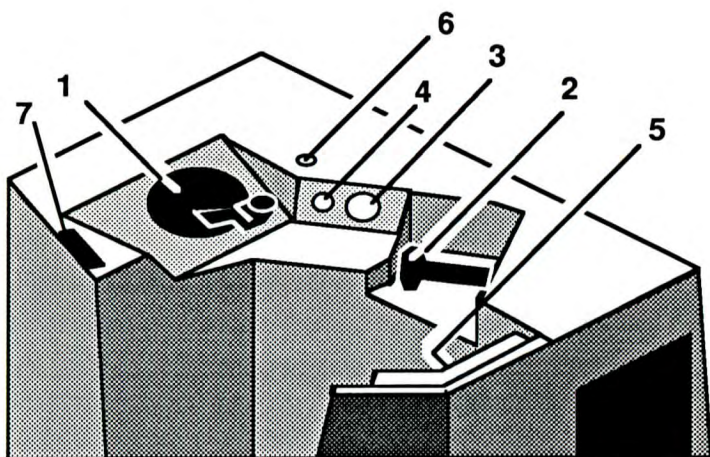

1. Steering handwheel.  
(tiller with spinner knob)
2. Multiple function control lever.  
This lever controls direction, speed, lift and lower, tilt and horn button on NP & NS trucks. This lever also controls reach on NP trucks only. Additional optional hydraulic control levers, if any, will be positioned to the left of this lever.
3. Battery charge indicator.
4. Key switch.
5. Hourmeter
6. Auxiliary function switch
7. Operator manual holder

**Familiarize  
yourself with the controls  
and follow  
safe operating rules**

# Know Your Truck

## Steering System - Control Handle

### POWER STEERING SYSTEM

The power steering motor drives a duplex pump which produces the fluid flow for steering and auxiliary functions.

The five inch steering tiller is equipped with a spinner knob.

### MULTIFUNCTION CONTROL HANDLE

direction and travel speed.

lift/lower.

tilt/pantograph/auxiliary functions.

A right hand multiple function control handle regulates direction, travel speed and plugging with a rotating motion--clockwise for forward, counterclockwise for reverse.

The "plugging" feature allows the operator to slow the truck and change direction at any speed without using the service brakes.

The lift and lower function is controlled by a push and pull motion---push to lower, pull to raise.

The tilt and reach function is controlled by pressing a button on the handle, and using the push/pull motion.

For the auxiliary functions, press a button on the cover and use the push/pull motion.

**NP TRUCKS:** When switching hydraulic functions, handle must be returned to the neutral (center) position for 1/10 second before another hydraulic function can be selected.

# Know Your Truck

## Brake System, Drive Axle and Electrical Components

### BRAKE SYSTEM

Drum and shoe spring applied mechanical release brakes. Armature shaft with braking force multiplied through drive unit gear reduction. The braking function is activated by allowing the brake pedal to rise. Power to the drive motor will be automatically turned off before the brake is fully applied. The power steer motor will remain on approximately eight seconds after brake is applied. To release the brake, place the left foot on the brake pedal and push to the floorboard; this will also activate a switch to turn on the power circuit to the drive motor.

### DRIVE AXLE

Vertical drive stationary motor with reduction drive unit mounted on ball bearings.

### ELECTRICAL COMPONENTS

Electric wiring - U.L. approved main harness and instrument harness.

Traction motor - series wound with class H insulation. Fan cooled and ventilated.

Ignition switch - on/off switch with removable key.

Horn button - on control handle for easy access.

Speed control - SCR controlled with bypass contactor.

Power steer/auxiliary motor - permanent magnet design with class H insulation.

Lift motor - series wound with class H insulation.

Relay board - contains relay interlock system for controlling lift, reach and tilt functions.

Electrically controlled solenoid valves that direct oil flow to the correct actuator.

Instruments - hourmeter, battery discharge indicator.

# Know Your Truck

## Filters, Uprights, and Options

### FILTER

- Hydraulic oil - 10 micron
- Sump breather - 40 micron

### UPRIGHTS

- Nested I-beam inner rail and outer rail channel with sealed rollers in upright, carriage and pantograph. Hydraulic piping is internal.

### OPTIONS - NP and NS

- Cold storage with heaters - in and out of 32 degree and below.
- Single function auxiliary and hose adaptation.
- U.L. type EE.
- Urethane drive tire.
- 10 inch load wheels.
- Outrigger ID's in 33 inches through 50 inches.

### OPTIONS - NP

- 37 inch carriage
- Sideshifter

### OPTIONS - NS

- 31 inch carriage
- Tilt carriage and hose adaptation



## Know Your Truck Nameplate

THIS IS THE LOCATION  
OF THE NAMEPLATE



The truck serial  
number is stamped  
in the frame here

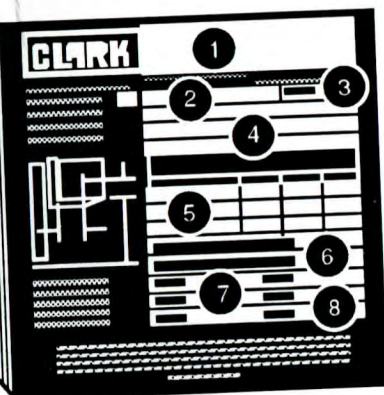



### KNOW THE DATA ON THE NAMEPLATE

1. Truck registered name.
2. Truck model number and serial number.
3. Type of construction. The code letter signifies the type of protection. Check with proper authority before entering areas where flammable or explosive material may be present.
4. Attachment description (if any)
5. Capacity, load center, and lifting height data.  
DO NOT EXCEED MAXIMUM SPECIFIED.
6. Truck weight less load.
7. Battery weight.
8. System voltage.

If the truck is modified, the capacity of the truck may be affected. Contact your authorized Clark dealer for a new nameplate showing the revised capacity.

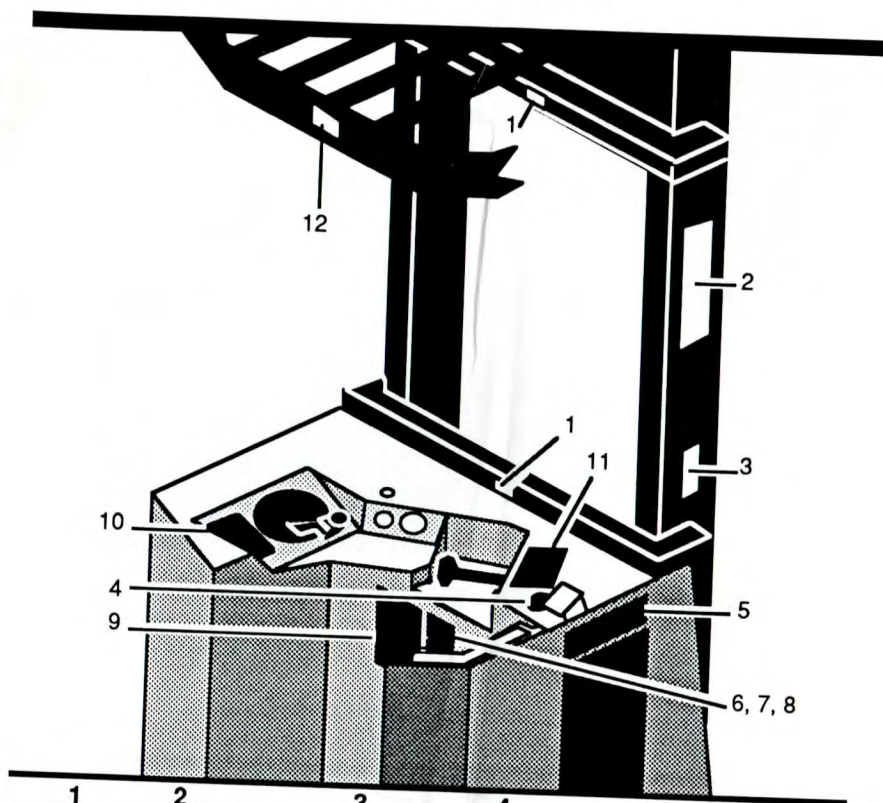
# Know Your Truck Truck Decal Locations



1  warning decal

2  White Logo

3  warning decal

4  Battery disconnect

5  Black Logo

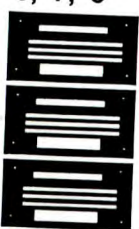
6, 7, 8  U.L. plates

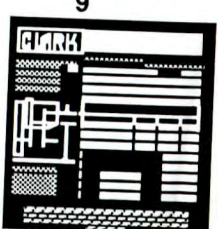
9  Nameplate

10  warning decal

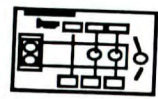
11  Hand control decal

12  D.O.G. plate

# Know Your Truck Safety Decals

---

## Warning Decal - Upright

This Decal warns of the danger of injury from movement between rails, chains, sheaves, fork carriage and other parts of the upright. Do not climb on or reach into the upright. Personal injury will result if any part of your body is placed between moving parts of the upright.



---

## Warning Decal - Keep Away From Forks

This Decal warns of the danger of injury from forks when they are in the raised position. Always make sure forks are in the locked position. Do not ride on or stand under the forks or attachment. The forks or attachment can fall and cause injury or death.

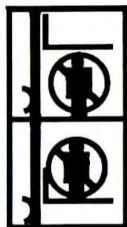

---

## Warning Decal - Operator Safety

This Plate describes basic instructions for the safe operation of this lift truck. Read and understand these instructions and the other safety messages in this manual.



---

## Plates - Underwriters Laboratories

This Plate designates that the truck is built to meet U.L. type classifications.



---

## Decal - Emergency Battery Disconnect

This Decal indicates the location of the emergency battery disconnect lever and the direction of lever movement.







## Before Operation

### Daily Inspection - Driver's Daily Checklist

**BE SURE THAT YOUR TRUCK IS SAFE TO OPERATE.**

Lift trucks should be inspected daily, or at the start of each shift. The following pages point out important areas to check during the daily inspection.

As an aid in carrying out this inspection, Clark has prepared a form called "Driver's Daily Checklist". Copies of this form may be obtained from your Clark dealer. We recommend that you use this form to make a daily record of your inspections and truck condition.



First, perform a visual inspection of the truck and its components. Walk around your lift truck and take note of obvious damage which may have been caused by operation during the last shift.



Check for leaks and loose fittings. Do NOT use bare hand. Oil may be hot or under pressure.



Check all of the critical components that handle or carry the load.



## Before Operation Daily Inspection - Wheels

---

Check the condition of the drive/steer wheel and tire. Remove objects that are embedded in the tread. Inspect the tires for excessive wear and breaks or "chunking out" and bond failure.

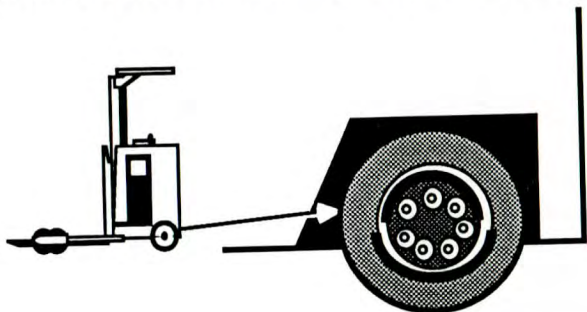

---

Check all wheel lug nuts to be sure none are missing.

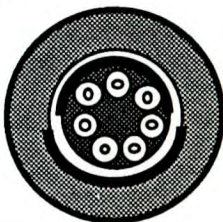

---

NP & NS 300 models are equipped with a spring loaded swivel caster wheel and tire. Look at the condition of the caster wheel, tire and springs and note it on your check list.

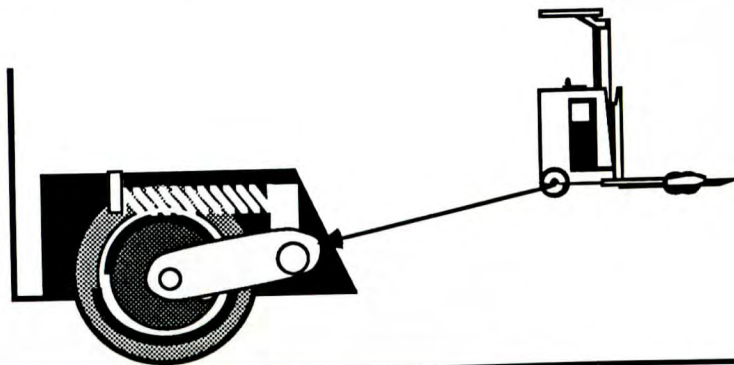

## Before Operation Daily Inspection - Visual

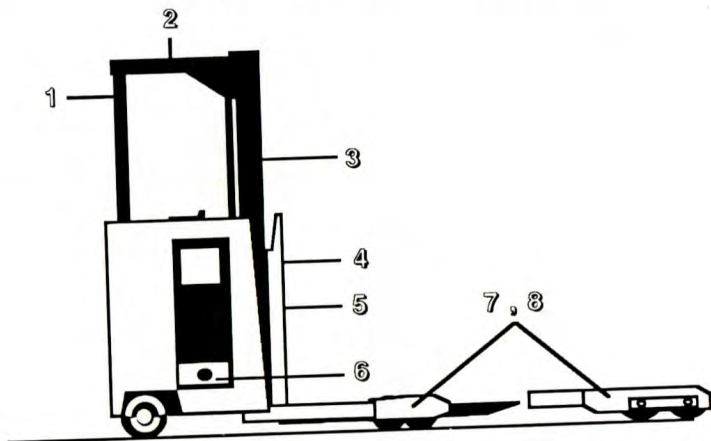

- 1 Check the rear post. Make sure it is correctly secured.
- 2 Check the condition of the overhead guard. Make sure it is correctly secured.
- 3 Visually check the condition of lift chains, hoses, electric cable, sheaves and retainers.
- 4 Check the pantograph plumbing for leaks, hose damage or interference.
- 5 Check the condition of the load backrest extension. Make sure it is correctly secured.
- 6 Check both battery retainers to make sure they are not damaged and are correctly positioned.

- 7 NP models are equipped with either one large load wheel and tire, two standard wheels, or two articulating wheels at the end of each outrigger. Check the condition of the load wheels and tires. Check for bond failure between wheel & tire, uneven wear, cracks and particle embedment.
- 8 NS models are equipped with two non-articulating load wheels at the end of each outrigger. Check the condition of these load wheels. Check for bond failure between wheel and tire, flat spots, uneven wear and particle embedment.

**NOTE THE CONDITION OF THESE ITEMS ON YOUR CHECK LIST.**



## Before Operation Daily Inspection - forks

Inspect the lift forks for cracks, breaks, bending and wear. The fork surfaces should be level and even with each other. The height difference between both fork tips should be no more than (6 mm) 0.25 inch maximum. If the fork blade at the heel of the fork is worn down by more than 10 percent, the load capacity of the forks is reduced and they must be replaced.

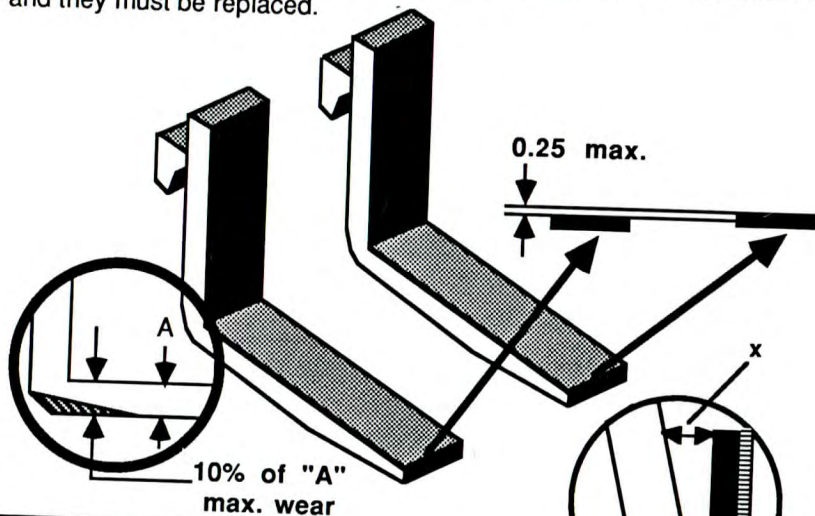

Inspect the forks for twists and bends. Put a 2"x4"x24" metal block on the blade of the fork with the 4" surface against the blade. Put a carpenter's square on the top of the block and against the shank. Check the fork 18" above the blade to make sure it is not bent more than specified in the chart.

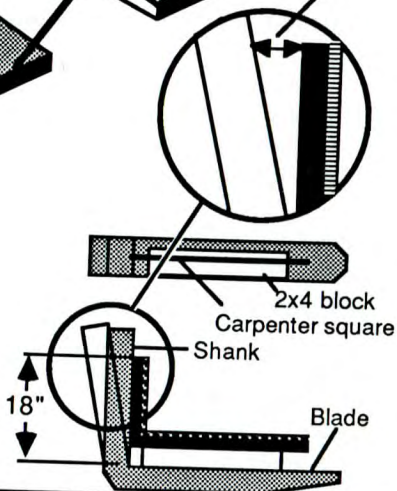

Fork cross - section	Allowable "x" values for various blade lengths			
	42" blade	48" blade	54" blade	60" blade
1-1/2 x 4	15/16	1-1/4	1-9/16	1-15/16
1-3/4 x 5	1/2	5/8	25/32	31/32

To prevent accidental shifting of the forks inspect the fork latches. Make sure they are not damaged or broken and they operate freely and lock correctly.





## Before Operation

### Daily Inspection - Battery, Connector, Key Switch, and Horn.

Look at the battery connector to make sure that it has been properly connected and is not damaged. Be sure Emergency Battery Disconnect is working correctly.

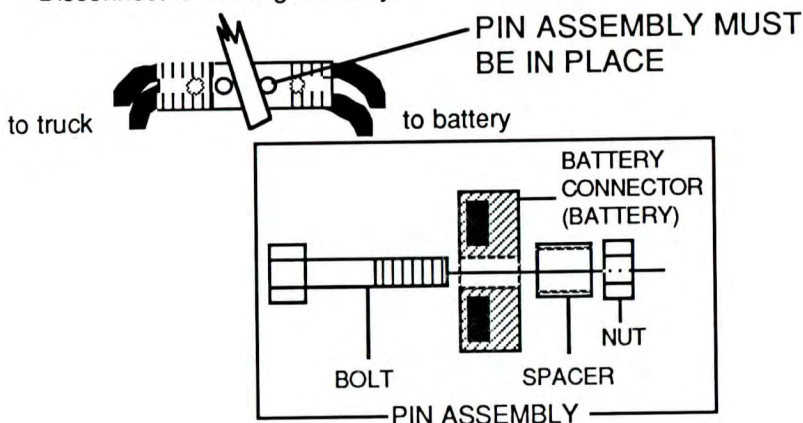

Enter the operator's compartment. Insert the key into the switch and turn clockwise to the "on" position. Then place your left foot on the brake pedal and push down to floor board level. This will energize the electrical control circuit and start the power steering motor and at the same time complete the power circuit to the pump and drive motor.



Press horn button to make sure that the horn functions correctly. If horn does not function, report it immediately to the designated authority, and do not operate the truck.

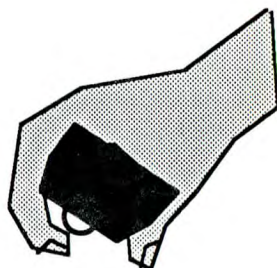

## Before Operation Daily Inspection - Instruments

Check hourmeter to insure that it is not damaged and is functioning properly. Report any malfunction or damage to the proper authority. Write the hourmeter reading on your daily check list.



Check battery charge indicator for damage. Needle should remain in green area. Check this meter frequently during operation. Report any damage or malfunction immediately.

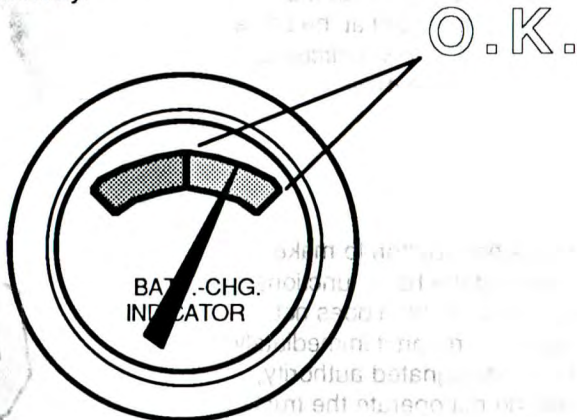

## Before Operation Daily Inspection - Tilt

If your truck has a tilting carriage, check forward and back tilt (be sure you have adequate unobstructed clearance). Tilt the forks all the way back, then all the way forward. Observe tilt and report any erratic or unusual operation, such as binding, squeeling or chatter.

### TO TILT FORKS BACK

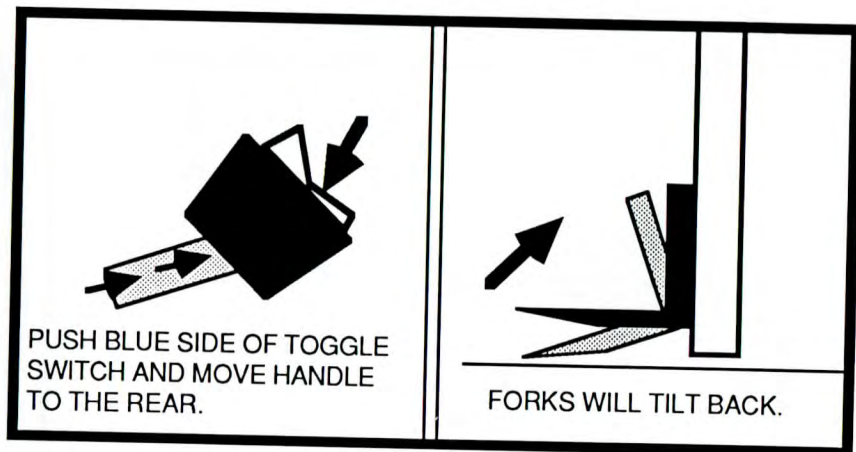

### TO TILT FORWARD

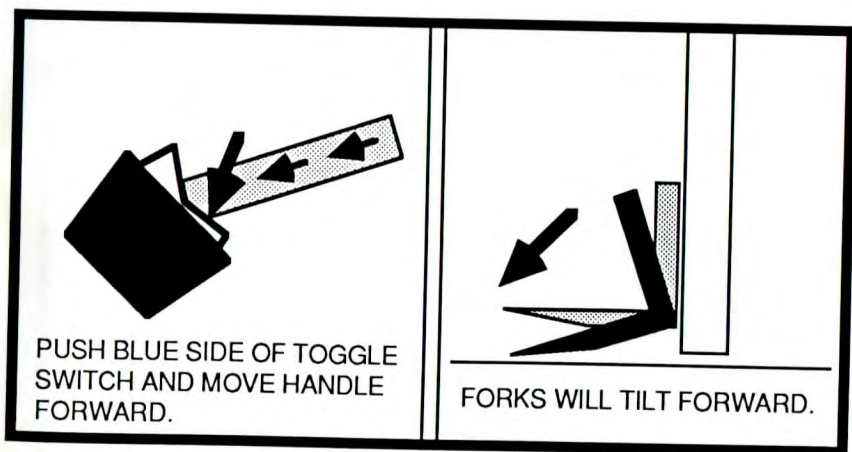

## Before Operation

### Daily Inspection - Lift and Lower

Check upright lift and lower (be sure you have adequate unobstructed overhead clearance).

Raise carriage to its full lift position, then lower carriage fully. Watch lift and lower cycle, report any erratic or unusual operation such as binding, squeeling or chatter. Look for excessive wear of components.

### TO RAISE FORKS

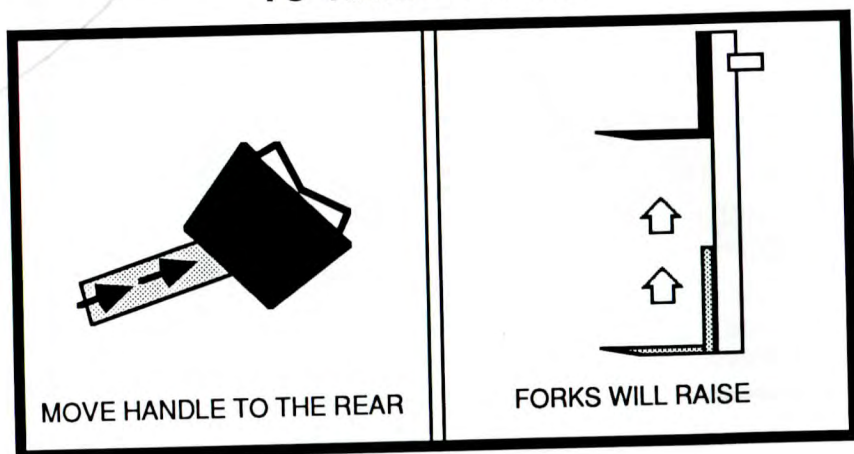

### TO LOWER FORKS

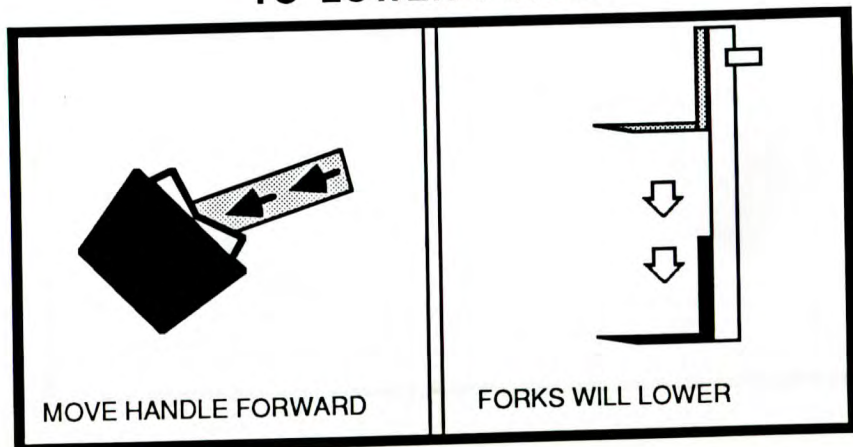



# Before Operation

## Daily Inspection - Pantograph

### NP ONLY

Check pantograph reach and return (be sure you have adequate forward clearance).

Extend pantograph to full forward reach, then return pantograph all the way back. Observe pantograph reach and return. The pantograph should operate smoothly and quietly. The face of the forks should extend beyond the outrigger when fully extended. Report any erratic or unusual operation.

### TO EXTEND PANTOGRAPH

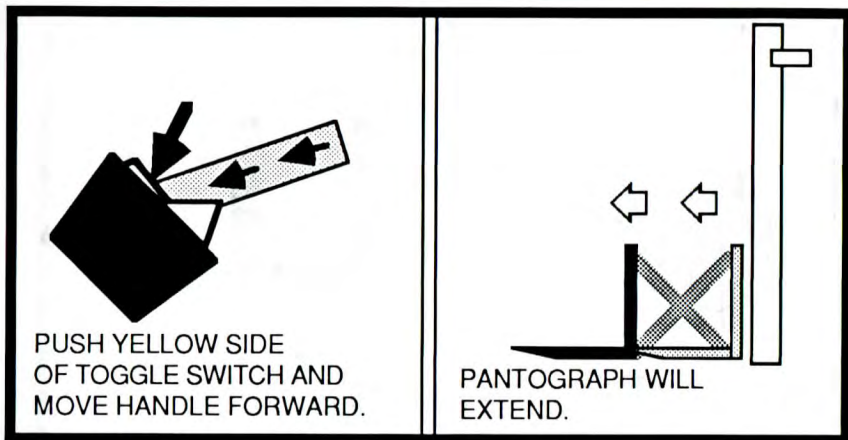

### TO RETRACT PANTOGRAPH

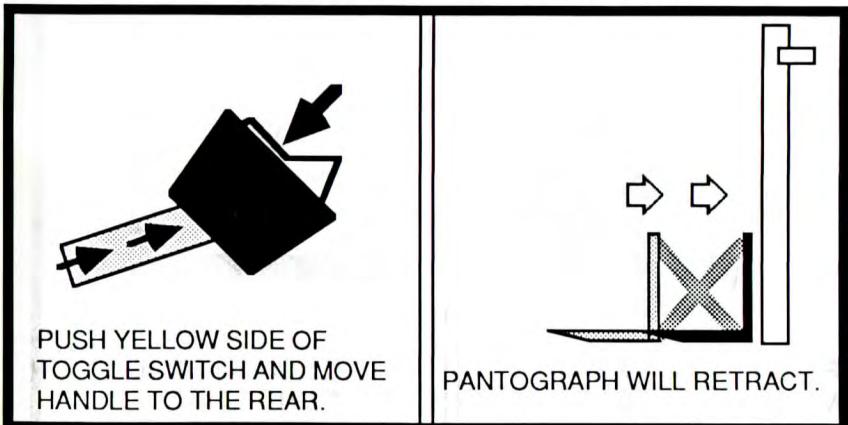

## Before Operation Daily Inspection - Side Shift

Check side shift function if your truck is so equipped (be sure you have adequate clearance).

Move side shifter through one complete cycle. Observe the side shifter through the cycle and report any erratic or unusual operation such as binding, squeeling or chatter during movement. Look for excessive wear on components.

### TO SIDE SHIFT LEFT

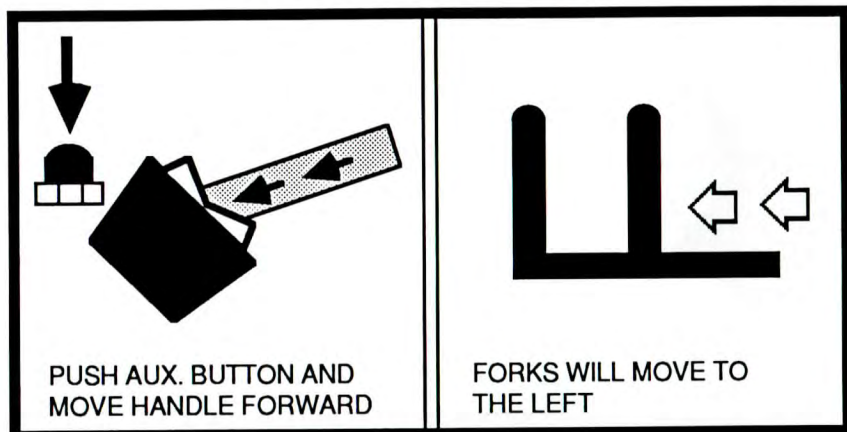

### TO SIDE SHIFT RIGHT

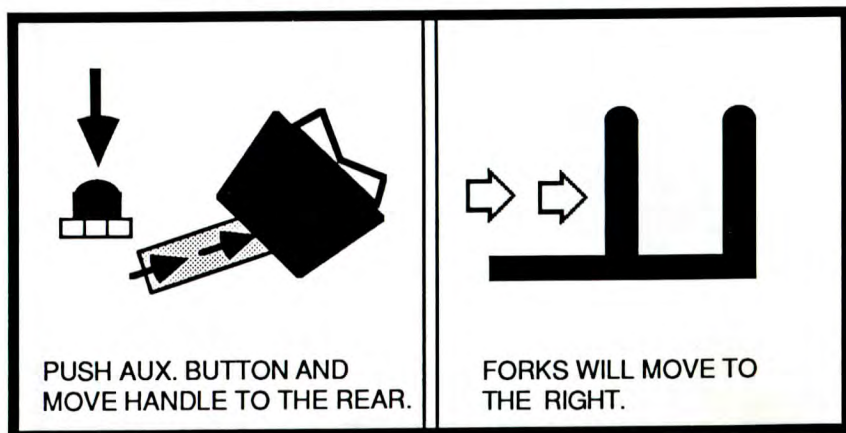

## Before Operation

### Daily Inspection - Forward And Reverse Travel

Check the steering by rotating the steer wheel to full left and full right turn. Report any erratic or unusual performance.

Check forward and reverse travel (make sure there are no obstructions in your line of travel).

Raise forks 4 to 6 inches from the floor and tilt them all the way back.

Move truck forward. After several feet raise your left foot from the brake pedal and truck will stop. Move the truck in reverse. After several feet stop truck by raising your left foot from the brake pedal. Report any erratic or unusual operation such as noise, or uneven stopping motion.

#### TO MOVE TRUCK FORWARD

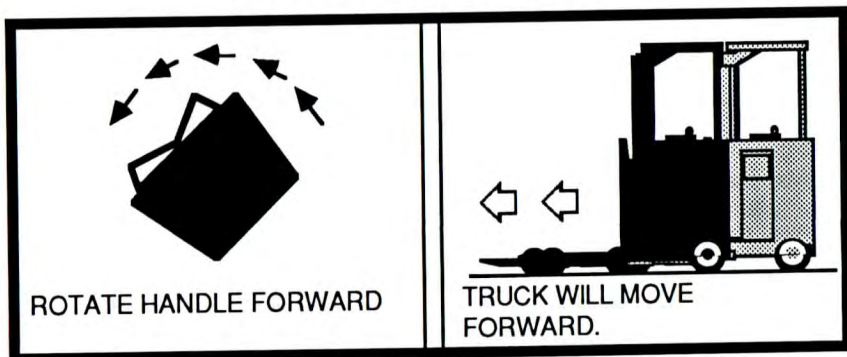

#### TO MOVE TRUCK REARWARD

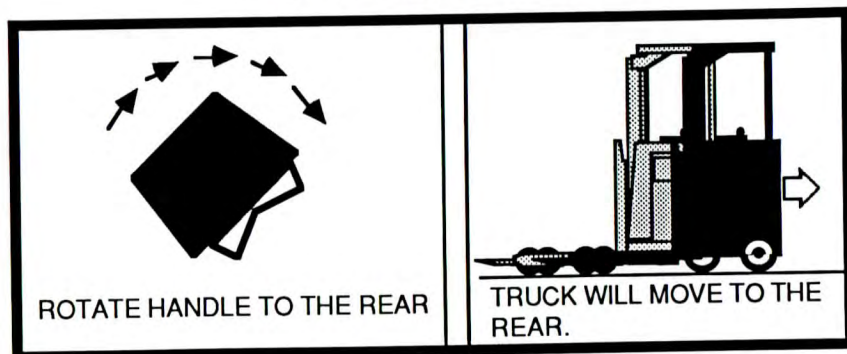

## Before Operation

### Daily Inspection - Plugging and Cutout Switch

Check the forward and reverse plugging (make sure there are no obstructions in your line of travel). Drive the truck forward at a slow speed and very quickly rotate the control handle to reverse at creep position. The truck should slow to a smooth stop, and accelerate slowly in reverse. Drive the truck in reverse at a slow speed and very quickly rotate the control handle to forward at creep position. The truck should slow to a smooth stop, and accelerate slowly forward.

If plugging control is as specified, then repeat the procedure at high speed. Report any erratic or unusual operation.

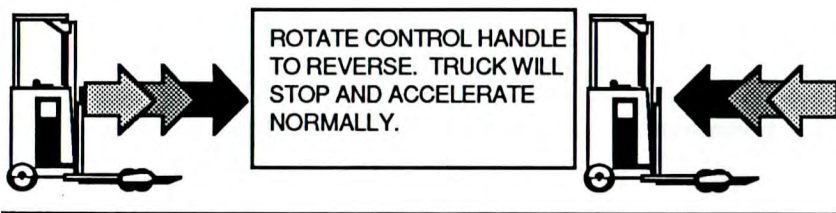

Check the high-speed cutout switch (be sure you have adequate overhead clearance and that no obstructions are in your line of travel). With no load, travel full speed forward while raising forks. Travel speed will be reduced to one half when forks reach cutout height.

Observe truck speed and fork height through the cycle and report any erratic or unusual operation.

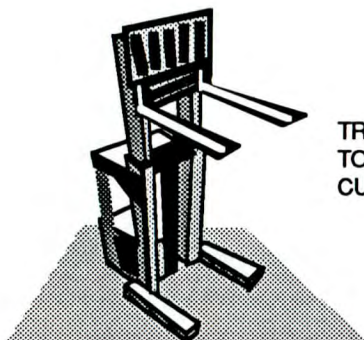

TRUCK SPEED WILL REDUCE TO HALF WHEN FORKS REACH CUTOUT HEIGHT.



## Before Operation Daily Inspection - Review

Lower the forks to the floor. If your truck is equipped with tilt lower the fork tips to the floor. If your truck is equipped with a pantograph retract it all the way.

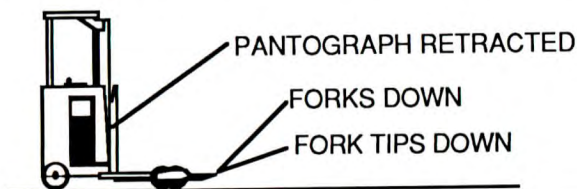

---

Turn the key counterclockwise to "OFF" position, remove the key and carefully dismount from the truck.



---

Review operator's daily check list to make certain that it has been properly marked, and turn it in to the designated authority.



---

If all of the "Before Operation" checks are normal or satisfactory, the truck can be used.

**DO NOT OPERATE A LIFT TRUCK THAT HAS A MAINTENANCE PROBLEM, OR IS NOT SAFE TO OPERATE. Remove the key and put an "OUT OF SERVICE" tag on the truck.**



## Operation Before You Start

Be sure that you read and understand the information in the Operator's Manual before operating the lift truck. The Operator's Manual is stored in a holder.



---

Before operating a lift truck, each operator must check his truck and complete the "DRIVER'S DAILY CHECKLIST". Please refer to the section "BEFORE OPERATION" for information on "HOW TO PERFORM THE DAILY INSPECTION".



---

Remember, before starting and operating a lift truck it is good practice to always start from a safe condition. Check to see that:

- \* Brake is applied
- \* Forks are fully lowered  
(to slightly above floor level)
- \* You are familiar with all the control functions
- \* All controls are in neutral
- \* Truck has been checked and is ready to operate

## Operation Traveling Empty

Carefully enter operator's compartment.  
Remember that pressing down on the brake pedal will release the brake, and this should be avoided until you are ready to move the truck (in case truck is on a slight incline).



Smoothly and gently pull back on "tilt" control (if your truck is so equipped) to raise fork tips from the floor slightly.

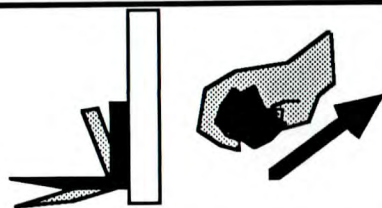

Gently pull on multiple function hand control. Raise forks four to six inches above the floor.

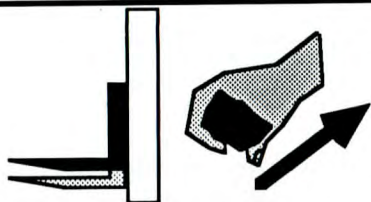

Check all around the truck to make sure that the path of travel is unobstructed.

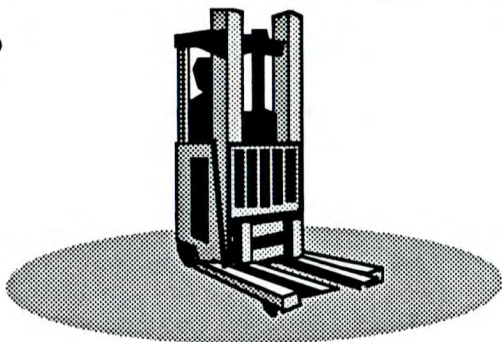

**BE FAMILIAR WITH "GENERAL SAFETY RULES" SECTION.**



## Operation Picking Up a Load

**LOAD MUST NOT EXCEED RATED CAPACITY OF TRUCK  
AT LOAD CENTER.**

---

Load should be centered and  
forks should be near outside  
edges of the load.

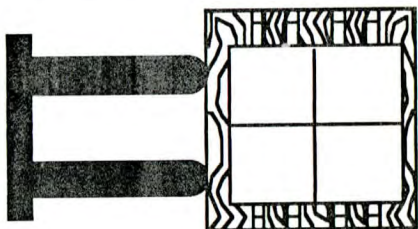

If necessary, adjust the forks by  
lifting the fork lock lever and  
spread the forks as far as possible  
to the desired position.

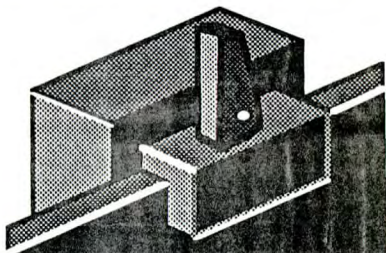

Lower the lever to lock the  
forks securely into the notch  
in the fork bar.

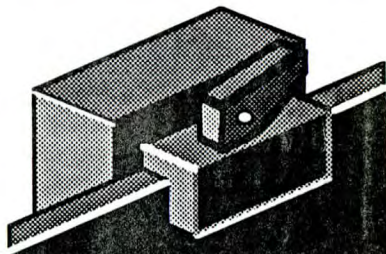

Raise load four to six inches  
from floor...retract pantograph.

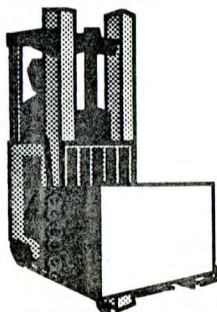

## Operation Traveling Loaded

If your truck has optional tilt, the carriage should be tilted back to cradle the load when traveling.

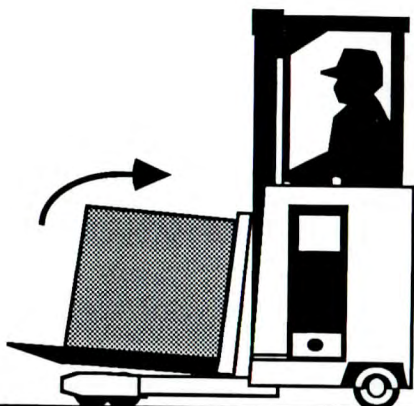

Do not change direction at a high rate of speed. Load can fall from forks.

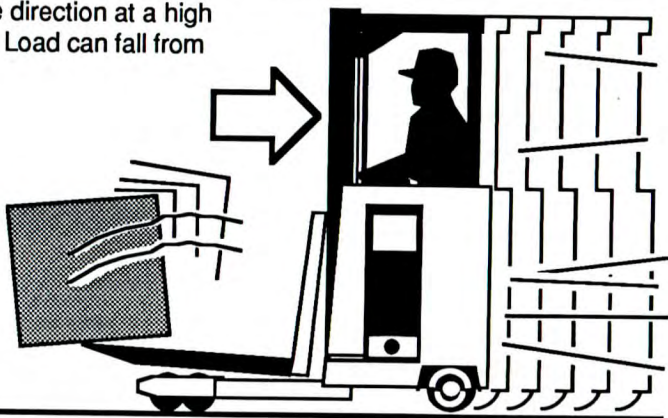

If the load blocks your view travel in reverse.

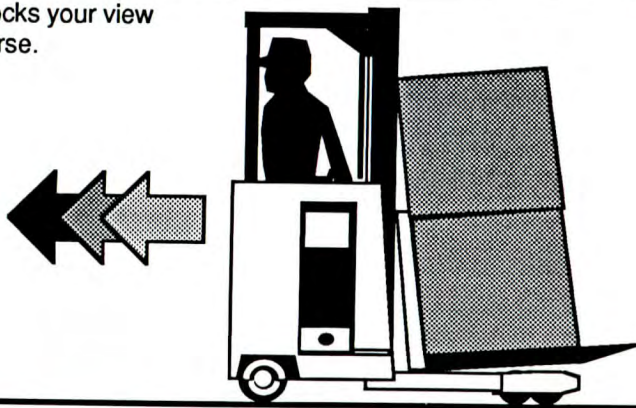

## Operation Right Angle Stacking - NP

Drive the truck parallel to the rack system at the desired location. Raise the load slightly above the desired height and tilt to level position.

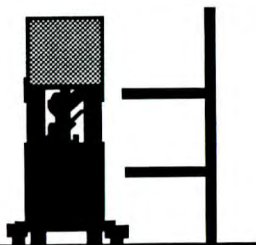

Turn toward the rack (right angle stack) and continue to travel slowly until the load is in the desired location and the truck is at right angle to the rack system. Position the truck so the ends of outriggers are close (about two inches) from the rack system.



Use "Reach" to extend the load into position. Make sure the load is supported by both beams with a minimum of two inch overhang. Lower forks until load is fully supported by the rack system.

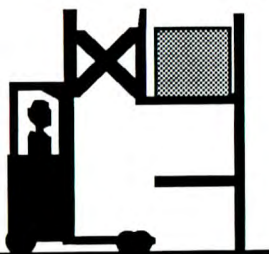

Retract pantograph fully. Return the truck to a position parallel to the rack system. Lower the forks to travel position.

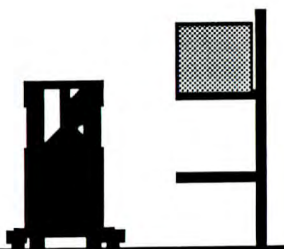

Use minimum forward and reverse tilt when stacking and unstacking loads. Never tilt a load forward unless it is over a rack or at a low lift height.

## Operation Right Angle Stacking - NS

Drive the truck parallel to the rack system at the desired location.  
Raise the load slightly above the desired height and tilt to level position.

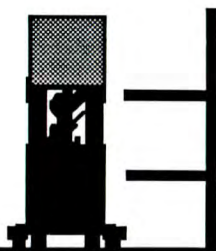

Turn toward the rack (right angle stack) and continue to travel slowly until the load is in the desired location and the truck is at right angle to the rack system. Position the truck so the outriggers are in line with the openings between loads (floor loads) or load is aligned with opening.

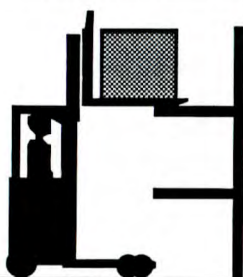

Drive truck forward into the rack system.  
Make sure the load is supported by both beams with a minimum of two inch overhang. Lower the forks until the load is fully supported by the rack system.



Drive truck backwards out of rack system. Return truck to position parallel to rack system.  
Lower forks to travel position.

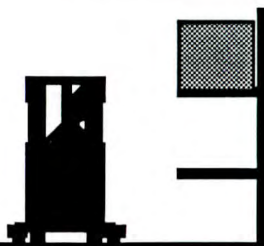

Use minimum forward and reverse tilt when stacking and unstacking loads. Never tilt a load forward unless it is over a rack or at a low lift height.



# Operation Parking

Park lift trucks in designated parking areas only. Do not obstruct traffic lanes or aisles.

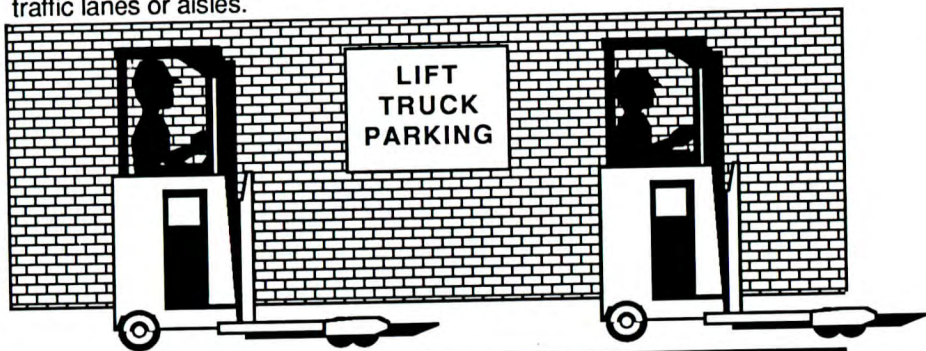

Lower the forks to the floor. If your truck is equipped with tilt lower the fork tips to the floor. If your truck is equipped with a pantograph retract it all the way.

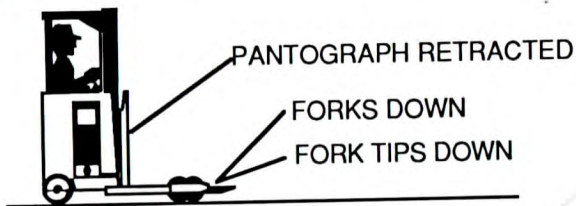

Turn the key counterclockwise to "OFF" position, remove the key.



Carefully dismount from truck.

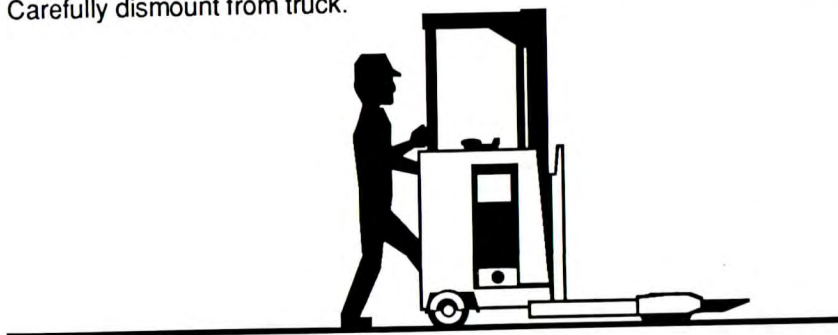

(



## Emergency Towing

Driver must be in truck with the brake pedal fully depressed, key on and power steer pump running.

Truck of sufficient capacity to pull NP/NS truck

Hook chain (of sufficient capacity to pull truck) around upright mounting trunnions.



Hook chain to tow pin

Truck of sufficient capacity to lift NP/NS truck

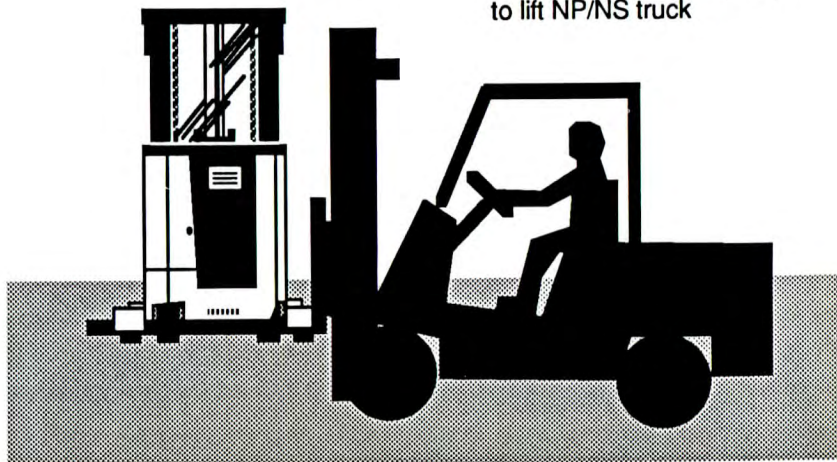





# Planned Maintenance

## General

Regular maintenance and care of your lift truck is essential for economy and utilization reasons, but most important for your safety. An improperly maintained lift truck is a potential source of danger to the operator, and to other personnel working near it. Lift trucks should be inspected daily, or at the start of each shift. This daily inspection should include a visual check for leaks and any obvious damage which may have been caused by operation during the last shift. Check the tires and wheel bolts. Check the upright and lift chains. Check the forks and load backrest extension. Look for loose bolts and fittings. Make sure that the overhead guard is in good condition. Check all controls. Make sure that all systems are functioning correctly. Check the hydraulic sump oil level. Make sure that all instruments, warning lights and the horn are operating correctly and that your truck is safe to operate. Use the daily inspection sheet as a check list and record of your findings.

In addition, Clark recommends that you set up and follow a planned maintenance and inspection program. Performed on a regular basis, the program will provide the opportunity to make thorough inspections and checks on the safe operating condition of your lift truck. Necessary adjustments and repairs are made as needed. The schedule for these planned maintenance (PM) inspections will depend on the conditions of your particular application and lift truck use. Recommended periodic inspection and maintenance items are listed in the Maintenance and Lubrication section. Also shown is the PM inspection and report form which may be obtained from your local Clark dealer. He is also prepared to help you with your Planned Maintenance and Inspection Program if you want assistance. He has specially trained service personnel who are authorized to check your lift truck according to the respective safety regulations.

Also, in the Maintenance and Lubrication section, you will find a listing of useful specifications for lubricants, critical bolt torques, refill capacities and settings for your truck.

If you have the need for more information on the care and repair of your truck, see your Clark dealer.

## Planned Maintenance Intervals

### Recommended Planned Maintenance Intervals

**Insure  
operational  
safety**

#### Operating conditions

Time intervals between maintenance is largely determined by operating conditions. For example, operation in sandy, dusty locations requires shorter maintenance intervals than operation in clean warehouses. The indicated intervals are intended for normal operation. To allow for a better understanding of this aspect, following is further clarification:

##### NORMAL OPERATION:

Basically, eight-hour material handling.

##### SEVERE OPERATION:

Prolonged operating hours or constant usage.

##### EXTREME OPERATION:

1. In sandy or dusty locations, i.e. cement plant, lumber or flour mills, coal dust or stone crushing sites.
2. High-temperature locations, i.e. steel mills, foundries, etc.
3. Sudden temperature changes (constant trips from buildings into the open air), e.g. refrigeration plant.

If your lift truck is used in extreme operating conditions, you must shorten the maintenance intervals accordingly.

## Planned Maintenance Battery Removal



### WARNING

#### SULFURIC ACID

THE BATTERY CONTAINS CORROSIVE ACID WHICH CAN CAUSE INJURY. IF ACID CONTACTS YOUR EYES OR SKIN, FLUSH IMMEDIATELY WITH WATER AND GET MEDICAL ASSISTANCE.

Position the truck in the designated area, turn off key switch, set the parking brake and disconnect the battery. The battery can be removed from either side of the truck. Lift and rotate battery retainers to remove.

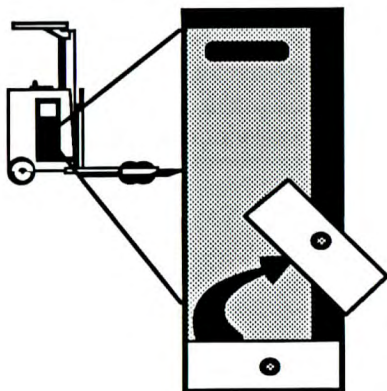

A recommended method of handling the battery is to use a platform equipped with rollers...similar to the one shown. If the battery to be handled is uncovered...cover the battery with a non-conducting material.

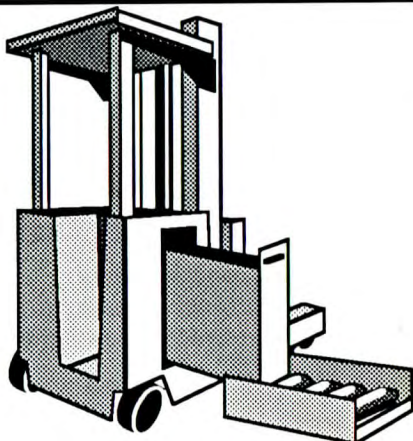



## Planned Maintenance Handling Battery

Change or service batteries only in an area designated for this purpose

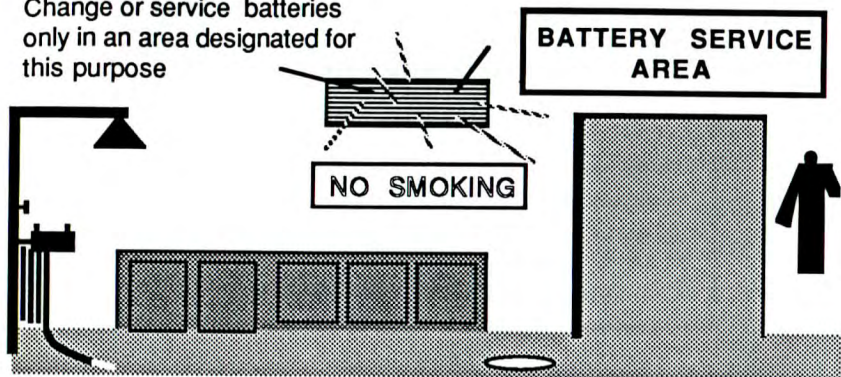

Be sure this area has provisions, to flush and neutralize spillage, to ventilate fumes from gassing batteries and provisions for fire protection.

Before attempting to change or charge a battery, the truck shall be positioned in the designated battery service area and the brake applied so the truck cannot move.

Be sure the area is equipped with material handling equipment designed for the purpose of removing and replacing batteries such as a conveyer or overhead hoist equipped with safety hooks.

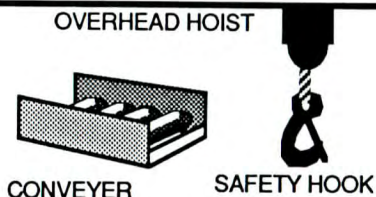

When using an overhead hoist, be sure an insulated spreader bar or similar lifting device is used so the lifting force is vertical.

To avoid side forces from damaging the battery, the distance between the chains must be the same as the distance between the battery lifting eyes. Make sure the lifting hooks are the correct size to fit the lifting eyes of the battery.

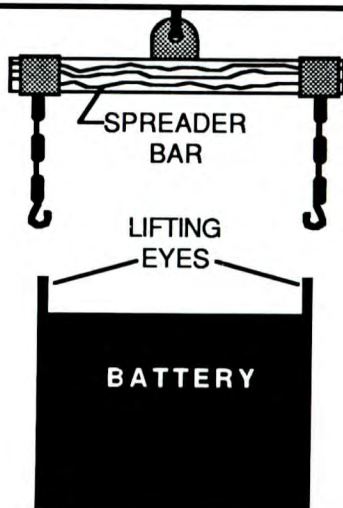



## Planned Maintenance Handling Battery

If the battery does not have a cover of its own, cover the battery with a non-conductive material (sheet of plywood) prior to attaching a battery lifting device.

NON-CONDUCTIVE  
MATERIAL

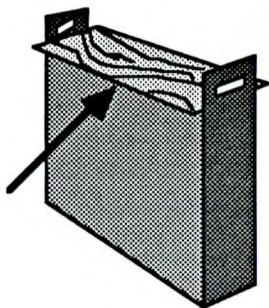

When using a power hoist, be sure the hoist is equipped with a chain container to accumulate the excess lifting chain.

CHAIN CONTAINER

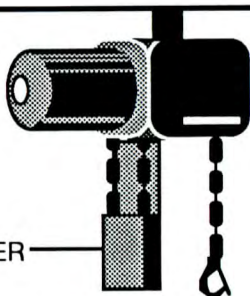

Keep all tools and other metallic objects away from the terminals

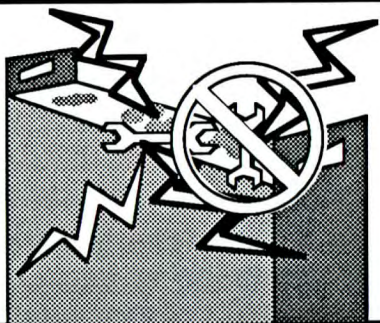

Persons maintaining storage batteries must wear protective clothing such as face shield, long sleeves and gauntlet gloves.



## Planned Maintenance Handling Battery

Hydrogen emissions from charging batteries are flammable. No smoking shall be allowed in the charging area. Do not check the electrolyte level with an open flame. Do not allow open flame, sparks or electric arcs in battery charging area.



When charging batteries, the vent caps must be kept in place to avoid electrolyte spray. Care must be taken to assure that vent caps are functioning. The vent cap holes must be open to allow the battery to breathe. The battery, or battery compartment cover(s) must be open to dissipate heat.

VENT CAP HOLE

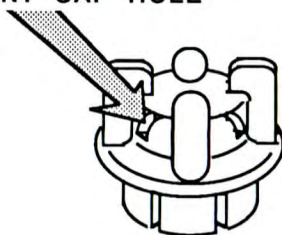

### **IMPORTANT:**

**If batteries discharge rapidly during normal operation or do not charge to the correct specifications, contact a qualified battery service technician to check the battery for you. DO NOT ADD ELECTROLYTE OR ATTEMPT TO SERVICE THE BATTERY.**

## Planned Maintenance Battery Cleaning

⚠

### WARNING

### BATTERY SERVICE

**BATTERY SERVICE MUST BE  
DONE BY TRAINED PERSONNEL.  
BATTERY ACID CAN CAUSE  
SEVERE BURNS AND INJURY.**

---

Once the battery is out of the truck...a lifting device equipped with an insulated spread bar and safety hooks can be used to transport this style battery.



---

The easiest and most satisfactory method of cleaning a battery is to wash it occasionally with a low pressure cold water spray. The top can also be washed off with a solution of baking soda (add a box of baking soda to a pail of water and stir until dissolved) and rinsed with clear water. It is wise to have this solution around a battery room at all times. Be sure all vent caps are tightly in place during cleaning operation.

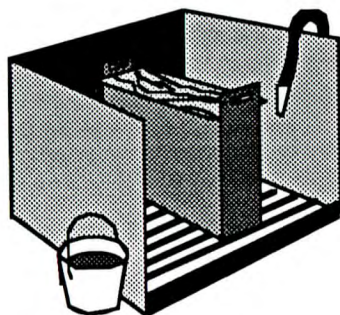

## Planned Maintenance

### Battery Life, Records, and Installation

#### BATTERY MAINTENANCE:

Refer to the battery vendor for their recommended procedures.

#### KEEPING BATTERY RECORDS:

Some type of records shall be kept to get the best service out of your battery and truck. Select a pilot cell, take readings of specific gravity and temperature before and after charging, and record with the date. It is best to change the pilot cell occasionally to distribute any electrolyte loss over the battery in taking the readings. Every two to three months, take complete battery readings ... check specific gravity, temperature and voltage ... and record them.

#### HOW TO GET MAXIMUM LIFE FROM THE BATTERY:

**DO NOT ADD ACID TO A BATTERY.** Only a qualified battery representative should determine if this is necessary.

Lift only with a carefully constructed lifting device which will not put pressure on the battery tray.

Battery shall be checked before each charge for electrolyte level. Add water before charge, but do not overfill. Overfilling causes loss of electrolyte. The level should be slightly below the lower lip of the filling vent hole.

Keep battery clean and dry, Wash down as needed.

Do not overcharge

Keep battery records as indicated above.

Keep metal objects and tools away from top of battery to prevent short circuits.

Keep open flames away from top of battery to prevent explosions.

#### INSTALL BATTERY:

Install the battery in the truck (as explained previously) and secure it.



# Lubrication Standard

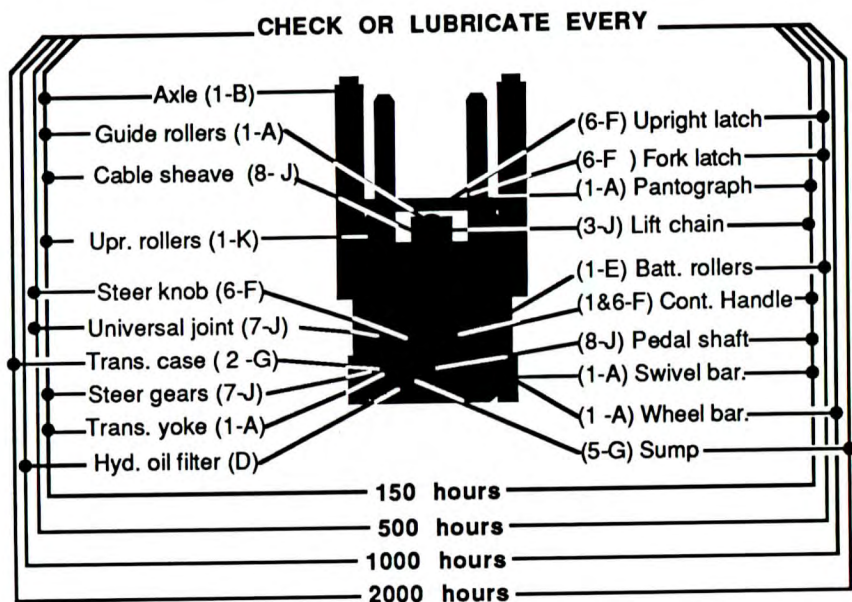

## Lubricants

- |   |                              |
|---|------------------------------|
| (1) - MP1- multipurpose grease NLG1 # 1   | (6) - SAE 20 Engine oil      |
| (2) - GL5 - transmission lubricant AP1GL5 | (7) - 886785 Spray lubricant |
| (3) - CL - chain lubricant Clark 886399   | (8) - Dry graphite           |
| (5) - MS68 Hydraulic oil                  |                              |

## Method

- |  |                                |
|--|--------------------------------|
| (A) - Use standard lube gun                            | (F) - Apply light film         |
| (B) - Use lube gun and adaptor for flush type fittings | (G) - Drain, flush and refill  |
| (C) - Clean in solvent and re-oil                      | (H) - Repack bearing           |
| (D) - Change filter                                    | (J) - Clean and lubricate      |
| (E) - Remove, clean and repack                         | (K) - Apply to channel of rail |

# Lubrication Location Chart

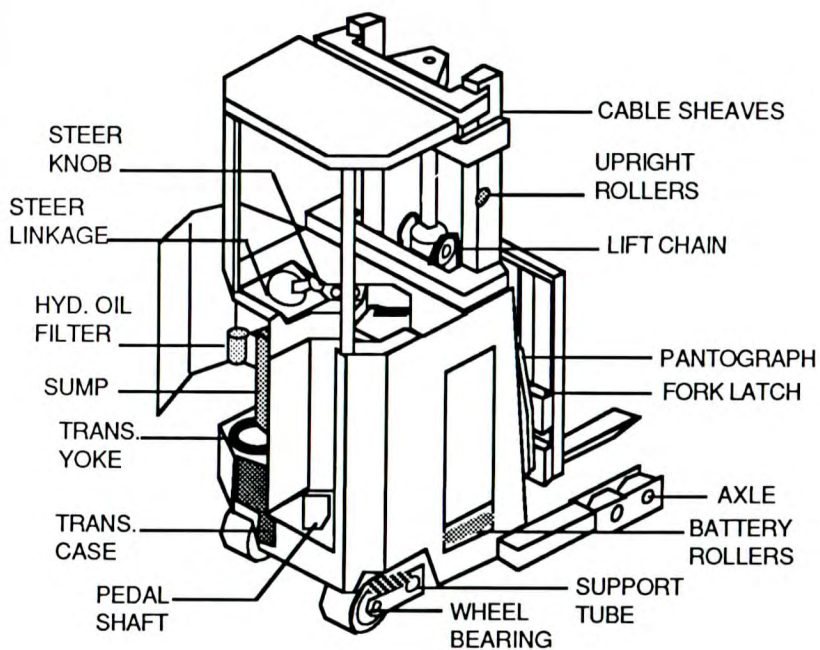

# Lubrication Cold Storage

**CHECK OR LUBRICATE EVERY**

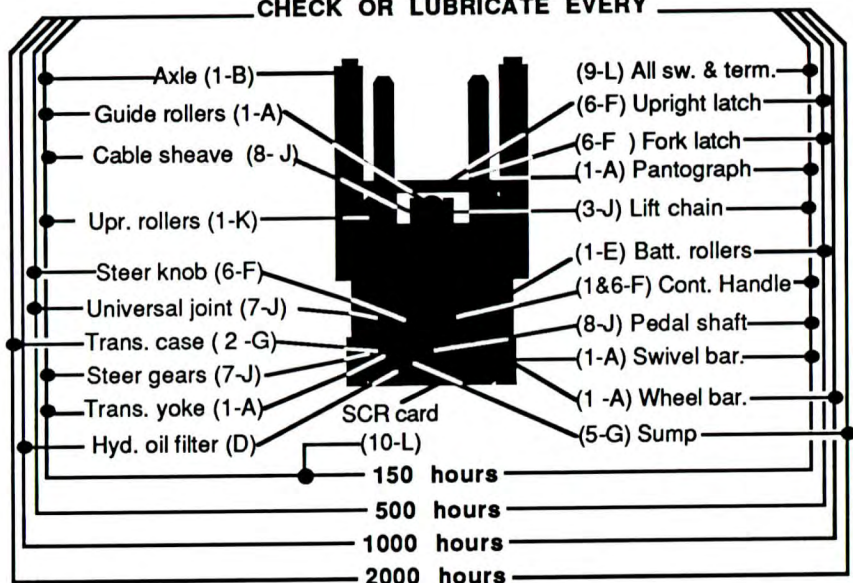

## Lubricants

- |  |                                 |  |
|--|---------------------------------|--|
| (1) - MIL-G-23827A<br>Low temp. grease     | (5) - MS226<br>Aircraft fluid   | (8) - Dry graphite                       |
| (2) - Transmission fluid<br>Dexron II      | (6) - SAE 20<br>Engine oil      | (9) - Clark 886784<br>Protective Spray   |
| (3) - CL - chain lubricant<br>Clark 886399 | (7) - 886785<br>Spray lubricant | (10) - Clark 1801145<br>Protective Spray |

## Method

- |   |                                |
|---|--------------------------------|
| (A) - Use standard lube gun                               | (F) - Apply light film         |
| (B) - Use lube gun and adaptor<br>for flush type fittings | (G) - Drain, flush and refill  |
| (C) - Clean in solvent and re-oil                         | (H) - Repack bearing           |
| (D) - Change filter                                       | (J) - Clean and lubricate      |
| (E) - Remove, clean and repack                            | (K) - Apply to channel of rail |
|   | (L) - Spray                    |





## Troubleshooting

Symptom	Possible Cause	Remedies
No tilt (motor does not run)	Valve switch misadjusted or defective.	Adjust or replace valve switch.
	Valve not operating.	Check linkage.
	Control wiring open (pump contactor does not energize).	See Service Reference (PM - 538)
	Power wiring open (pump contactor does not energize).	See Service Reference (PM - 538)
Noisy pump caused by cavitation	Oil supply low.	Fill reservoir.
	Oil too heavy.	Change to proper viscosity.
	Oil filter plugged.	Clean filters.
	Suction line plugged or too small.	Clean line and check for size.
	Oil supply low.	Fill reservoir.
Oil heating	Contaminated oil.	Drain reservoir-fill with clean oil.
	Setting of relief valve too high or too low.	Set to correct pressure
	Oil in system is too light.	Drain reservoir-fill with correct viscosity oil.
	Worn shaft seal.	Replace shaft seal.
Shaft seal leakage	Broken diaphragm seal or back-up gasket.	if replacing shaft seal does not stop leakage
	Bearings out of position.	disassemble and check gasket and seal for proper fit.
	Excessive internal wear.	Fill reservoir.
	Low oil level.	Tighten fittings.
	Air leaking into suction line.	Drain reservoir. Fill with non foaming oil.
Foaming oil	Wrong kind of oil.	Clean orifices in tilt cylinder.
	Orifices plugged. Damaged rod.	Replace.
Slow or erratic tilt	Defective hose.	Tighten.
	Loose fittings.	
Hydraulic system leaks oil		

# Troubleshooting

Symptom	Possible Cause	Remedies
Lift or tilt cyl. leaking.	Seal damaged	Replace
Transmission leaks oil.	Rod or gland damaged	Inspect and replace
Steers hard.	Defective seal or housing	Replace
	U-joint bearing tight	Check bearing
	Linkage is binding	Lubricate
	Low steer pressure	Check relief setting
	Drive unit bearings worn or tight	Check bearings
	Corroded	Remove, clean, and lubricate
Battery rollers bind.	Improper adjustment	See service manual
Too much or not enough brake.	Worn brake linings	Inspect and replace
No operation.	Truck does not run, key on brake switch closed	Check battery and connector condition
	Bad control fuse	Replace fuse
	Bad power fuse	Replace fuse
	Open circuit	Repair
	Open circuit	Repair
	PMT tripped	Turn key off & on
	Battery discharged or defective	Charge and inspect
	Loose connection(power wiring)	Tighten connections
	Defective motor	Inspect and repair
	Brakes dragging	Adjust
	Load wheel binding	Check clearance
	Defective SCR control	SCR missadjusted or failed component

## Troubleshooting

Symptom	Possible Cause	Remedies
No lift (motor runs) direction control OK	Excessive load	Check load, lifting capacity of truck
	Possible low oil supply causing airlock	Add oil and bleed hydraulic cylinder
	Plugged suction screen	Clean the screen - flush and refill reservoir
	Low pressure	Check relief valve pressure
	Pump defective	Check oil pressure
No lift (motor does not run) direction control OK	Valve switch misadjusted or defective	Adjust or replace valve switch
	Valve not operating	Check linkage
	Control wiring open to pump contactor	Check wiring
	Defective motor	Repair motor
	Battery discharged	Charge battery
Slow lift	Excessive load	Check truck capacity, reduce load
	Air in hydraulic system	Bleed hydraulic cylinder
	Leak in lift cylinder	Check oil flow
	Plugged suction screen	Clean the screen - flush and refill reservoir
	Worn pump/motor unit	Check oil press., volume (rebuild or replace)
No lower	Control valve linkage broken	Inspect and repair
	Mechanical binding	Inspect mast
	Flow valve on mast defective	Replace
Lower excessively slow	Flow valve on mast defective	Replace valve
No tilt (motor runs)	Excessive load	Check load
	Plugged orifice	Inspect orifice in tilt cylinder
	Valve not operating	Check valve

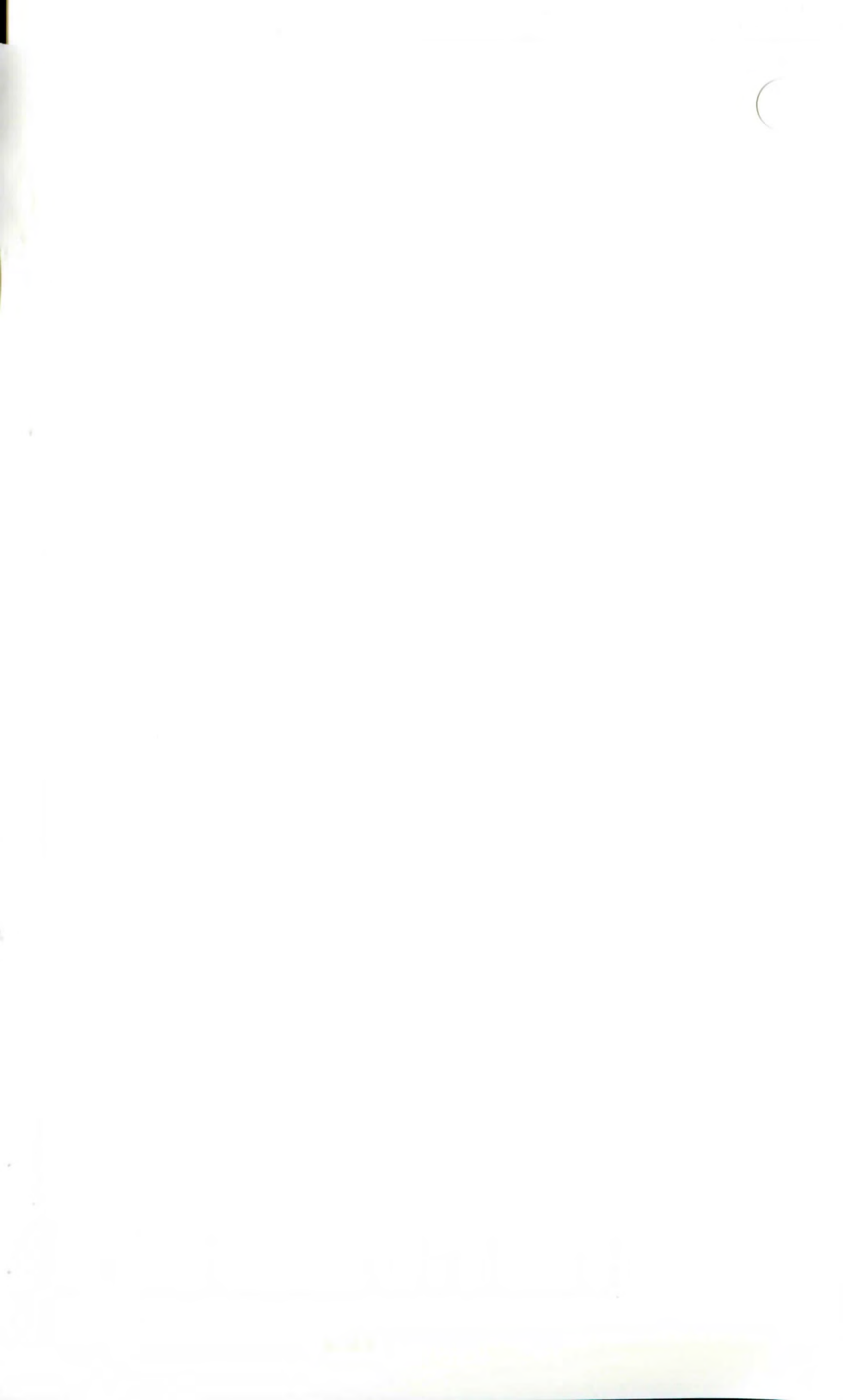



# NP 300 Electrical Schematic

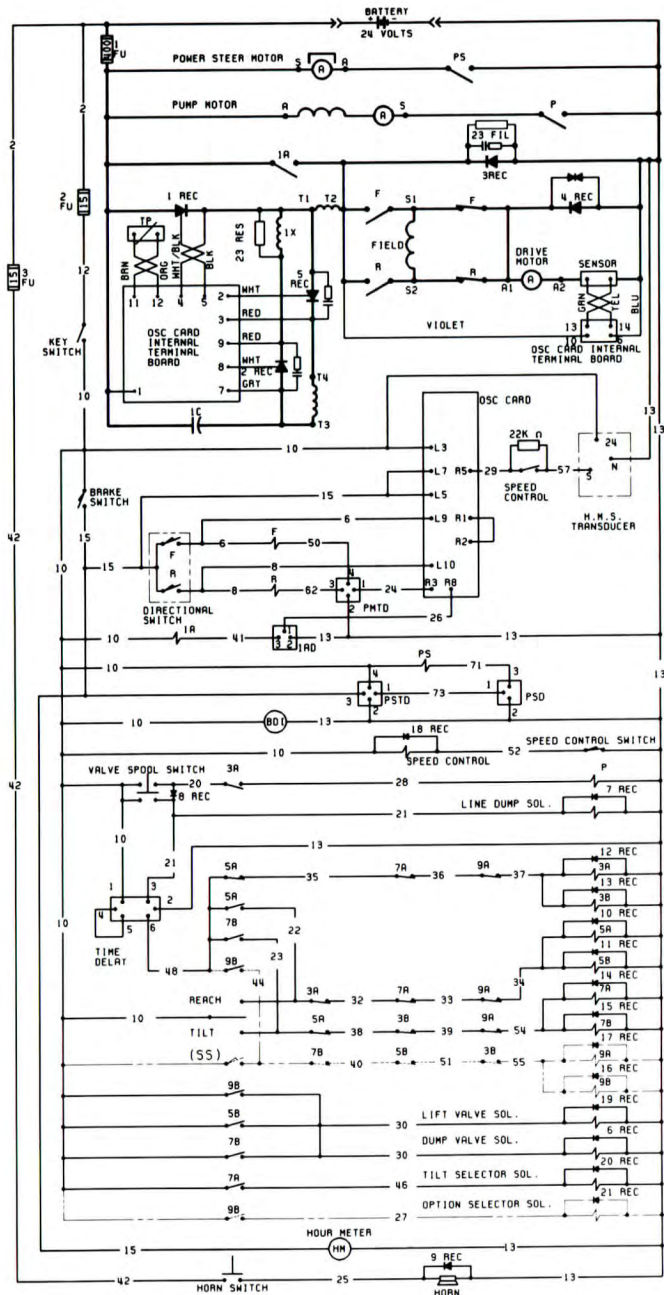

# NP 300 Hydraulic Schematic

CIRCUIT FOR SIDE SHIFT OPTION

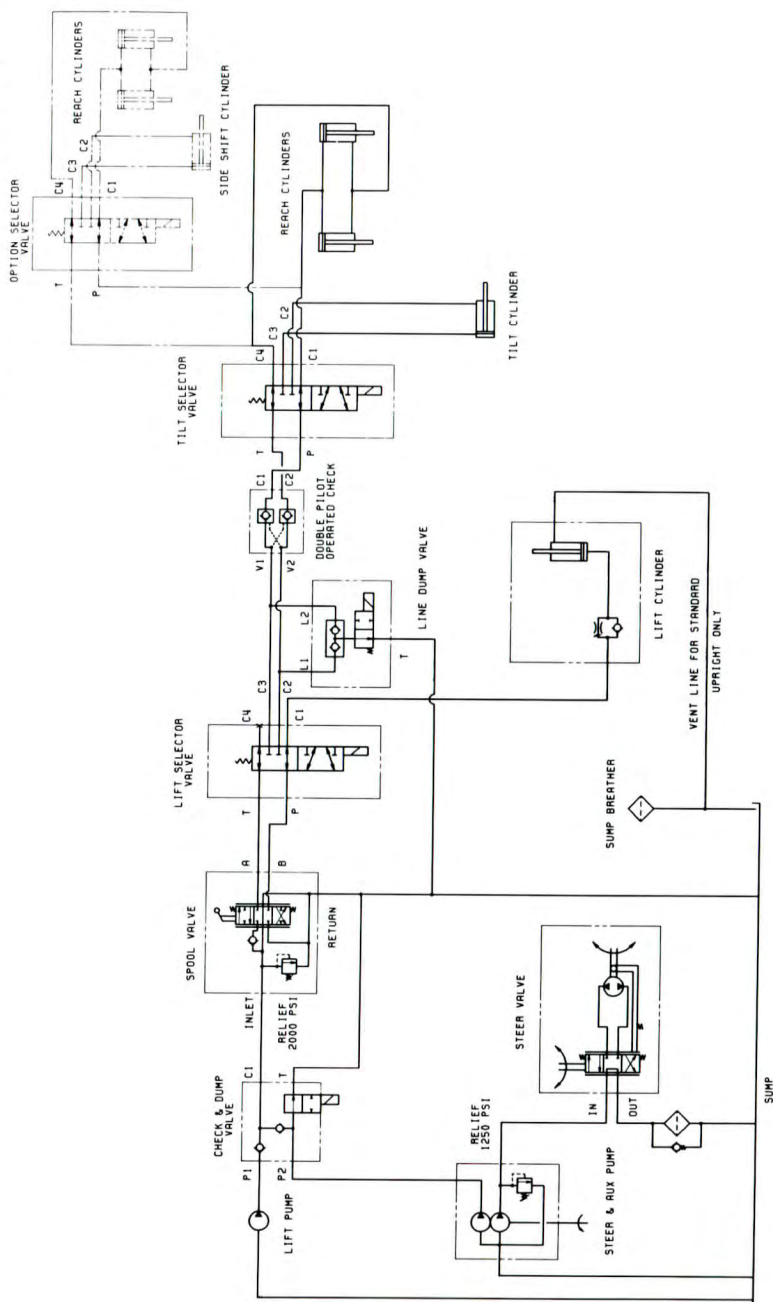

# NS 300 Electrical Schematic

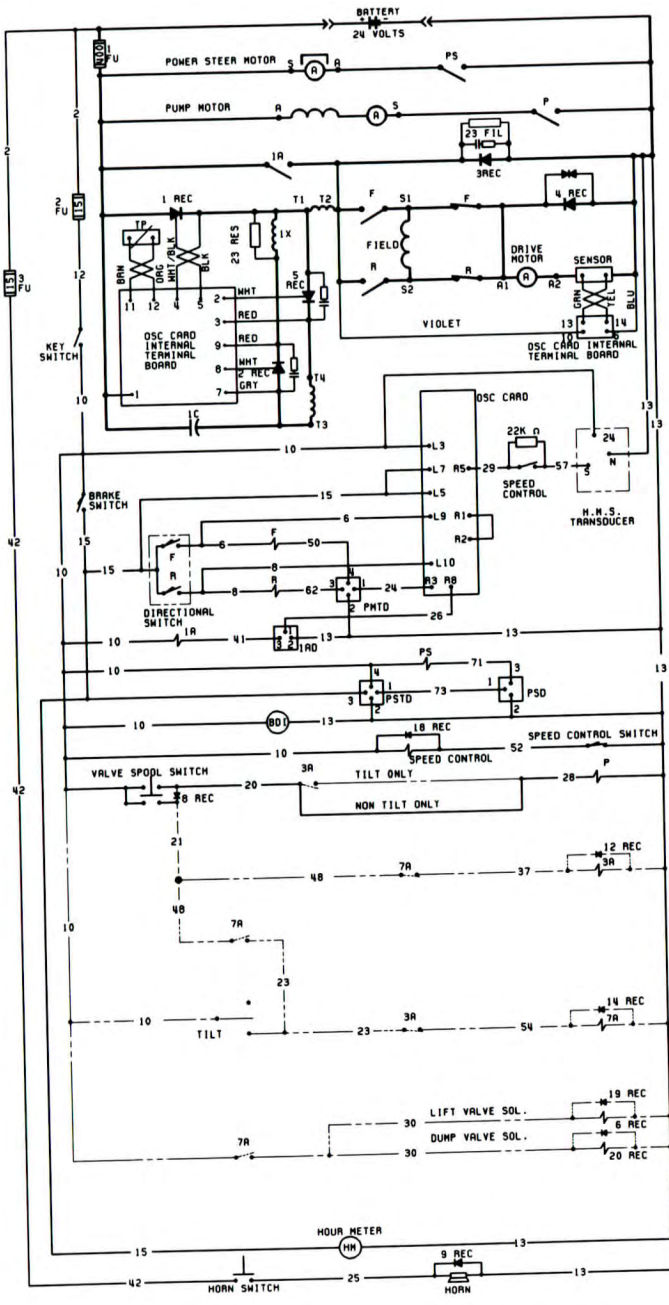

# NS 300 Hydraulic Schematic

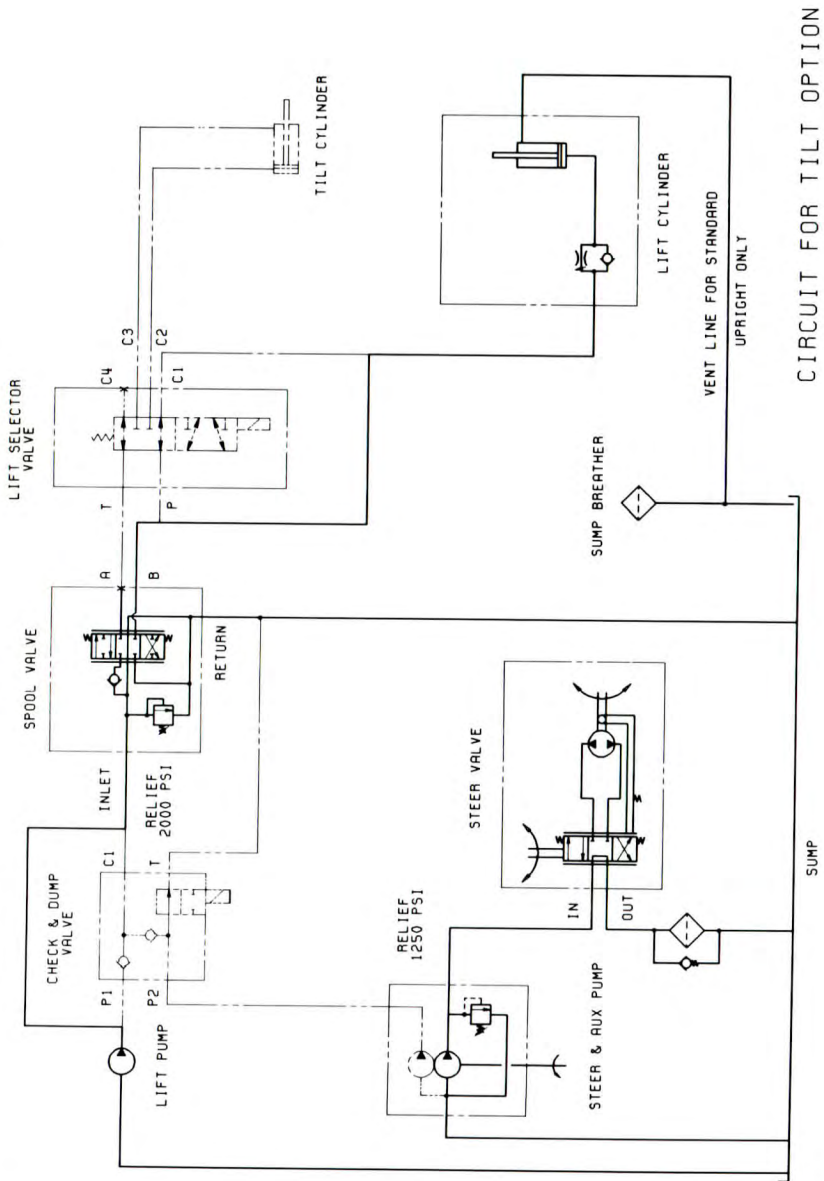

CIRCUIT FOR TILT OPTION



## For Handy Reference

Record the following information  
pertaining to your truck:

Model No. \_\_\_\_\_

Serial No. \_\_\_\_\_

Attachment \_\_\_\_\_

Total Weight - Empty \_\_\_\_\_

Truck Rated Capacity \_\_\_\_\_

Gross Truck Weight (w/ Rated Load) \_\_\_\_\_

Customer Truck Identification No. \_\_\_\_\_







Additional copies of this manual may be purchased from  
YOUR AUTHORIZED CLARK DEALER

---

---

# **CLARK** Material Systems Technology Company

A business unit of Clark Equipment Company

Asheville, NC 28776  
Battle Creek, MI 49016  
Georgetown, KY 40324  
St. Thomas, Ontario, Canada N5P 1H2

Printed in U.S.A.